

Room linear robot – for three dimensional applications

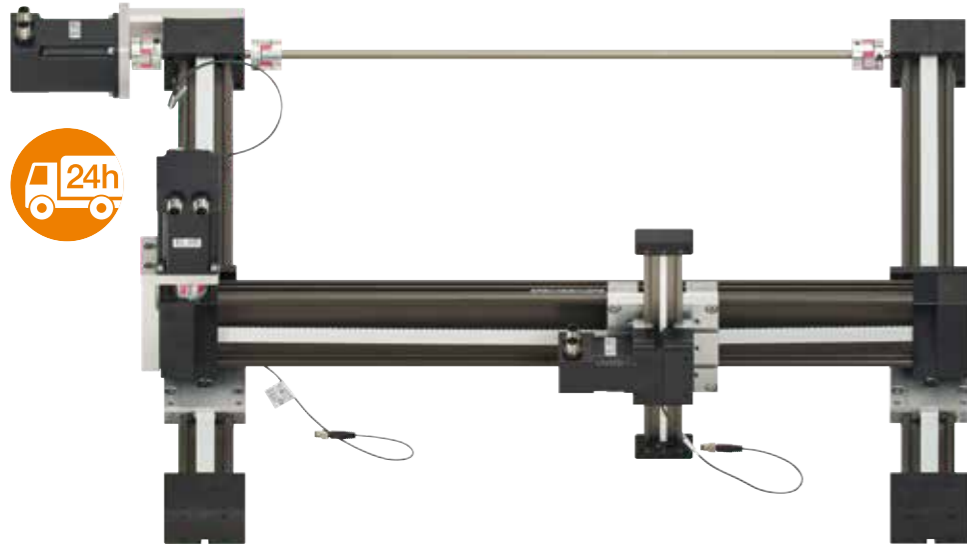

DLE-RG-0001

- **x-axis:** drylin® ZLW-1040 toothed belt axis with NEMA23 stepper motor with encoder
- **y-axis:** drylin® ZLW-1080 toothed belt axis with NEMA23 stepper motor with encoder
- **z-axis:** drylin® GRW cantilever axis with rack and pinion drive and NEMA17 stepper motor with encoder

Technical data

Workspace:	500 x 500 x 100mm
Max. speed:	0.5m/s
Max. acceleration:	1.5m/s ²
Repeatability:	0.8mm
Load capacity:	25N

DLE-RG-0002

- **x-axis:** drylin® ZLW-0630 toothed belt axis with NEMA23XL stepper motor with encoder
- **y-axis:** drylin® ZLW-0660 toothed belt axis with NEMA23 stepper motor with encoder
- **z-axis:** drylin® GRW-0630 cantilever axis with NEMA17 stepper motor with encoder

Technical data

Workspace:	400 x 400 x 150mm
Max. speed:	0.5m/s
Max. acceleration:	1.5m/s ²
Repeatability:	0.8mm
Load capacity:	25N

DLE-RG-0003

- **x-axis:** drylin® ZLW-1040 toothed belt axis with NEMA 23 XL stepper motor with encoder
- **y-axis:** drylin® ZLW-10120 toothed belt axis with NEMA 23 XL stepper motor with encoder
- **z-axis:** GRR-1280 rack axis with NEMA23 XL stepper motor with encoder

Technical data

Workspace:	800 x 800 x 500mm
Max. speed:	0.5m/s
Max. acceleration:	1.5m/s ²
Repeatability:	0.8mm
Load capacity:	50N

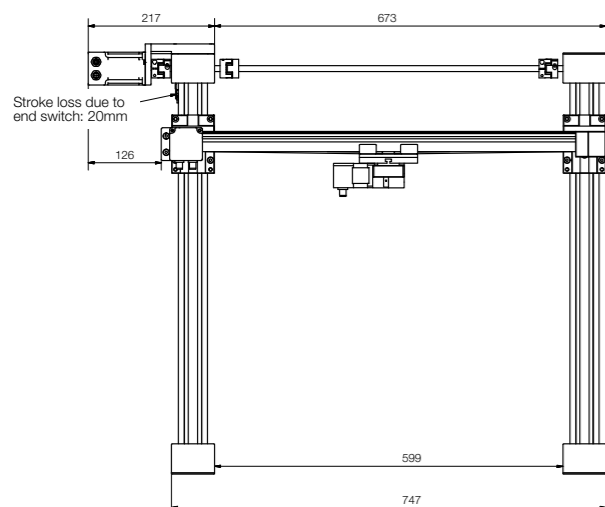

Part No.
DLE-RG-0001
DLE-RG-0002
DLE-RG-0003

My sketches

