



TS-01

TS-11

Order key

Type Options

TS-01-15-1000

- Guide rail
- Standard
- Installation size
- Rail length [mm]

Options:

TS-01: Standard rail, hard-anodised

TS-11: Weight-reduced rail, clear-anodised

Hard-anodised surfaces

► Page 958

Curved rail profiles  
► Page 962

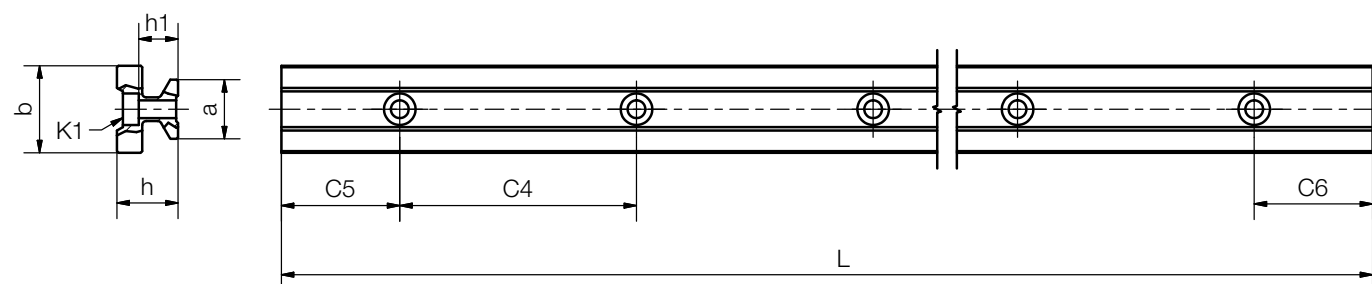

Dimensions [mm]

Part No.	Weight [kg/m]	L Max.	a -0.2	C4 Min.	C5 Max.	C5 Min.	C6 Max.	C6 Min.	h	h1	K1 for screw DIN 912	b	ly [mm²]	lz [mm²]	Wby [mm³]	Wbz [mm³]
TS-01-15	0.6	4,000	15	60	20	49.5	20	49.5	15.5	10.0	M4	22	6,440	4,290	585	488
TS-01-20	1.0	4,000	20	60	20	49.5	20	49.5	19.0	12.3	M5	31	22,570	11,520	1,456	1,067
TS-11-20	0.5	4,000	20	120	20	79.5	20	79.5	19.0	12.3	M5	31	12,140	6,360	780	620
TS-01-25	1.3	4,000	23	60	20	49.5	20	49.5	21.5	13.8	M6	34	34,700	19,300	2,041	1,608
TS-01-30	1.9	4,000	28	80	20	59.5	20	59.5	26.0	15.8	M8	40	70,040	40,780	3,502	2,832

Standard hole pattern symmetric C5 = C6

For rails without mounting holes, please use part number suffix "UNGEBOHRT"

Can be combined with:



Technical data  
► Page 1059



Order key

Type

TW-12-15

- Guide carriage
- High performance
- Installation size

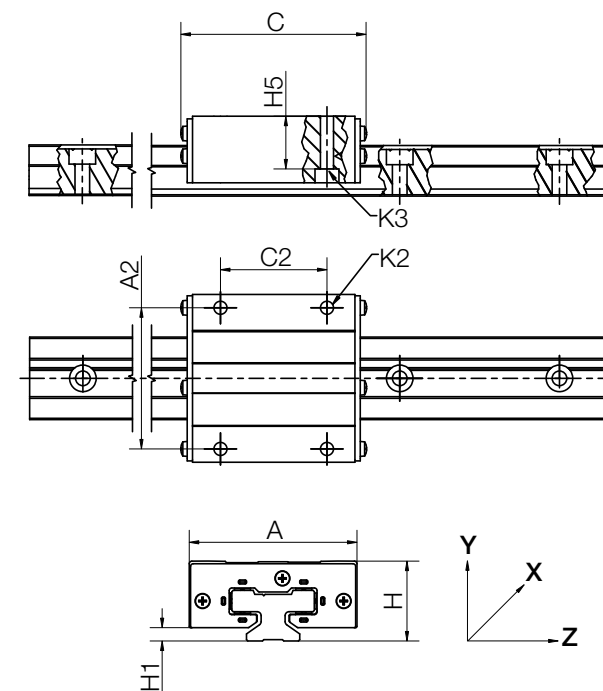

Dimensions [mm]

Part No.	Weight [kg]	H ±0.35	H5	A	C	A2	C2	H1 ±0.35	K2 thread	K3 for cap screw	Sliding elements
TW-12-15	0.11	24	16.0	47	63	38	30	4.0	M5	M4	iglidur® J200
TW-12-20	0.19	30	19.8	63	72	53	40	5.0	M6	M5	iglidur® J200
TW-12-25	0.29	36	24.8	70	82	57	45	5.0	M8	M6	iglidur® J200
TW-12-30	0.50	42	27.0	90	94	72	52	6.5	M10	M8	iglidur® J200

Can only be combined with:

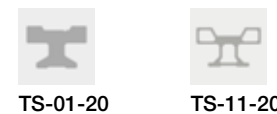

Technical data  
► Page 1059