

drylin® R pillow blocks | Product range

Split anodised aluminium housing, screwed, short design

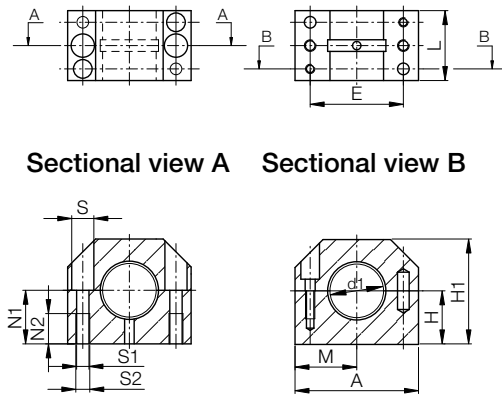

Order key

Type	Size
Open	T J U M-05-16
iglidur® J	
Liner	
Metric	
Compact	
Inner Ø d1	

● Replacement of the liner without removing the shaft

⁷⁸⁾ According to igus® testing method ► Page 1146
⁸²⁾ Design tips ► Page 1078
 Please note: Installation instructions ► Page 1079

Dimensions [mm]

d1	H ±0.02	H1	A	M	E ±0.15	S	S1	S2	N1	N2	L	Part No.
16	19	38	45	22.5	34	8.0	M5	4.3	18	11	30	TJUM-05-16
20	23	45	53	26.5	40	9.5	M6	5.3	22	13	30	TJUM-05-20
25	27	54	62	31.0	48	11.0	M8	6.6	26	18	40	TJUM-05-25
30	30	60	67	33.5	53	11.0	M8	6.6	29	18	50	TJUM-05-30
40	39	76	87	43.5	69	15.0	M10	8.4	38	22	60	TJUM-05-40

Technical data

Part No.	d1 tolerance ⁷⁸⁾		Fmax. dynamic ⁸²⁾		Fmax. static ⁸²⁾		Weight [g]
	[mm]		p = 5MPa		p = 35MPa		
			[N]		[N]		
TJUM-05-16	+0.030	+0.120	1,200		8,400		105
TJUM-05-20	+0.030	+0.120	1,500		10,500		137
TJUM-05-25	+0.030	+0.120	2,500		17,500		253
TJUM-05-30	+0.040	+0.135	3,750		26,250		377
TJUM-05-40	+0.040	+0.135	6,000		42,000		720

Available with drylin® liners (optional: J200/A180):



drylin® R pillow blocks | Product range

Closed, anodised aluminium housing, tandem design

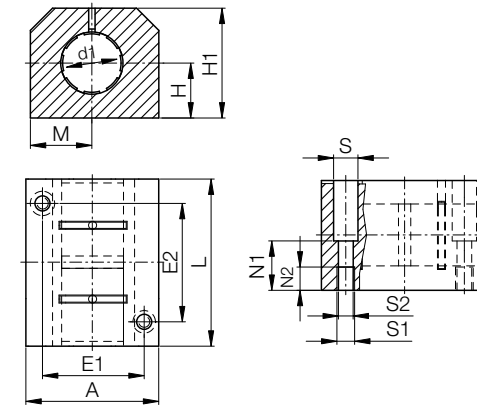

Order key

Type	Size
Closed	R J U M T-05-12
iglidur® J	
Liner	
Metric	
Tandem	
Compact	
Inner Ø d1	

● Tandem design
 ● Equipped with two liners to increase the guide length

⁷⁸⁾ According to igus® testing method ► Page 1146
⁸²⁾ Design tips ► Page 1078
 Please note: Installation instructions ► Page 1079

Dimensions [mm]

d1	H +0.01 -0.014	H1	A	M	E1 ±0.15	E2 ±0.15	S	S1	S2	N1	N2	L	Part No.
12	17	33	40	20	29	35	8.0	M5	4.3	16.0	11	60	RJUMT-05-12
16	19	38	45	22.5	34	40	8.0	M5	4.3	18.0	11	65	RJUMT-05-16
20	23	45	53	26.5	40	45	9.5	M6	5.3	22.0	13	65	RJUMT-05-20
25	27	54	62	31	48	55	11.0	M8	6.6	26.0	18	85	RJUMT-05-25
30	30	60	67	33.5	53	70	11.0	M8	6.6	29.0	18	105	RJUMT-05-30
40	39	76	87	43.5	69	85	15.0	M10	8.4	38.0	22	125	RJUMT-05-40
50	47	92	103	51.5	82	100	18.0	M12	10.5	46.0	26	145	RJUMT-05-50

Technical data

Part No.	d1 tolerance ⁷⁸⁾		Fmax. dynamic ⁸²⁾		Fmax. static ⁸²⁾		Weight [g]
	[mm]		p = 5MPa		p = 35MPa		
			[N]		[N]		
RJUMT-05-12	+0.030	+0.088	840		5,880		170
RJUMT-05-16	+0.030	+0.088	1,200		8,400		250
RJUMT-05-20	+0.030	+0.091	1,500		10,500		300
RJUMT-05-25	+0.030	+0.091	2,500		17,500		550
RJUMT-05-30	+0.040	+0.110	3,750		26,250		750
RJUMT-05-40	+0.040	+0.115	6,000		42,000		1,500
RJUMT-05-50	+0.050	+0.150	8,750		61,250		2,400

Available with drylin® liners (optional: J200/A180):

