

drylin® W carbon fibre | Product range

Linear guide system – extremely lightweight and strong



Order key
Complete solution

| Type | Dimensions [mm]/Type |
|------|----------------------|
|------|----------------------|

W K P C-06-30-06

| | | | | | | |
|-----------|-----------------|---------|--------------|---------|------------|-----------------|
| drylin® W | Complete system | Plastic | Carbon fibre | Shaft Ø | Rail width | Carriage length |
|-----------|-----------------|---------|--------------|---------|------------|-----------------|

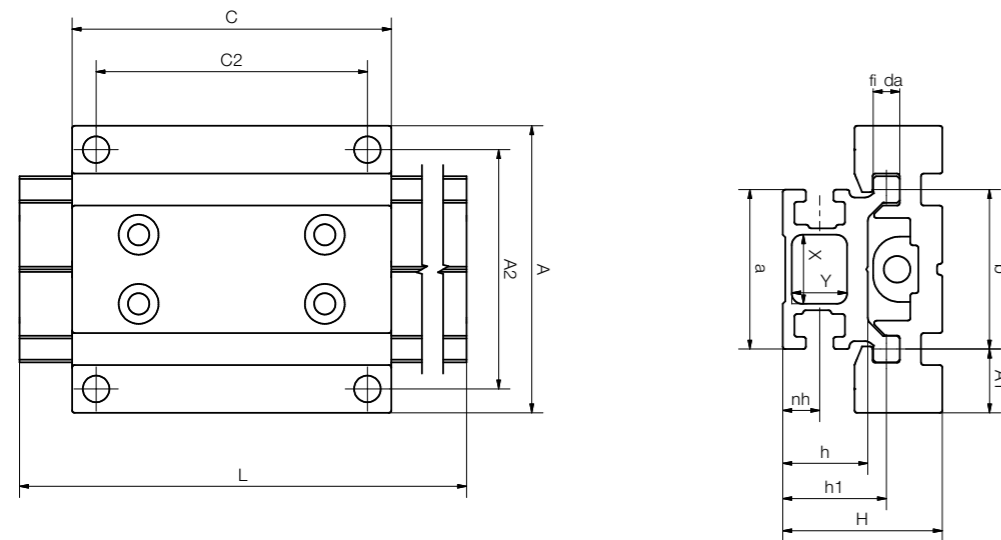

Technical data – guide rail made from carbon

| Part No. | F max. radial | | Weight | I _y | I _z |
|------------|---------------|----------|--------|----------------|----------------|
| | stat. [N] | dyn. [N] | | | |
| WSPC-06-30 | 300 | 60 | 410 | 30,391 | 11,674 |

Dimensions [mm] – guide profile made from carbon

| Part No. | a | b | da | h | h1 | nh | X | Y | L |
|------------|----|----|------|----|------|----|----|----|-------|
| WSPC-06-30 | 30 | 30 | -0.1 | 16 | 19.5 | 7 | 13 | 10 | 3,000 |

Dimensions [mm] solid plastic guide carriage made from iglidur® polymer

| Part No. | H | A1 | A | A2 | C | C2 |
|---------------|----|----|----|----|----|----|
| WWPL-06-30-06 | 30 | 12 | 54 | 45 | 60 | 51 |

drylin® ZLW carbon fibre | Product range

Toothed belt axis – non-metallic



Order key

| Type | Dimensions [mm]/Type |
|------|----------------------|
|------|----------------------|

ZLW-06 30-P-1000

| | | | | |
|-------------------|---------|------------|---------|---------------|
| Toothed belt axis | Shaft Ø | Rail width | Plastic | Stroke length |
|-------------------|---------|------------|---------|---------------|

- Guide profile made from carbon
- Linear carriage made from iglidur® polymer

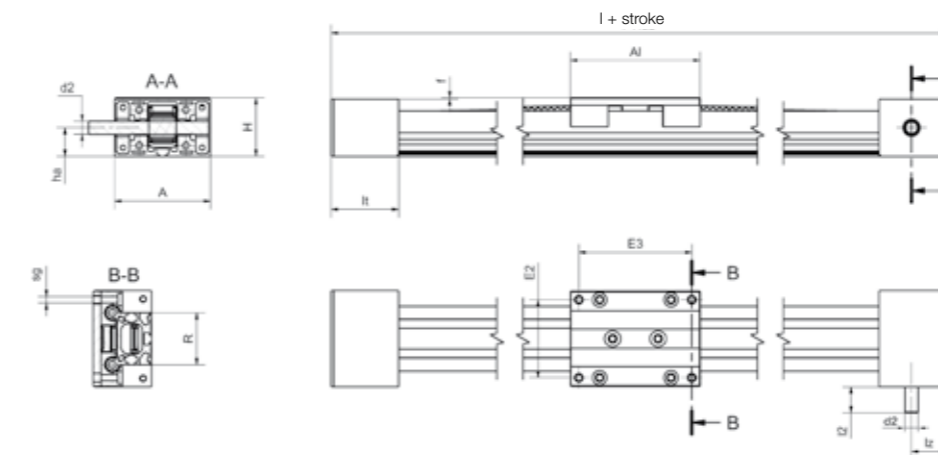

Connection size

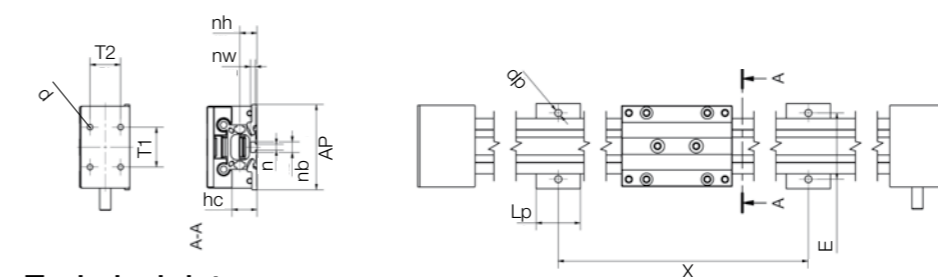

Technical data

| Part No. | Weight without stroke [kg] | Weight 100mm stroke [kg] | Max. stroke length [mm] | Transmission [mm/rev] | Tooth profile | Drive belt | | |
|------------|----------------------------|--------------------------|-------------------------|-----------------------|---------------|------------------|-------------|--------------|
| | | | | | | -material | -width [mm] | -tension [N] |
| Basic 02 P | 0.3 | 0.08 | 1,000 | 54 | HTD 3M | Neoprene with GF | 9 | 25 |

Dimensions [mm]

| Part No. | A | AI | H | E2 | E3 | I | R | f | It | ha | Iz | I2 | d2 |
|------------|------|----|----|-------|-------|-----|-------|---|------|----|----|----|----|
| ZLW-0630-P | -0.3 | | 31 | ±0.15 | ±0.15 | 144 | ±0.15 | 3 | -0.3 | 14 | 20 | 20 | h9 |

Connection size

| Part No. | X | E | AP | Lp | dp | d | T1 | T2 |
|------------|----------|------|------|----|-----|---|-------|------|
| ZLW-0630-P | variable | ±0.2 | -1.0 | 15 | 5.5 | 3 | ±0.25 | -0.3 |