

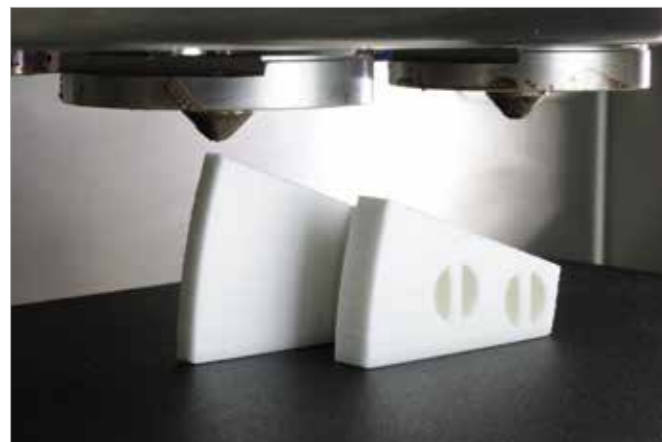

...plastics



3D printing/SLS

For prototypes or small quantities made from tribo-filaments with the laser sintering method

Wear-resistant materials for 3D printing and the laser sintering method – print parts yourself or have igus® print them for you.

- Up to 50-times more abrasion-resistant than normal 3D printing materials
- Various iglidur® materials available for FDM/FFF (filament) and SLS (powder)
- No tool costs; cost-effective, no minimum order quantity

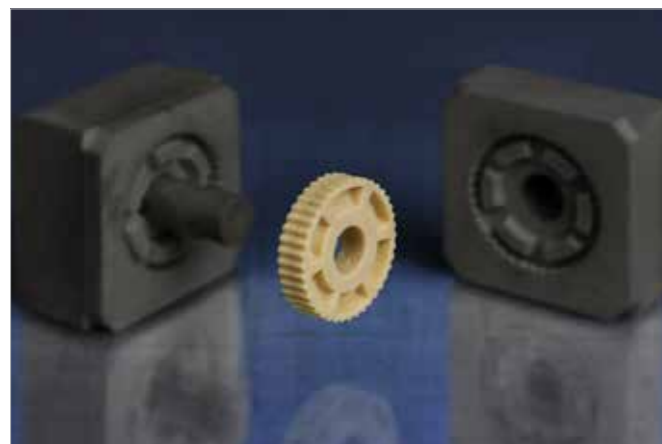

Printed tools

For small quantities made from iglidur® granules

3D printed mould tools to produce Wear-resistant injection-moulded parts made in all available iglidur® materials.

- Customised parts delivered from 4 business days
- Up to 80% more cost-effective than conventional injection mould tools
- For prototypes and small volumes
- Check price and manufacturability online
▶ www.igus.eu/idd

Lubrication-free printing

Extremely abrasion and wear-resistant tribo-plastics for additive manufacturing via selective laser sintering (SLS) or with filament (FDM/FFF) allow you to use the printed component or to test the function of the part reliably and completely from the prototype or production batch onward.

- Abrasion-resistant
- Lubrication and maintenance-free
- No tooling costs
- Design freedom
- 3D printing of parts on site
- Can be processed by commercially available 3D printers
- Predictable service life
- Surfaces smoothed or coloured in one of 12 standard colours
- 3D printing service 24–72hrs

Typical application areas

- Special wear-resistant parts
- Jig construction
- Single pieces and small volumes

 **Available from stock**
Detailed information about delivery time online.

 **More information about 3D printing**
▶ www.igus.eu/3d

 **Calculate service life of 3D printed plain bearings online**
▶ www.igus.eu/iglidur-expert

 **Calculate service life for 3D printed gears online**
▶ www.igus.eu/gear-expert

 **Create a 3D model of the gear, roller, and much more within one minute**
▶ www.igus.eu/cad-configurators

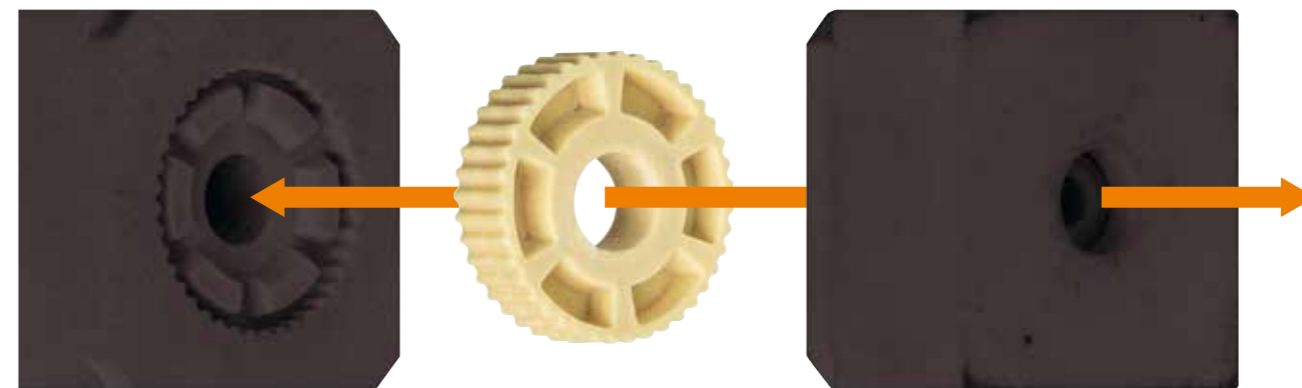

Tools for injection moulding from the 3D printers

Due to 3D printing, igus® is able to make customised injection moulds in a short time with up to 80% lower costs. Maintenance-free plastic plain bearings in the required shape can be made quickly and, above all, cost-effectively from all iglidur® materials.

- High variety of materials: all iglidur® plain bearing materials can be requested as samples
- Cost-efficient and delivered quickly
- No minimum order quantity
- For simple geometries
- For large quantities and recurring projects, metal 3D-printed moulds can also be provided.
- **Prices online** ▶ www.igus.eu/idd

The manufacture of maintenance-free plastic plain bearings from 3D printed injection moulds is worthwhile compared to direct 3D printing of the iglidur® materials especially if:

- Special material characteristics are needed, such as conductivity, high temperature, underwater use, KTW compliance
- Small volumes in the same iglidur® material are to be sampled as is a later high volume from a classic injection moulding tool

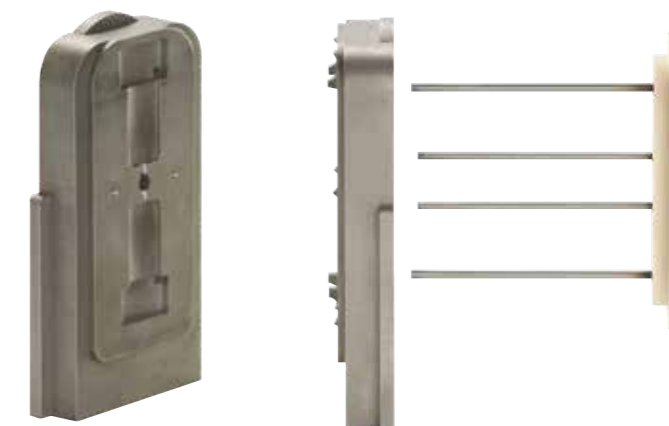

 **Delivery time**
from 5 business days

 ▶ www.igus.eu/3d-tools

 **Information**
▶ www.igus.eu/print2mold

 **Prices**
▶ www.igus.eu/idd



At least 3 times more wear-resistant: iglidur® I3 for 3D printing via SLS

The material iglidur® I3, specially developed for laser sintering, proved to have an abrasion resistance 3 to 30 times higher than conventional materials for laser sintering during tribological tests in the igus® test laboratory. This means the degree of design freedom for wear-resistant parts has been further increased. iglidur® I3 is also suitable for regular gears such as spur gears, bevel gears, and planetary gears.

- Lubrication and maintenance-free
- Wear-resistant
- Good mechanical properties
- Detail accuracy with exact surfaces
- Can be processed using the standard parameter set
- Refresh rate: 75%
- Automotive-compliant according to FMV SS 302
- Gear service life calculation
▶ www.igus.eu/gear-expert
- igus 3D printing service ▶ www.igus.eu/idd
- Most-popular igus® 3D-printing material (more than 100,000 parts per year)

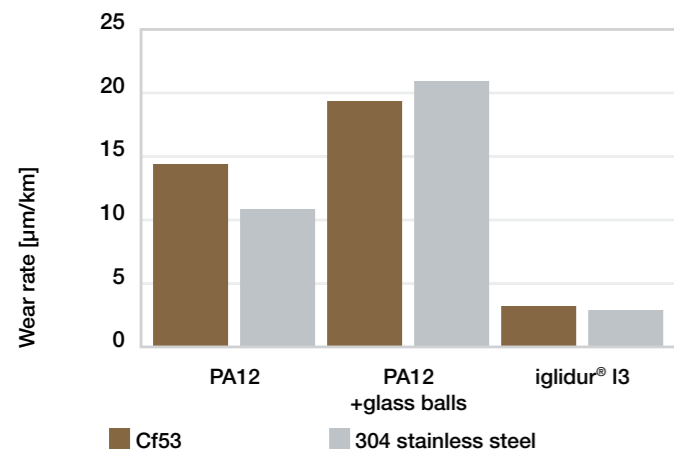

Rotating wear: p = 1MPa; v = 0.3m/s

Delivery time
72hrs

Material properties

General properties	Unit	iglidur® I3	Testing method
Density	g/cm³	1.05	
Colour		Yellow	
Max. moisture absorption at +23°C/50% r. h.	% weight	0.8	DIN 53495
Max. total moisture absorption	% weight	1.9	
Mechanical properties			
Flexural modulus	MPa	1,400	DIN 53457
Flexural strength at +20°C	MPa	68/61 ¹³⁰⁾	DIN 53452
Shore D hardness		70	DIN 53505
Physical and thermal properties			
Max. long-term application temperature	°C	+80	
Max. short-term application temperature	°C	+140	
Min. continuous application temperature	°C	-40	
Electrical properties			
Specific contact resistance	Ωcm	> 10 ¹²	DIN IEC 93
Surface resistance	Ω	> 10 ¹¹	DIN 53482

¹³⁰⁾ Printed flat/upright

▶ Chemical table, page 1636

Part No. raw material (10kg)
I3-PL-10000

Part No. component
I3-PS-02

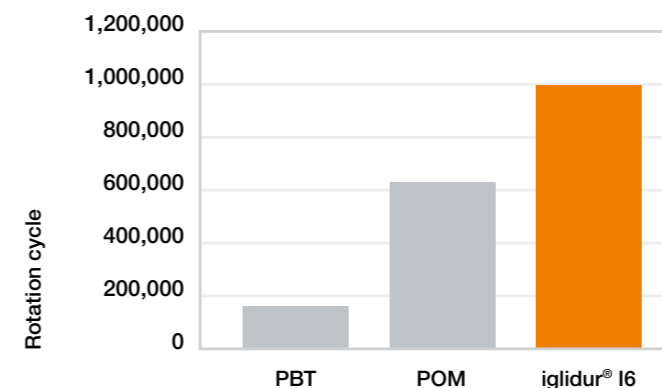

Service life test worm wheel. 12rpm; 4.9Nm

Delivery time
72hrs

Material properties

General properties	Unit	iglidur® I6	Testing method
Density	g/cm³	1.06	
Colour		white	
Max. moisture absorption at +23°C/50% r. h.	% weight	0.8	DIN 53495
Max. total moisture absorption	% weight	1.9	
Mechanical properties			
Flexural modulus	MPa	1,100	DIN 53457
Flexural strength at +20°C	MPa	49/38 ¹³⁰⁾	DIN 53452
Shore D hardness		67	DIN 53505
Physical and thermal properties			
Max. long-term application temperature	°C	+80	
Max. short-term application temperature	°C	+140	
Min. continuous application temperature	°C	-40	
Electrical properties			
Specific contact resistance	Ωcm	> 10 ¹²	DIN IEC 93
Surface resistance	Ω	> 10 ¹¹	DIN 53482

¹³⁰⁾ Printed flat/upright

▶ Chemical table, page 1636

Part No. raw material (10kg)
I6-PL-10000

Part No. component
I6-PS-02

Durable worm wheels made of iglidur® I6 via laser sintering

The material iglidur® I6 was specifically developed for laser sintering and is especially suited for worm wheels. The tests in the igus® test laboratory showed a longer service life than conventional machined POM worm wheels. This greatly increases the flexibility in the design of gears, since no tools are necessary due to the laser sintering process and worm wheels can be produced efficiently without minimum order quantity.

- Abrasion-resistant
- Extremely long operating times
- Lubrication and maintenance-free
- Cost-efficient from batch size 1
- No tooling costs
- Delivery time 24-72hrs
- Detail accuracy with exact surfaces
- igus 3D printing service ▶ www.igus.eu/idd
- Also suitable for medium-sized series, e.g. 5,000 pieces
▶ www.igus.eu/gear

Wear-resistant parts from the 3D printing service

Online and extremely fast

Printed parts extremely wear-resistant- as prototype or in small series. Simply upload your required part, determine the price and order online (or ask for a quotation). Thanks to the iglidur® 3D printing service, from now on 2 quick and easy steps will complete your customised component made of lubrication-free and abrasion-resistant iglidur® plastics. The service life of the 3D printed components is comparable to igus® injection moulded parts. In the online 3D printing calculation, you can not only receive 3D printing, but also analyse feasibility and prices of injection-moulded parts made with 3D-printed moulds (print2mold).

- 1 Go to www.igus.eu/idd and upload the 3D model in the STEP format. The manufacturability (wall thickness and component size) is analysed automatically
 - 2 Select material and quantity and order the component or ask for a quotation.
- **Your individual wear-resistant part will be shipped in 24–72 hours**

 **Delivery time**
24–72hrs

 **Try it out now:**
► www.igus.eu/idd

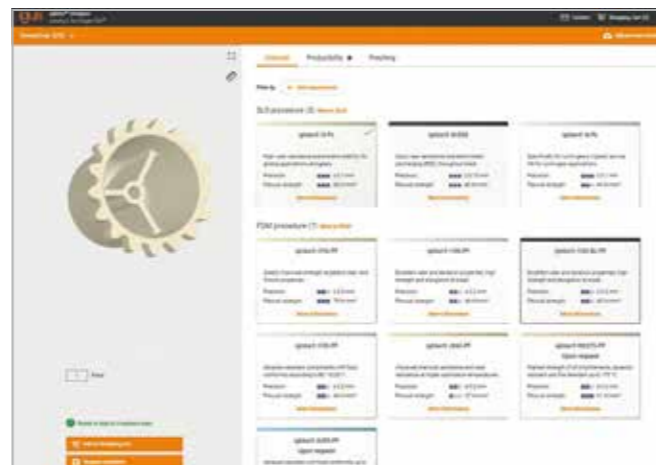

Material selection

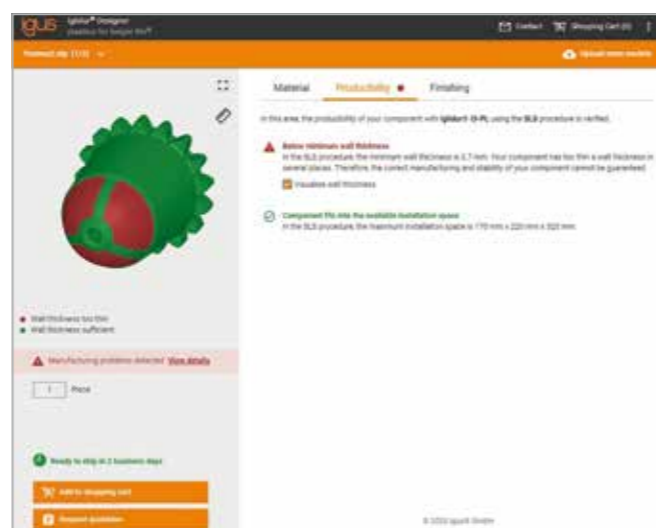

Wall thickness analyses

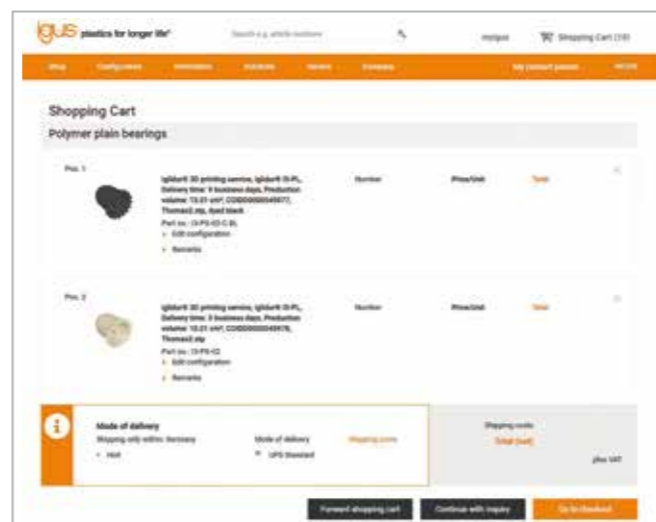

Shopping cart

SLS can also be used to make wear-resistant parts

The 3D printing service is being extended with the materials iglidur® I3 and iglidur® I6. Laser sintering (SLS) is used to make parts of these materials. With this method even more plain bearing applications are therefore possible with 3D-printed parts, strength and precision are considerably greater and the price per component is lower.

New: additional laser sintering services

In the 3D printing service, more services for laser sintering materials can now be selected and their prices easily defined.

- Black colouring for visible parts
- Polish surfaces using vibratory finishing or chemical polishing

Two-component 3D printing (FDM/FFF)

Two-component parts made of proven tribo-filaments and fibre-reinforced plastics for stability and rigidity, can be ordered upon request.



Dimensional stability and size of installation space

The precision of the printed parts in the case of the iglidur® tribo-filaments is $\pm 0.2\text{mm}$ (up to an edge length of 50mm, above this $\pm 0.4\%$). In the case of parts made using the laser sintering process the precision is $\pm 0.1\text{mm}$ (up to an edge length of 50mm, above this $\pm 0.2\%$).

The space used for processing the iglidur® tribo-filaments measures 135x145x200mm. In the case of laser sintering the space used measures 170x220x300mm. The following applies to both processes: larger parts may have to be made of several pieces.

In order to ensure that the 3D-printed components function correctly, the following should be included in the 3D model:

- The 3D model should be at the centre of tolerance; e.g. for a tolerance of $16 - 0.2\text{mm}$, the 3D model should correspond to 15.9mm
- In the case of clearance fits, a play of approx. 0.1mm should be planned
- Minimum wall thickness: SLS 0.7mm, FDM/FFF 1mm

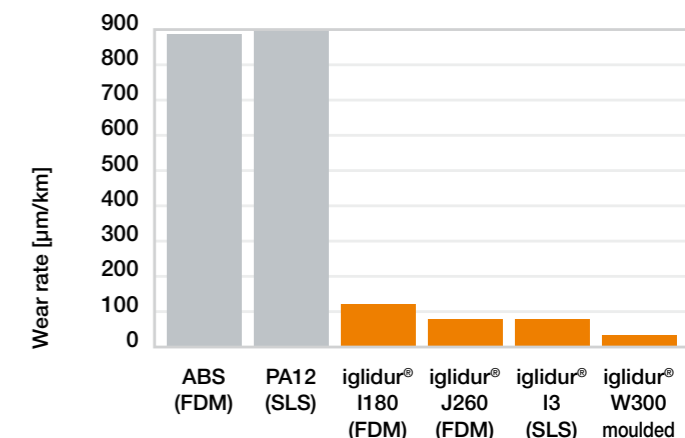

Wear, rotating $p = 20\text{ MPa}$; $v = 0.01\text{m/s}$, 304 stainless steel

iglidur® tribo 3D printing | Gear configurator

Wear-resistant gears in 60 seconds using the new igus® gear configurator

Configure individual gears and racks in 60 seconds and they will be ready for shipment within 3 days

In order to facilitate the work of designers, igus® has now developed simple and practical configurators for gears and racks. This allows each customer to configure their own component even in special dimensions. In a few steps, the user only needs to enter the specifications of the required gear; such as the tooth module, number of teeth, width and inner diameter, or select a suitable rack profile. This automatically displays a 3D model that can be exported as a STEP file. If the file is uploaded in the framework of the igus® 3D printing service ► www.igus.eu/3dprintservice, the configured gear made of the new durable SLS material iglidur® I3 for gears can be ordered immediately from igus®. With one click, the user can order his/her wear-resistant gear with no minimum order quantity or request a quotation. Within 3 days the custom-made gear is ready for shipment. iglidur® I3 is well suited for straight and helical spur gears, racks, and bevel gears.

Gear service life calculator
► www.igus.eu/gear-expert

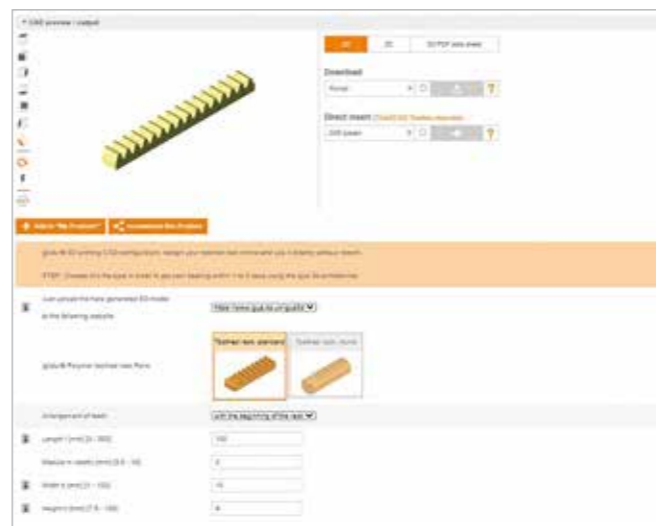
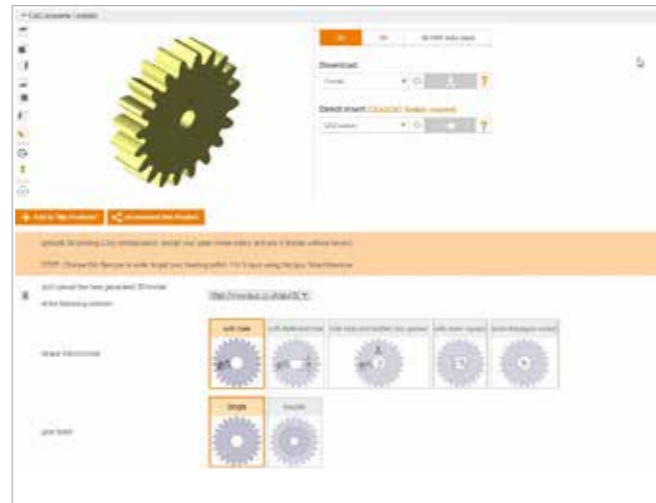

iglidur® I6 for worm gears: double the service life

In the test, iglidur® I6 showed itself to be considerably better than machined worm wheels. Worm wheels made of POM had total wear after 621,000 cycles, whereas worm wheels made of iglidur® I6 continued to be functional after more than 1 million cycles.

Delivery time
24–72hrs

Online CAD configurator for gears
► www.igus.eu/gear-configurator



POM	POM	iglidur® I6
321,000 cycles	621,000 cycles	1 million cycles
High wear	Failed	Low wear

Online CAD configurator for plain bearings
► www.igus.eu/3d-model



iglidur® tribo 3D printing | Configurators

Individual rollers, lead screw nuts, and sliding plates

Configure rollers in the required shape online, delivered after a minimum of only 24hrs

Create and download your individual 3D model with the roller configurator. Then order it from the 3D printing service (shipped in one to three days). Rollers with different shapes and with any dimensions between 1 and 170mm are possible. The rollers can be used immediately without any further machining.

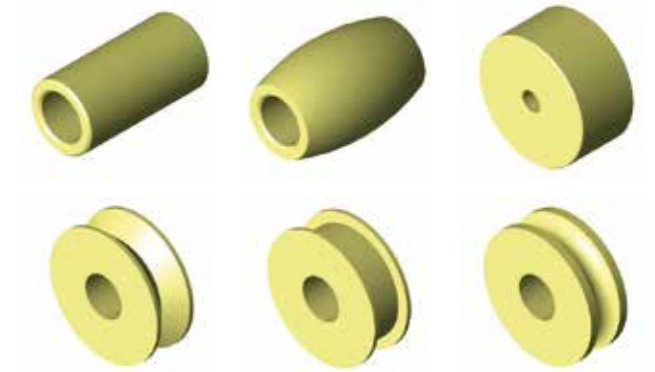
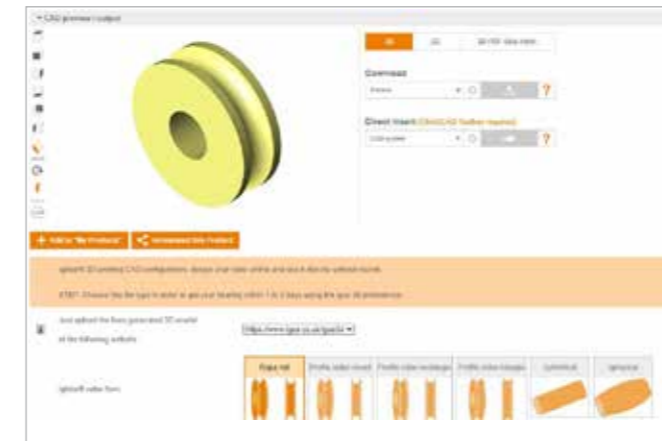

Delivery time
24–72hrs

Configure rollers
► www.igus.eu/roller-configurator

Configure custom lead screw nuts, plain bearings and sliding plates in 60 seconds and they will be ready for shipment within 3 days

In addition to individually configurable sliding plates and plain bearings, lead screw nuts with trapezoidal threads can be manufactured from a 3D model. Eliminates costly, time-consuming design and rework. Lead screw nuts, plain bearing, and sliding plates are manufactured from iglidur® I3 (laser sintering).

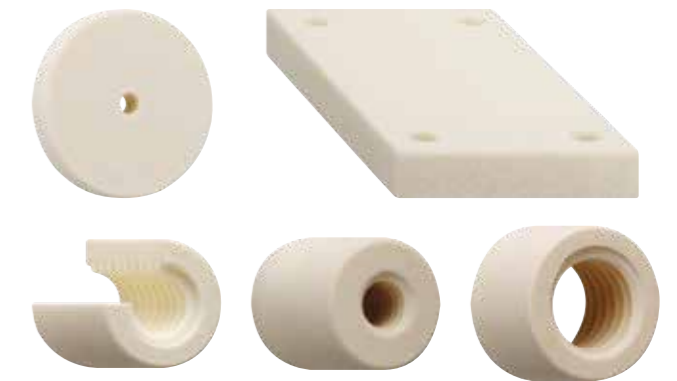

Lead screw nut wear test

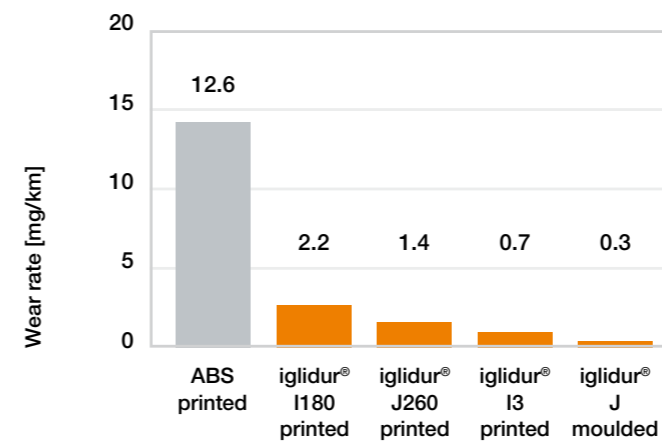

F = 129N; l = 370mm; n = 290rpm



Delivery time
24–72hrs

All configurators
► www.igus.eu/cad-configurators

Configure gear with and without keyway



Image exemplary

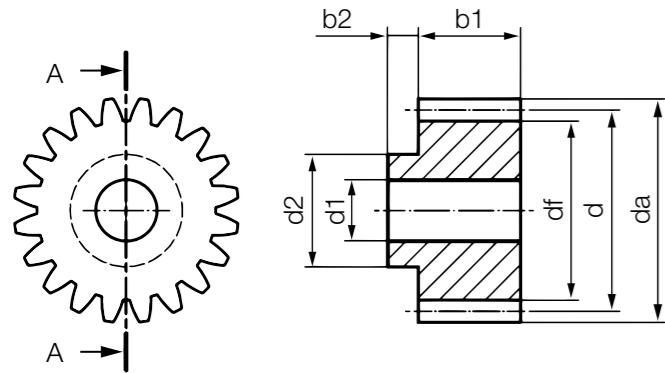

Configuration key

Part type	Options
OC-GEAR-01-1.00-18-10.0-6.1-20.0-8.0	
Configurator	Gear type
	Tooth module
	Number of teeth
	Width b1
	Inner diameter d1
	Diameter outlet b2
	Width outlet b2

Configuration limits:

Gear type 01: gear with hole, keyway optional
 Tooth module: 0.50 to 10.0mm
 Number of teeth: 17 to 100
 Width: 1.0 to 200mm

Dimensions [mm] – example gear configuration with and without keyway

Part No.	Configuration number	Tooth module	Number of teeth	Width b1	Inner Ø d1	Keyway Ø b2	Width outlet b2
I3-PS-02	OC-GEAR-01-1.00-□-10-6-15	1.00	17–100	10	6	15	8
I3-PS-02	OC-GEAR-01-1.50-□-10-10-25	1.50	17–100	10	10	25	10
I3-PS-02	OC-GEAR-01-2.00-□-12-10	2.00	17–100	12	10	–	–
I3-PS-02	OC-GEAR-01-2.50-□-14-12	2.50	17–100	14	12	–	–



Many other gear types, including double gears, can be configured online: download the STEP model and determine the price online ► www.igus.eu/gear-configurator

Delivery time
72hrs

710 Try it out now ► www.igus.eu/cad-configurators



Configure round and flat racks

Rack, flat



Image exemplary

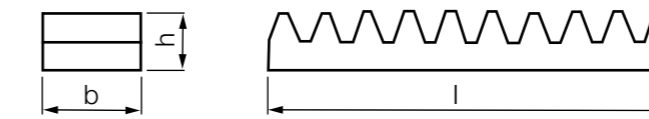

Configuration key rack, flat

Part type	Options
OC-GEAR-RACK-01-1.00-10.0-4.5-60.0- S	
Configurator	Rack type
	Tooth module
	Width b
	Height h
	Length l
	Arrangement

Configuration limits:

Rack type 01: flat rack
 Tooth module: 0.50 to 10.0mm
 Width: 1.0 to 100mm
 Height: up to 100mm
 Length: 3 to 300mm¹⁷³⁾
 Arrangement S: Symmetrical end separation

Dimensions [mm] – example configuration of flat rack

Part No.	Configuration number	Tooth module	Width b	Height h	Length l	Arrangement
I3-PS-02	OC-GEAR-RACK-01-1.00-10.0-10.0-□-S	1.00	10.0	10.0	3–300	S
I3-PS-02	OC-GEAR-RACK-01-1.50-15.0-15.0-□-S	1.50	15.0	15.0	3–300	S
I3-PS-02	OC-GEAR-RACK-01-2.00-20.0-20.0-□-S	2.00	20.0	20.0	3–300	S
I3-PS-02	OC-GEAR-RACK-01-2.50-20.0-20.0-□-S	2.50	20.0	20.0	3–300	S

¹⁷³⁾ Also has multiple parts

Configure an individual rack, download the STEP model, and determine the price online ► www.igus.eu/rack-configurator

Delivery time
72hrs



Rack, round

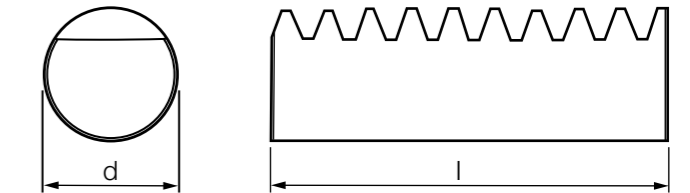

Configuration key rack, round

Part type	Options
OC-GEAR-RACK-02-1.00-10.0-60.0- S	
Configurator	Rack type
	Tooth module
	Diameter d
	Length l
	Arrangement

Configuration limits:

Rack type 02: round rack
 Tooth module: 0.50 to 10.0mm
 Diameters: 3.0mm up to 100mm
 Length: 3 to 300mm¹⁷³⁾
 Arrangement S: Symmetrical end separation

Prices and delivery time online ► www.igus.eu/idd 711

Configure plain bearings with and without flange

Sleeve bearing

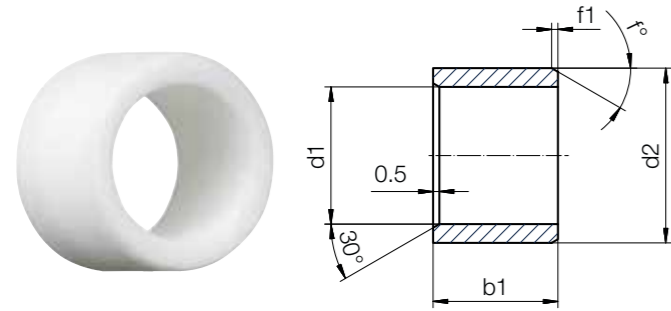

Flanged bearings

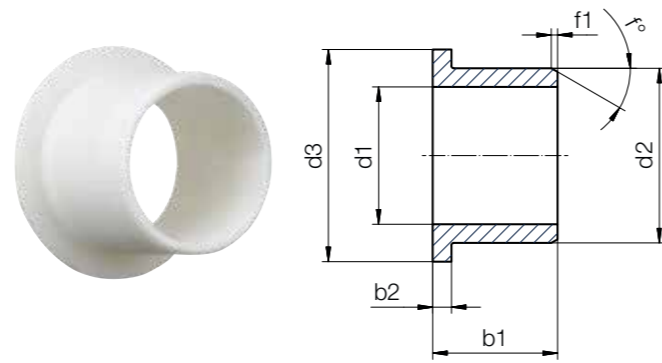

Configuration key Sleeve bearing

Part type	Options
-----------	---------

OC-BRG-S-10.0-12.0-10.0

Configurator	Plain bearing type	Inner Ø d1	Outer Ø d2	Total length b1
--------------	--------------------	------------	------------	-----------------

Configuration limits:

Plain bearing type S: sleeve bearing
 Inner diameter: up to 195mm
 Outer diameter: up to 200mm
 Bearing length: up to 300mm

Configuration key Flanged bearings

Part type	Options
-----------	---------

OC-BRG-F-10.0-12.0-10.0-16.0-1.0

Configurator	Plain bearing type	Inner Ø d1	Outer Ø d2	Total length b1	Flange Ø	Flange thickness
--------------	--------------------	------------	------------	-----------------	----------	------------------

Configuration limits:

Plain bearing type F: flanged bearing
 Inner diameter: up to 195mm
 Outer diameter: up to 200mm
 Bearing length: up to 300mm
 Flange diameter: up to 200mm
 Flange thickness: up to 20mm

Dimensions [mm] – example plain bearing configuration with and without flange

Part No.	Configuration number	Inner Ø	Outer Ø	Total length	Flange Ø	Flange thickness
		d1	d2	b1	d3	b2
I3-PS-02	OC-BRG-S-50.0-60.0-30.0	50.0	60.0	30.0	–	–
I3-PS-02	OC-BRG-S-18.0-20.0-16.0	18.0	20.0	16.0	–	–
I3-PS-02	OC-BRG-F-18.0-22.0-18.0-30.0-1.0	18.0	22.0	18.0	30.0	1.0
I3-PS-02	OC-BRG-F-50.0-60.0-31.0-66.0-1.0	50.0	60.0	31.0	66.0	1.0



Configure an individual plain bearing, download the STEP model, and determine the price online, including special shapes with slot ► www.igus.eu/3d-model

Delivery time
72hrs

Configure convex rollers

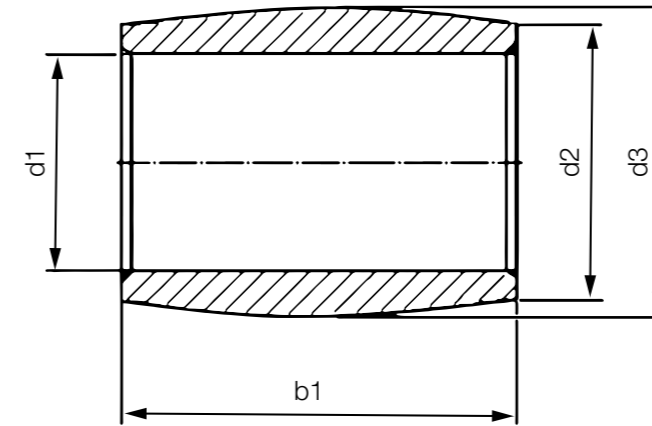

Configuration key

Part type	Options
-----------	---------

OC-ROLLER-02-10.0-15.0-30.0-20.0

Configurator	Roller type	Inner Ø d1	Outer Ø d2	Spherical outer Ø d3	Roller length
--------------	-------------	------------	------------	----------------------	---------------

Configuration limits:

Roller type 02: convex roller
 Inner diameter: 1 up to 190mm
 Outer diameter: up to 195mm
 Roller length: up to 300mm

Dimensions [mm] – example configuration of convex rollers

Part No.	Configuration number	Inner Ø	Outer Ø	Spherical	Max.
		d1	d2	Outer Ø	Roller length
				d3	b1
I3-PS-02	OC-ROLLER-02-4.0-8.0-8.2-□	4.0	8.0	8.2	300
I3-PS-02	OC-ROLLER-02-10.0-15.0-20-□	10.0	15.0	20	300
I3-PS-02	OC-ROLLER-02-10.0-50.0-55.0-□	10.0	50.0	55.0	300
I3-PS-02	OC-ROLLER-02-14.0-60.0-61.0-□	14.0	60.0	61.0	300
I3-PS-02	OC-ROLLER-02-20.0-100.0-120.0-□	20.0	100.0	120.0	300



Many other roller types can be configured online: download the STEP model and determine the price online ► www.igus.eu/roller-configurator

Delivery time
72hrs



Image exemplary

Configuration key

Part type	Options
OC-NUT-S-18.0-12.0-TR10X2-R	
Configurator	Lead screw nut type
	Outer Ø d2
	Width b1
	Thread
	Thread direction

Configuration limits:

Lead screw nut type S: cylindrical
 Outer diameter: up to 150mm
 Width: 3 to 200mm
 Thread: 32 types to select from
 Thread direction: R = Right hand
 L = Left

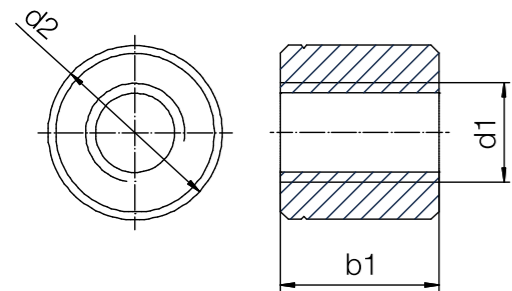

Dimensions [mm] – example configuration of cylindrical lead screw nut

Part No.	Configuration number	Outer Ø d2	Width b1	Thread	Thread direction	
					right	left
I3-PS-02	OC-NUT-S-15.0-□-TR8X1.5-R	15.0	3–200	TR8X1.5	●	–
I3-PS-02	OC-NUT-S-16.0-□-TR10X2-L	16.0	3–200	TR10X2	–	●
I3-PS-02	OC-NUT-S-18.0-□-TR11X5-R	18.0	3–200	TR11X5	●	–
I3-PS-02	OC-NUT-S-22.0-□-TR16X2-R	22.0	3–200	TR16X2	●	–
I3-PS-02	OC-NUT-S-26.0-□-TR20X2-L	26.0	3–200	TR20X2	–	●
I3-PS-02	OC-NUT-S-50,0-□-TR30X3-R	50.0	3–200	TR30X3	●	–



Configure individual trapezoidal lead screw nuts, download the STEP model and determine the price online ► www.igus.eu/lead-screw-nut-configurator

Delivery time
72hrs

Round sliding element with central hole



Image exemplary

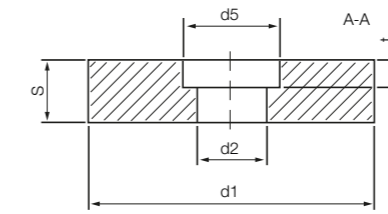

Configuration key
Round sliding element with central hole

Part type	Options
OC-SLIDER-01-6.4-30.0-10.0-13.0-5.0	
Configurator	Glider type
	Inner Ø d1
	Outer Ø d2
	Thickness s
	Flat sink d5
	Flat sink depth t

Configuration limits:

Glider Type 01: Round with central hole
 Inner diameter: up to 195mm
 Outer diameter: up to 200mm
 Height 2: up to 100mm
 Flat sink: optional

Dimensions [mm] – example plain bearing configuration with and without flange

Part No.	Configuration number	Width	Length	Pitch	Height	Hole	Flat sink	Flat sink
		b1	l1	l2	s	d3	d5	depth t
I3-PS-02	OC-SLIDER-04-20.0-40.0-20.0-10.0-6.4-13.0-5.0	20.0	40.0	20.0	10.0	6.4	13.0	5.0
I3-PS-02	OC-SLIDER-04-30.0-60.0-40.0-8.0-4.3-9.0-4.4	30.0	60.0	40.0	8.0	4.3	9.0	4.4
I3-PS-02	OC-SLIDER-04-50.0-100.0-60.0-11.0-8.2	50.0	100.0	60.0	11.0	8.2	–	–

Many other glider types can be configured online: download the STEP model and determine the price online ► www.igus.eu/glider-configurator

Delivery time
72hrs

Rectangular sliding element with 2 holes



Image exemplary

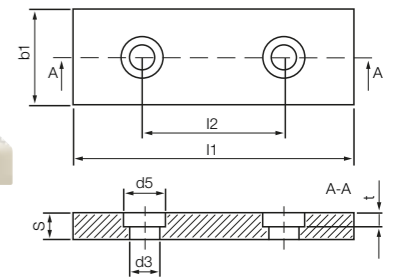

Configuration key
Rectangular sliding element with 2 holes

Part type	Options
OC-SLIDER-04-20.0-40.0-20.0-10.0-6.4-13.0-5.0	
Configurator	Glider type
	Width b1
	Length l1
	Pitch l2
	Thickness s
	Hole d3
	Flat sink d5
	Flat sink depth t

Configuration limits:

Glider Type 04: Rectangle with two holes
 Width: 10 to 200mm
 Length: 10 to 200mm
 Flat sink: optional
 Glider type:
 01 Round with central hole
 02 Round with 4 holes
 03 Round with 5 holes
 04 Rectangle with 2 holes
 05 Rectangle with 4 holes

3D printing with tribo-filaments

50 times more abrasion-resistant than standard materials for maximum service life
Components made of igus® tribo-filament are up to 50 times more wear-resistant than standard materials for 3D printing and therefore have an extremely long service life. Due to their excellent tribological properties, they are suited for 3D printing of replacement and wear-resistant parts for e.g. plain bearings, drive nuts, gears and other wear-resistant parts.
The igus® tribo-filaments can be processed on 3D printers that are based on the fused-deposition-modelling method (FDM/FFF) and that allow the nozzle temperature to be set as required.

 **Find and order the appropriate tribo-filament online**
▶ www.igus.eu/tribofilament



"How do I assess myself and my 3D printer?"

Ambient temperature of application	Beginner "Nothing can go wrong"	Advanced "Everything is usually ok"	Expert "I know what I am doing"
-30°C to +65°C	iglidur® I150	iglidur® I150 iglidur® I180	iglidur® I180 / iglidur® J260 iglidur® I170
-40°C to +80°C	iglidur® I180	iglidur® I180	iglidur® I180 / iglidur® J260 iglidur® I170
-30°C to +100°C			iglidur® J260 iglidur® C210
-100°C to +120°C			iglidur® J260
-100°C to +180°C			iglidur® A350 / iglidur® J350 iglidur® RW370 ¹⁷²⁾

¹⁷²⁾ -50°C to +170°C for iglidur® RW370



Material:
iglidur® I150

Wear-resistant parts printed the easy way

- High abrasion resistance at low speeds
- Good mechanical properties
- The easiest to process tribo-filament (even without a heated print bed)
- Food-compatible according to EU10/2011 regulation
- Nozzle temperature: +240°C up to +250°C

▶ Page 720



Material:
iglidur® J260

Extremely long service life and excellent coefficient of friction

- Outstanding abrasion resistance of tribo-filaments
- Application temperature from -100°C to +120°C
- High-quality processing
- Nozzle temperature: +260°C up to +270°C

▶ Page 722



Material:
iglidur® I170

Longer service life

- Improved abrasion resistance
- High-quality processing
- Nozzle temperature: +240°C up to +260°C

▶ Page 724



Material:
iglidur® RW370

Ideal for rail technology

- Flame-retardant and high strength
- Application temperature from -50°C to +170°C
- High temperature printer necessary
- Nozzle temperature: +350°C up to +360°C

▶ Page 726



Material:
iglidur® I180

Best combination of ability to be processed and service life

- Abrasion-resistant
- Good mechanical properties
- Nozzle temperature: +250°C up to +260°C
- Also in black (iglidur® I180-BL)

▶ Page 721



Material:
iglidur® J350

For high temperature applications

- Excellent coefficient of friction against steel
- Application temperature from -100°C to +180°C
- High temperature necessary of at least +160°C installation space temperature
- Nozzle temperature: +360°C up to +370°C

▶ Page 723



Material:
iglidur® C210

Resistant to chemicals and highly abrasion-resistant during printing

- High chemical resistance
- Abrasion-resistant
- High-quality processing
- Nozzle temperature: +260°C up to +270°C

▶ Page 725



Material:
iglidur® A350

For the food industry

- Compliant with Regulation (EU) No. 10/2011 and FDA guidelines
- Application temperature from -100°C to +180°C
- High temperature printer necessary
- Nozzle temperature: +360°C up to +370°C

▶ Page 727



3D print filament impresses during tests with injection moulding quality

Our iglidur® J260 tribo-filament is more wear-resistant than standard 3D printing materials. A series of igus® tests show: 3D printed plain bearings made from the filament iglidur® J260 are equally as wear-resistant as our injection-moulded parts from the same material. The tests have also proven that iglidur® 3D print filaments and SLS materials have a considerably lower coefficient of friction and are up to 50 times more abrasion-resistant than conventional 3D printing materials.

This makes iglidur® tribo-filaments and SLS materials the only 3D printing materials to also offer impressive performance in moving applications. You can therefore directly install printed parts such as plain bearings, drive nuts or worm gears and use them as wear-resistant parts – from the prototype phase to series production.

- Outstanding abrasion resistance of tribo-filaments
- Application temperature from -100°C to +120°C
- High-quality processing
- Available as filament, bar stock or injection-moulded part – **from prototype to series production**

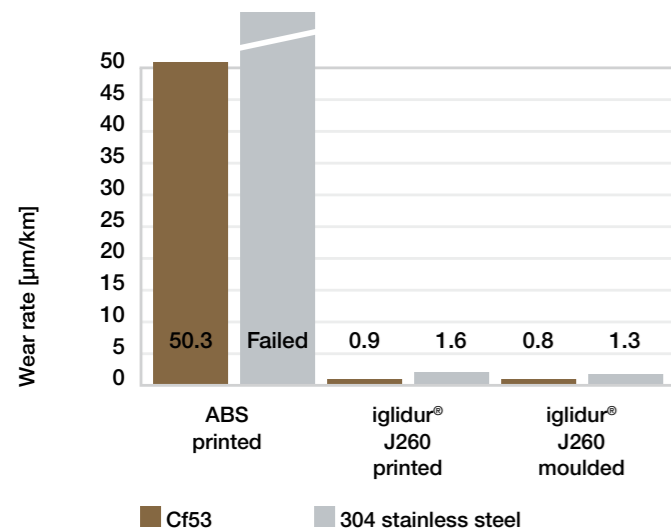

Rotating wear: p = 1MPa; v = 0.3m/s

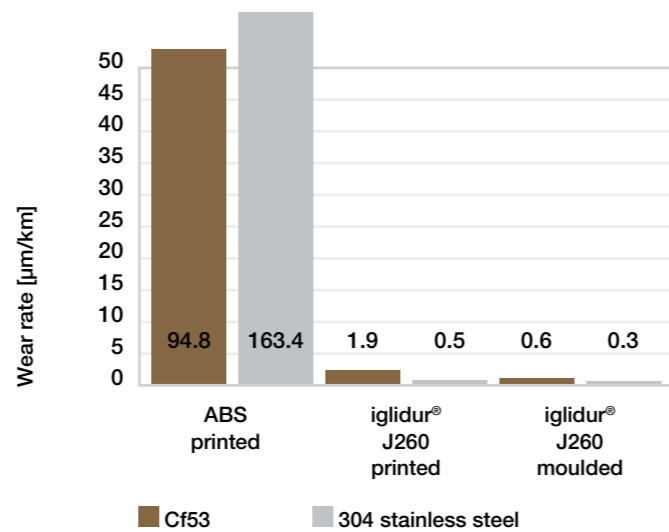

Linear wear: p = 1MPa; v = 0.3m/s; l = 5mm

Wear-resistant parts made of iglidur® tribo-filament with the 3D printing method or parts made of iglidur® I3 with the SLS method are much more wear-resistant than standard 3D printing materials.

The following tests also show "printed as good as injection-moulded": the 3D-printed iglidur® plain bearings are comparable to conventionally made plain bearings with respect to wear resistance.

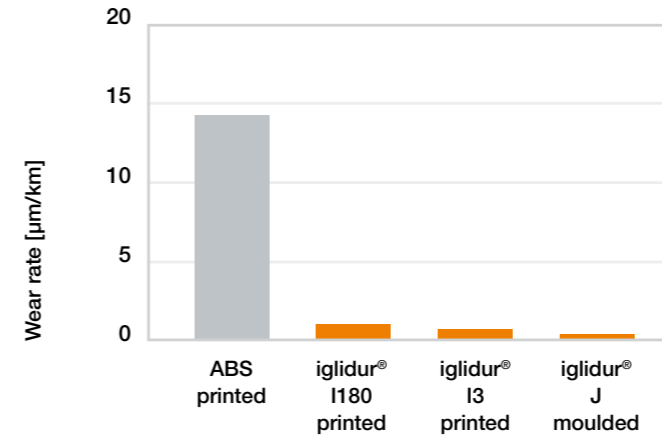

Linear wear: p = 0.11MPa; v = 0.34m/s; l = 370mm



ABS printed

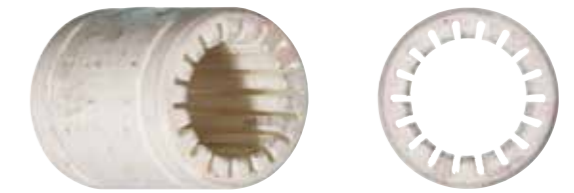

iglidur® I180 printed

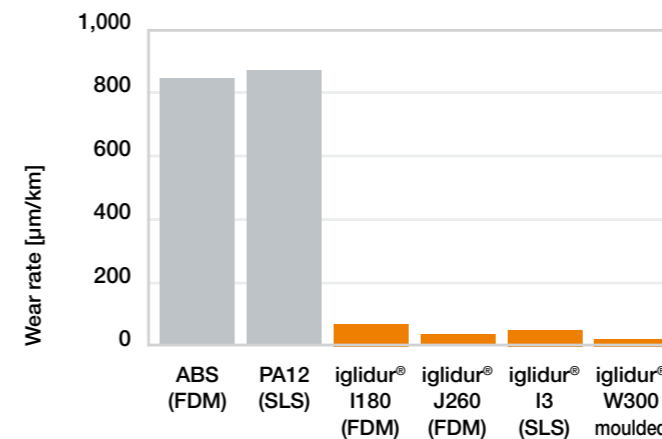

Wear, rotating p = 20 MPa; v = 0.01m/s, 304 stainless steel



ABS



PA12



iglidur® I3



iglidur® I180

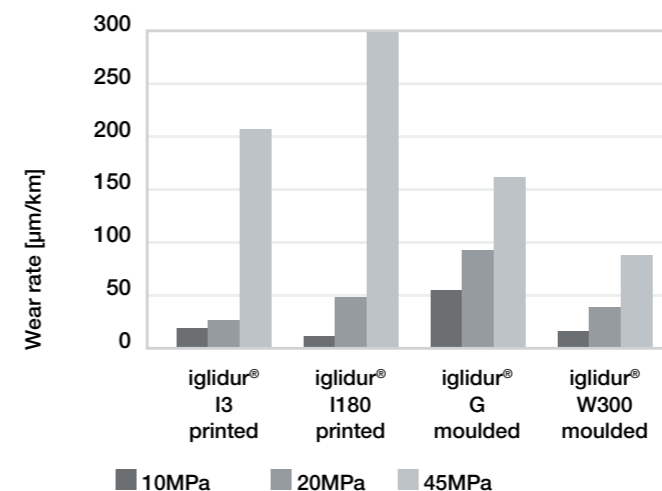

Wear, pivoting shaft: 304 stainless steel, v = 0.01m/s; β = 60°



iglidur® I3



iglidur® I180



iglidur® G



iglidur® W300



iglidur® I150



Order key

tribo-filament	Diameter	Weight
I150-PF-	0175	-0250
iglidur® material	tribo-filament	Ø [mm · 100]
		Spool weight [g]

iglidur® I150 – makes printing even easier

- High abrasion resistance at low speeds
- Good mechanical properties
- The tribo-filament that is easiest to process
- Compliant with food requirements according to (EU) No 10/2011
- Recommended printing surface: igus® adhesive film or glue-stick on glass
- Also to be processed without a heated print bed (prerequisite: igus® adhesive film ► **Page 728**)

Dimensions [mm]

Filament diameter	Outer Ø spool	Inner Ø spool	Spool width	Weight [g]	Part No.
1.75	205	55	55	250	I150-PF-0175-0250
1.75	205	55	67	750	I150-PF-0175-0750
3.00	205	55	55	250	I150-PF-0300-0250
3.00	205	55	67	750	I150-PF-0300-0750

Material properties

General properties	Unit	iglidur® I150	iglidur® I180	iglidur® I180-BL
Density	g/cm³	1.30	1.21	1.21
Colour		white	white	black
Max. moisture absorption at +23°C/50% r. h.	% weight	0.3	0.3	0.3
Max. total moisture absorption	% weight	0.7	0.9	0.9
Mechanical properties				
Flexural modulus	MPa	1,700	1,700	1,700
Flexural strength at +20°C	MPa	54/37 ¹³⁰⁾	46/33 ¹³⁰⁾	46/33 ¹³⁰⁾
Shore D hardness		62	66	66
Physical and thermal properties				
Max. long-term application temperature	°C	+65	+80	+80
Max. short-term application temperature	°C	+75	+90	+90
Min. continuous application temperature	°C	-30	-40	-40
Electrical properties				
Specific contact resistance	Ωcm	> 10 ¹³	> 10 ¹²	> 10 ¹²
Surface resistance	Ω	> 10 ¹²	> 10 ¹¹	> 10 ¹¹

Table 01: Material properties table

¹³⁰⁾ Printed flat/upright



iglidur® I180



Order key

tribo-filament	Diameter	Weight
I180-PF-	0175	-0250
iglidur® material	tribo-filament	Ø [mm · 100]
		Spool weight [g]



iglidur® I180-BL

iglidur® I180 – flexible

- High degree of abrasion resistance, even in the case of dynamic applications
- Good mechanical properties
- Max. application temperature: +80°C
- Recommended printing surface: igus® adhesive film ► **Page 728**

iglidur® I180-BL – for visible parts

- In black for visible parts
- Same mechanical and tribological properties as iglidur® I180 in white

Dimensions [mm]

Filament diameter	Outer Ø spool	Inner Ø spool	Spool width	Weight [g]	Part No.
1.75	205	55	55	250	I180-PF-0175-0250
1.75	205	55	67	750	I180-PF-0175-0750
3.00	205	55	55	250	I180-PF-0300-0250
3.00	205	55	67	750	I180-PF-0300-0750
1.75	205	55	55	250	I180-BL-PF-0175-0250
1.75	205	55	67	750	I180-BL-PF-0175-0750
3.00	205	55	55	250	I180-BL-PF-0300-0250
3.00	205	55	67	750	I180-BL-PF-0300-0750

Processing and accessories
► **Page 728**

Complete processing instructions online (in the download area of the respective material)
► www.igus.eu/tribofilament

Part No. adhesive film for print bed
PF-01-0203-0203 (203 x 203mm)
PF-01-0254-0228 (254 x 228mm)



iglidur® J260



Order key

tribo-filament	Diameter	Weight
J260-PF-	0175	-0250
iglidur® material	tribo-filament	Ø [mm · 100]
		Spool weight [g]

iglidur® J260 – extremely long service life

- Outstanding abrasion resistance of tribo-filaments
- Application temperature from -100°C to +120°C
- For experts: high-quality processing
- Recommended printing surface:
igus® adhesive film ► **Page 728**

Dimensions [mm]

Filament diameter	Outer Ø spool	Inner Ø spool	Spool width	Weight [g]	Part No.
1.75	205	55	55	250	J260-PF-0175-0250
1.75	205	55	67	750	J260-PF-0175-0750
3.00	205	55	55	250	J260-PF-0300-0250
3.00	205	55	67	750	J260-PF-0300-0750

Material properties

General properties	Unit	iglidur® J260	iglidur® J350
Density	g/cm³	1.35	1.44
Colour		Yellow	Yellow
Max. moisture absorption at +23°C/50% r. h.	% weight	0.2	0.3
Max. total moisture absorption	% weight	0.4	1.6
Mechanical properties			
Flexural modulus	MPa	1,000	1,400
Flexural strength at +20°C	MPa	41/13 ¹³⁰⁾	45/-
Shore D hardness		66	80
Physical and thermal properties			
Max. long-term application temperature	°C	+120	+180
Max. short-term application temperature	°C	+140	+220
Min. continuous application temperature	°C	-100	-100
Electrical properties			
Specific contact resistance	Ωcm	> 10 ¹²	> 10 ¹³
Surface resistance	Ω	> 10 ¹⁰	> 10 ¹⁰

Table 01: Material properties table

¹³⁰⁾ Printed flat/upright



iglidur® J350



Order key

tribo-filament	Diameter	Weight
J350-PF-	0175	-0250
iglidur® material	tribo-filament	Ø [mm · 100]
		Spool weight [g]

iglidur® J350 – for high temperature applications

- Max application temperature: +180°C
- Can be processed with high-temperature 3D printer
- Nozzle temperature: +360°C up to +370°C

- Installation area temperature: from +160°C to +200°C
- Recommended printing surface: PET film

Dimensions [mm]

Filament diameter	Outer Ø spool	Inner Ø spool	Spool width	Weight [g]	Part No.
1.75	205	55	55	250	J350-PF-0175-0250

Processing and accessories
► **Page 728**

Part No. adhesive film for print bed
PF-01-0203-0203 (203 x 203mm)
PF-01-0254-0228 (254 x 228mm)

Complete processing instructions online
(in the download area of the respective material)
► www.igus.eu/tribofilament



iglidur® I170



Order key

tribo-filament	Diameter	Weight
I170-PF-	0175	-0250
iglidur® material	tribo-filament	Ø [mm · 100]
		Spool weight [g]

iglidur® I170 – optimised service life

- Improved abrasion resistance
- Application temperature: +80°C
- For experts: high-quality processing
- Recommended printing surface:
igus® adhesive film ► **Page 728**

Dimensions [mm]

Filament diameter	Outer Ø spool	Inner Ø spool	Spool width	Weight [g]	Part No.
1.75	205	55	55	250	I170-PF-0175-0250
1.75	205	55	67	750	I170-PF-0175-0750
3.00	205	55	55	250	I170-PF-0300-0250
3.00	205	55	67	750	I170-PF-0300-0750

Material properties

General properties	Unit	iglidur® I170	iglidur® C210
Density	g/cm³	1.21	1.40
Colour		Yellow	white
Max. moisture absorption at +23°C/50% r. h.	% weight	0.5	0.3
Max. total moisture absorption	% weight	1.6	0.7
Mechanical properties			
Flexural modulus	MPa	1,000	1,600
Flexural strength at +20°C	MPa	33/17 ¹³⁰⁾	38/30 ¹³⁰⁾
Shore D hardness		64	70
Physical and thermal properties			
Max. long-term application temperature	°C	+75	+100
Max. short-term application temperature	°C	+85	+180
Min. continuous application temperature	°C	-40	-30
Electrical properties			
Specific contact resistance	Ωcm	> 10 ¹²	> 10 ¹³
Surface resistance	Ω	> 10 ¹¹	> 10 ¹²

Table 01: Material properties table

¹³⁰⁾ Printed flat/upright



iglidur® C210



Order key

tribo-filament	Diameter	Weight
C210-PF-	0175	-0250
iglidur® material	tribo-filament	Ø [mm · 100]
		Spool weight [g]

iglidur® C210 – chemicals and high abrasions resistance

- Resistance to many acids, solvents and hydrogen
- Abrasion-resistant
- Max application temperature: +100°C
- For experts: high-quality processing

- Recommended printing surface:
igus® adhesive film ► **Page 728**

Dimensions [mm]

Filament diameter	Outer Ø spool	Inner Ø spool	Spool width	Weight [g]	Part No.
1.75	205	55	55	250	C210-PF-0175-0250
3.00	205	55	55	250	C210-PF-0300-0250

Processing and accessories
► **Page 728**

Part No. adhesive film for print bed
PF-01-0203-0203 (203 x 203mm)
PF-01-0254-0228 (254 x 228mm)

Complete processing instructions online
(in the download area of the respective material)
► www.igus.eu/tribofilament



iglidur® RW370



Order key

tribo-filament	Diameter	Weight
RW370-PF-	0175	-0750
iglidur® material	tribo-filament	Ø [mm · 100]
		Spool weight [g]

iglidur® RW370 – ideal for the rail industry

- Flame-retardant, according to UL94-V0 and DIN EN 45545
- Flexural strength 91MPa
- High wear resistance
- Can be processed with high-temperature 3D printer
- Max application temperature: +170°C
- Available for 3D printing (Ø 1.75mm), as bar stock and as injection-moulding material
- Lubrication and maintenance-free
- Recommended printing surface: PET film

Dimensions [mm]

Filament diameter	Outer Ø spool	Inner Ø spool	Spool width	Weight [g]	Part No.
1.75	215	38	82	1,055	RW370-PF-0175-0750

Material properties

General properties	Unit	iglidur® RW370	iglidur® A350
Density	g/cm³	1.34	1.42
Colour		beige	blue
Max. moisture absorption at +23°C/50% r. h.	% weight	0.25	0.6
Max. total moisture absorption	% weight	1.2	1.9
Mechanical properties			
Flexural modulus	MPa	2,100	1.250/1.390 ¹³⁰⁾
Flexural strength at +20°C	MPa	91/30 ¹³⁰⁾	50/46 ¹³⁰⁾
Shore D hardness		80	76
Physical and thermal properties			
Max. long-term application temperature	°C	+170	+180
Max. short-term application temperature	°C	+190	+210
Min. continuous application temperature	°C	-50	-100
Electrical properties			
Specific contact resistance	Ωcm	> 10 ¹²	> 10 ¹¹
Surface resistance	Ω	> 10 ¹²	> 10 ¹¹

Table 01: Material properties table

¹³⁰⁾ Printed flat/upright



iglidur® A350



Order key

tribo-filament	Diameter	Weight
A350-PF-	0175	-0750
iglidur® material	tribo-filament	Ø [mm · 100]
		Spool weight [g]

iglidur® A350 – for the food industry

- Compliant with Regulation (EU) No. 10/2011 and FDA guidelines
- Available as 3D printing filament, bar stock and for injection moulding
- In industry standard blue
- Max. application temperature: +180°C
- Complies with the fire prevention requirements of the Federal Aviation Administration of the USA (FAA) for aircraft interiors
- Suitable for autoclave
- Recommended bonding surface: PET film

Dimensions [mm]

Filament diameter	Outer Ø spool	Inner Ø spool	Spool width	Weight [g]	Part No.
1.75	215	38	82	1,055	A350-PF-0175-0750

Processing and accessories
► Page 728

Complete processing instructions online
(in the download area of the respective material)
► www.igus.eu/tribofilament

Processing instructions

iglidur® tribo-filaments can be processed on any 3D printer that is equipped with a heated print bed on which temperatures are adjustable. The igus® adhesive film allows a good adhesion between the iglidur® tribo-filament and the print bed.

- Good ventilation should be provided during processing
- When heated above +300°C, hazardous fumes are produced
- For iglidur® J350, iglidur® A350, and iglidur® RW370, a high-temperature printer is necessary

igus® print bed film for your print bed

Thanks to the film available from igus® for the print bed, there is very good adhesion between the iglidur® tribo-filament and the print bed.

- Useable up to approximately 20 times
- "Set" the degree of adhesion by means of print bed temperature
- 3D printer without heating bed? The combination of iglidur® I150 with this print bed film also makes it possible to make wear-resistant parts oneself with such 3D printers

Spool

iglidur® tribo-filaments weighing 250g or 750g are wound onto a spool. Larger dimensions available upon request.

Filament thickness

The iglidur® tribo-filaments are available with 1.75mm and 3mm thickness. The 3mm filaments can be used without problems in 3D printers that need a 2.85mm filament.



Example: Part No. tribo-filaments

I150-PF-0175-0250

for 250g spool with a diameter of 1.75mm made of the iglidur® material I150



Complete processing instructions online (in the download area of the respective material)

▶ www.igus.eu/tribofilament



Part No. adhesive film for print bed

PF-01-0203-0203 (203 x 203mm)

PF-01-0254-0228 (254 x 228mm)



Test kits

for 25g of filament, loose with 1.75mm diameter made of the iglidur® material I150

