

## igubal<sup>®</sup> rod end bearings

Maintenance-free dry operation

Robust

Durable

Compensation of misalignment errors

Resistant to edge loads

Lightweight



igubal® rod ends can also be used in rough environments. They are corrosion-resistant in humid environments and resistant to weak acids and media. Depending on the version (HT) the operation temperature is from -40°C to +200°C. Rod ends are also resistant to dirt and dust, they are also available as detectable version.

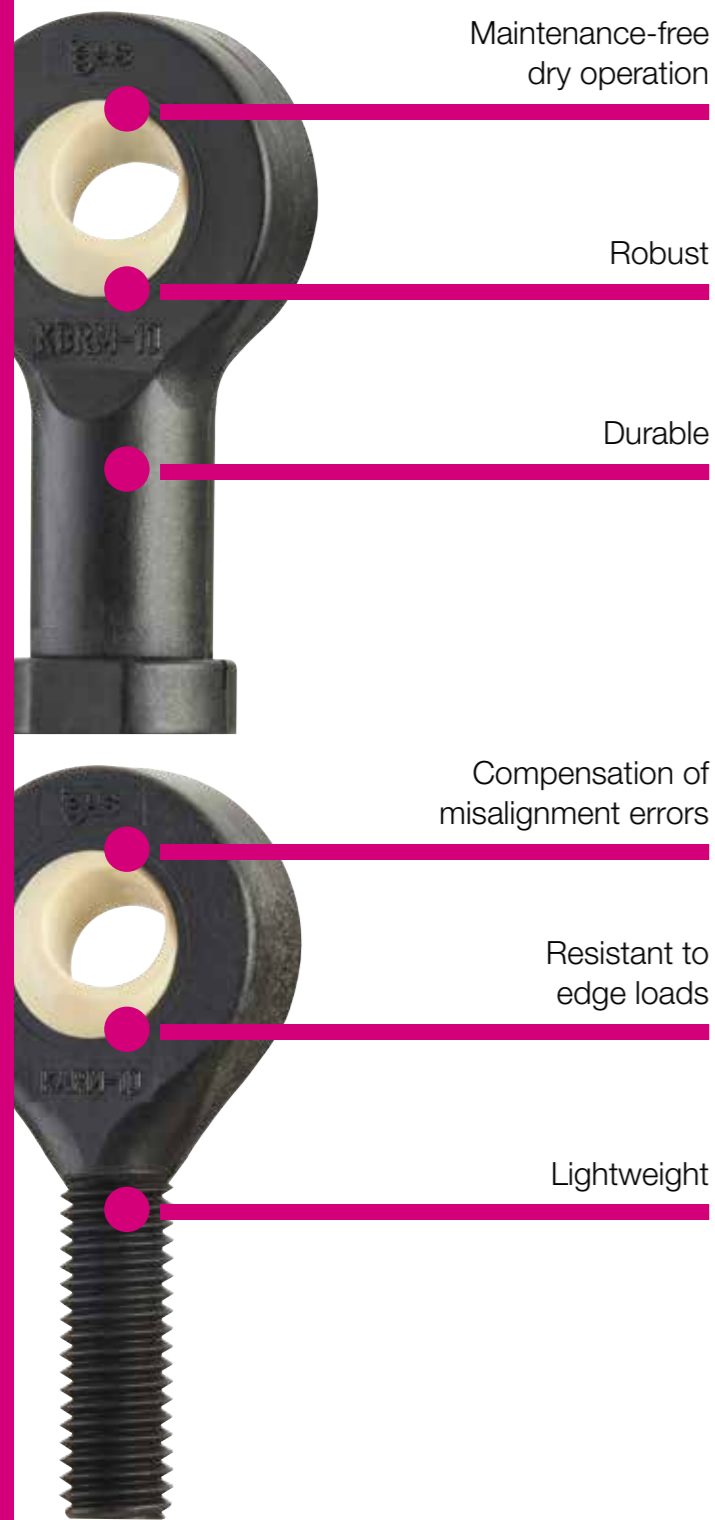

### When to use it?

- If you want to save weight
- For rotating, oscillating and linear movements
- If high-frequency oscillations/vibrations occur
- If silent operation is required
- If you need an electrically insulating part
- If corrosion resistance is required
- In combination with pneumatic cylinders and gas struts
- If chemical resistance is required
- If high rigidity is required
- If they should be detectable



### When not to use it?

- When temperatures are higher than +80°C  
▶ HT version, page 760–761
- When rotation speeds higher than 0.5m/s are required
- When really high tensile and axial forces occur
- With a hydraulic cylinder
- When dimensions above 30mm are required



**Max. + 200°C**  
**Min. -40°C**

(depending on material: standard from -30°C to +80°C; HT from -40°C to +200°C)



**18 types**  
**Ø 2–30mm**



**Imperial dimensions available**  
▶ From page 1606



**Online product finder**  
▶ [www.igus.eu/igubal-finder](http://www.igus.eu/igubal-finder)



### Available from stock

Detailed information about delivery time online.



### Price breaks online

No minimum order value. No minimum order quantity



### Typical sectors of industry and application areas

- Bicycle manufacturing
- Plant design
- Packaging
- Offshore etc.

Improve technology and reduce costs – 110 exciting examples online

▶ [www.igus.eu/igubal-applications](http://www.igus.eu/igubal-applications)



▶ [www.igus.eu/special-bikes](http://www.igus.eu/special-bikes)



▶ [www.igus.eu/textile](http://www.igus.eu/textile)



▶ [www.igus.eu/packaging](http://www.igus.eu/packaging)



▶ [www.igus.eu/offshore](http://www.igus.eu/offshore)

**Advantages**

- Maintenance-free dry operation
- Robust
- Durable in varying loads
- Compensation of misalignment errors
- Resistant to edge loads
- Resistant to dirt, dust and lint
- Resistant to corrosion and chemicals
- Vibration-dampening
- Suitable for rotating, oscillating and linear movements
- Lightweight
- Dimensional K and E series, according to standard DIN ISO 12240
- Available with stainless steel sleeve for higher tightening torque

**Product range**

igubal® rod ends are available in the dimensional K and E series for shaft diameters of 2 to 30mm according to standard DIN ISO 12240

- Form A – with male thread and
- Form B – with female thread

**Stainless steel sleeve**

The dimensional K and partially E series are available in imperial dimensions, as well as a special version containing a stainless steel sleeve in the spherical ball. This allows a significantly higher tightening torque than for the standard polymer race. Please ask us for more dimensions.

**Loads**

igubal® rod ends handle high loads at ambient temperatures, have excellent dampening properties and weigh only a fifth of traditional metallic bearing housings. In applications with high continuous loads and high temperatures, the load capacity of igubal® rod ends should be tested in an experiment that simulates the application.

► [www.igus.eu/igubal-finder](http://www.igus.eu/igubal-finder)

**Coefficient of sliding friction and speed**

Rotary movements of a mounted shaft take place directly in the spherical portion, made from iglidur® W300. The advantage therefore lies in the polymer vs. steel relationship. Polymer produces lower friction and permits high speeds, even in dry operation. Taking the radial loads into account, maximum surface speeds up to 0.5m/s rotating can be attained.

The maintenance-free igubal® rod end bearings permit linear and oscillating movements of the shaft.

**Temperatures**

The igubal® rod ends can be used in temperatures from -30°C up to +80°C. The igubal® rod ends made from HT material are suitable for temperatures up to +200°C (E series, female and male threads).

**Tolerances**

igubal® rod ends can be used at different tolerances depending on the individual application. They are designed with a large clearance in the standard product, which enables a secure operation even under high peripheral speeds. The hole of the spherical ball is produced to a standard tolerance range E10. Shafts should also meet recommended tolerances h6 and h9. All values and tolerances according to ISO 2768-m. Please contact us in case you require lower or other bearing tolerances.

**Pivot angle**

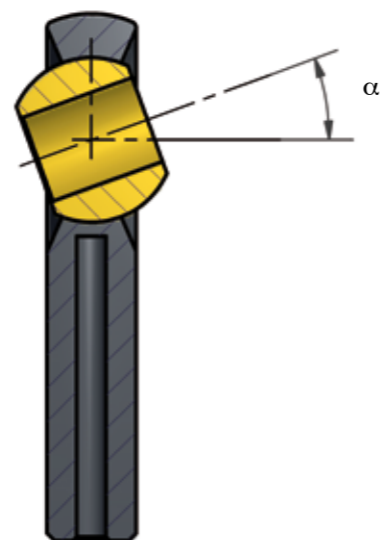

**igubal® rod end bearings with female thread**

					
<b>Classic design</b>	<b>Easy assembly</b>	<b>Selectable spherical ball material</b>	<b>Space-saving</b>	<b>For temperatures up to +200°C</b>	<b>Suitable for food contact</b>
K series	K series	K series	E series	E series	E series
► From page 746	► Page 748	► Page 750	► Page 756	► Page 760	► Page 762

**igubal® rod end bearings with male thread**

						
<b>Classic design, imperial dimensions</b>	<b>Space-saving, imperial dimensions</b>	<b>Classic design</b>	<b>Higher forces</b>	<b>Space-saving</b>	<b>For temperatures up to +200°C</b>	<b>Classic design, imperial dimensions</b>
K series	E series	K series	K series	E series	E series	K series
► Page 1608	► Page 1606	► From page 752	► Page 754	► From page 758	► Page 761	► From page 1607

**igubal® angled and in-line ball and socket joints**

				
<b>Angled ball and socket joints</b>	<b>Angled ball and socket joints, low-cost</b>	<b>Easy assembly and disassembly</b>	<b>In-line ball and socket joints</b>	<b>In-line ball and socket joints, low-cost</b>
► Page 764	► Page 765	► Page 766	► Page 767	► Page 768

**igubal® accessories for rod ends**

		
<b>Clevis joints with clevis pin and circlip</b>	<b>Clevis joints with spring-loaded fixing clip</b>	<b>Detectable rod ends and clevis joints</b>
E series	E series	
► Page 778	► Page 779	► From page 863

Rod ends with female thread: KBRM and KBLM



Standard design

Stainless steel sleeve version (MH)

- Maintenance-free dry operation
  - Robust
  - Durable in varying loads
  - Compensation of misalignment errors
  - Resistant to edge loads
  - Resistant to dirt, dust and lint
  - Resistant to corrosion and chemicals
  - Vibration-dampening
  - Suitable for rotating, oscillating and linear movements
  - Lightweight
  - Dimensional K series according to DIN ISO 12240
  - Available with stainless steel sleeve for higher tightening torque
  - Adapter screw with circlip available
- ▶ Accessories, page 861

Service life calculation online  
▶ [www.igus.eu/igubal-expert](http://www.igus.eu/igubal-expert)

Technical data

Part No.	Max. static tensile strain		Max. static axial load		Min. thread depth	Max. tightening torque	Max. tightening torque through ball		Weight
	Short-term	Long-term	Short-term	Long-term			without stainless steel sleeve	with stainless steel sleeve	
KB□M-02	200	100	50	25	4	0.30	1	–	0.4
KB□M-03	800	400	100	50	5	0.50	2	4	2.7
KB□M-05 M4	1,000	500	250	125	7	0.75	5	12	3.5
KB□M-05	1,000	500	250	125	7	1.00	5	12	3.4
KB□M-06	1,400	700	400	200	8	1.50	10	15	4.7
KB□M-08	2,100	1,050	700	350	11	5.00	12	40	8.6
KB□M-10	3,100	1,550	800	400	13	15.00	20	50	14.6
KB□M-10 F	3,100	1,550	800	400	13	6.00	20	50	14.6
KB□M-12 <sup>129)</sup>	3,600	1,800	900	450	15	20.00	30	70	22.0
KB□M-12 F	3,600	1,800	900	450	15	15.00	30	70	22.0
KB□M-14	4,000	2,000	1,000	500	17	25.00	35	75	30.9
KB□M-16	4,200	2,100	1,300	650	19	30.00	40	110	39.6
KB□M-16 F	4,200	2,100	1,300	650	19	27.50	40	110	39.6
KB□M-18	4,600	2,300	1,600	800	21	45.00	45	150	55.0
KB□M-20	5,400	2,700	2,100	1,050	22	60.00	55	200	73.5
KB□M-20 M20	5,400	2,700	2,100	1,050	22	60.00	55	200	73.5
KB□M-22	7,000	3,500	2,200	1,100	25	75.00	60	–	94.8
KB□M-25	8,500	4,250	2,300	1,150	28	120.00	60	–	119.8
KB□M-30	10,500	5,250	2,500	1,250	34	135.00	60	–	177.0
KB□M-30 M27x2	10,500	5,250	2,500	1,250	34	135.00	60	–	189.6

<sup>129)</sup> Integrated lock nut. Drawing as for KCRM, page 751

Rod ends with female thread: KBRM and KBLM

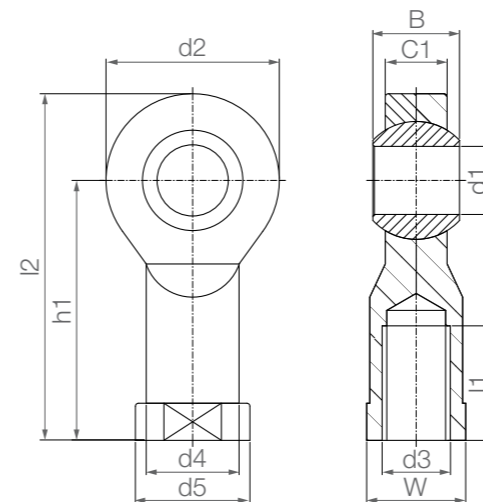

Order key

Type	Size [mm]	Options
<b>K B □ M - 02 MH</b>		Thread L = Left-hand thread R = Right-hand thread
<b>K series</b>		Add-on: MH = With stainless steel sleeve
<b>Housing (female thread)</b>		
<b>Thread</b>		
<b>Metric</b>		
<b>Inner Ø</b>		

**Material:**  
Housing: igumid G ▶ Page 1654  
Spherical ball: iglidur® W300 ▶ Page 171

Imperial dimensions available  
▶ Page 1608

Dimensions [mm]

Part No.	d1	d2	d3	d4	d5	C1	B		h1	l1	l2	W	Max. pivot angle
							without stainless steel sleeve	with stainless steel sleeve					
	E10												
								+0.2					
KB□M-02	2	9	M2	4.0	4.6	3.0	4	–	12.5	6	17	SW4	30°
KB□M-03	3	13	M3	6.5	8.0	4.5	6	6.2	18.5	8	25	SW6	30°
KB□M-05 M4	5	18	M4	9.0	12.0	6.0	8	8.2	27	10	36	SW9	30°
KB□M-05	5	18	M5	9.0	12.0	6.0	8	8.2	27	10	36	SW9	30°
KB□M-06	6	20	M6	10.0	13.0	7.0	9	9.2	30	12	40	SW11	29°
KB□M-08	8	24	M8	13.0	16.0	9.0	12	12.2	36	16	48	SW14	25°
KB□M-10	10	30	M10	15.0	19.0	10.5	14	14.2	43	20	58	SW17	25°
KB□M-10 F	10	30	M10 x 1.25	15.0	19.0	10.5	14	14.2	43	20	58	SW17	25°
KB□M-12	12	34	M12	–	–	12.0	16	16.2	50	25	67	SW17	25°
KB□M-12 F	12	34	M12 x 1.25	18.0	22.0	12.0	16	16.2	50	22	67	SW19	25°
KB□M-14	14	38	M14	20.0	25.0	13.5	19	19.2	57	25	76	SW22	25°
KB□M-16	16	42	M16	22.0	27.0	15.0	21	21.2	64	28	85	SW22	23°
KB□M-16 F	16	42	M16 x 1.5	22.0	27.0	15.0	21	21.2	64	28	85	SW22	23°
KB□M-18	18	46	M18 x 1.5	25.0	31.0	16.5	23	23.2	71	32	94	SW27	23°
KB□M-20	20	50	M20 x 1.5	28.0	34.0	18.0	25	25.2	77	33	102	SW30	23°
KB□M-20 M20	20	50	M20 x 2.5	28.0	34.0	18.0	25	25.2	77	33	102	SW30	23°
KB□M-22	22	56	M22 x 1.5	30.0	37.0	20.0	28	–	84	37	112	SW32	22°
KB□M-25	25	60	M24 x 2.0	32.0	41.0	22.0	31	–	94	42	124	SW36	22°
KB□M-30	30	70	M30 x 2.0	37.0	50.0	25.0	37	–	110	50	145	SW41	22°
KB□M-30 M27x2	30	70	M27 x 2.0	37.0	50.0	25.0	37	–	110	50	145	SW41	22°

Rod ends can be ordered in metric dimensions with stainless steel sleeve with the addition of MH after the part numbers listed here. Example: KBRM-10 MH (Inner Ø: 10mm).

Rod ends, female thread; 2nd generation: KBRM CL and KBLM CL



- Available with stainless steel sleeve for higher tightening torque
- Dimensional K series according to DIN ISO 12240
- Adapter screw with circlip available  
▶ Accessories, page 861



Simple assembly due to the hexagonal body and the integrated lock nut

Service life calculation online  
▶ [www.igus.eu/igubal-expert](http://www.igus.eu/igubal-expert)

Technical data

Part No.	Max. static tensile strain		Max. static axial force		Min. thread depth Thread [mm]	Max. tightening torque Female thread [Nm]	Max. tightening torque through ball		Weight [g]	
	Short-term [N]	Long-term [N]	Short-term [N]	Long-term [N]			without stainless steel sleeve [Nm]	with stainless steel sleeve [Nm]		
										Max. pivot angle
<b>KB□M-06 CL</b>	1,400	700	300	150	8	0.75	10	15	4.5	40°
<b>KB□M-08 CL</b>	2,100	1,050	500	250	11	2	12	40	8.6	35°
<b>KB□M-10 CL</b>	3,100	1,550	800	400	13	3	20	50	14.1	35°

Alternative spherical ball materials ▶ Page 841



Rod ends, female thread; 2nd generation: KBRM CL and KBLM CL

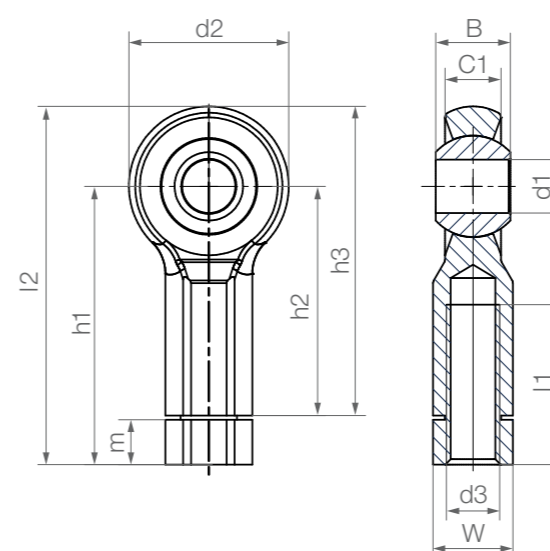

Order key

Type	Size [mm]	Version
<b>K B □ M - 06 CL MH</b>		
<b>K series</b>		
<b>Housing (female thread)</b>		
<b>Thread</b>		
<b>Metric</b>		
<b>Inner Ø</b>		
<b>2nd generation</b>		

Options: Thread L = Left-hand thread R = Right-hand thread  
Add-on: MH = With stainless steel sleeve

Material: Housing: **igumid G** ▶ Page 1654  
Spherical ball: **iglidur® W300** ▶ Page 171  
Other spherical ball materials upon request  
▶ Page 841

Dimensions [mm]

Part No.	d1 E10	d2	d3	W	B		C1	h3	h1	h2	l1	l2	m	Max. pivot angle
					without stainless steel sleeve	with stainless steel sleeve +0.2								
<b>KB□M-06 CL</b>	6	20	M6	SW10	9	9.2	7	40	36.5	30	20	46.5	5.7	40°
<b>KB□M-08 CL</b>	8	24	M8	SW13	12	12.2	9	48	44.3	36	25	56.3	7.5	35°
<b>KB□M-10 CL</b>	10	30	M10	SW15	14	14.2	10.5	58	52.2	43	30	67.2	8.4	35°

Rod ends can be ordered in metric dimensions with stainless steel sleeve with the addition of **MH** after the part numbers listed here. Example: KBRM-10 CL **MH** (Inner Ø: 10mm).

For another spherical bearing material than iglidur® W300, please add "J" to the part number, for example. Example: KBRM-10 CL **J**.

Rod ends with female thread: KCRM and KCLM



- Smooth design no dirt traps
- Spherical ball is clipped in
- Choice of iglidur® spherical ball materials
- Compensation of misalignment errors
- Lightweight
- Absolute corrosion resistance
- Available with stainless steel sleeve for higher tightening torque
- Dimensional K series according to DIN ISO 12240
- Adapter screw with circlip available
- ▶ Accessories, page 861

Service life calculation online  
▶ [www.igus.eu/igubal-expert](http://www.igus.eu/igubal-expert)

Technical data

Part No.	Max. static tensile strain		Max. static axial force		Min. thread depth	Max. tightening torque	Max. tightening torque through ball		Weight	
	Short-term	Long-term	Short-term	Long-term			without stainless steel sleeve	with stainless steel sleeve		Max. pivot angle
KC□M-05	1,200	600	180	90	7	1.00	5	12	4.0	
KC□M-06	1,400	700	300	150	8	0.75	10	15	4.2	
KC□M-08	2,100	1,050	500	250	11	2.00	12	40	7.6	
KC□M-10	3,100	1,550	800	400	13	3.00	20	50	12.8	
KC□M-10-F	3,100	1,550	800	400	13	3.00	20	50	12.8	
KC□M-12	3,560	1,780	750	375	15	15.0	30	70	19.0	
KC□M-12-F	3,560	1,780	750	375	15	15.0	30	70	19.0	
KC□M-16	3,800	1,900	800	400	19	15.0	40	110	34.0	
KC□M-16-F	3,800	1,900	800	400	19	15.0	40	110	34.0	
KC□M-20	4,550	2,275	400	200	22	20.0	55	200	55.0	
KC□M-20-M20	4,550	2,275	400	200	22	20.0	55	200	55.0	

Alternative spherical ball materials ▶ Page 841



Rod ends with female thread: KCRM and KCLM

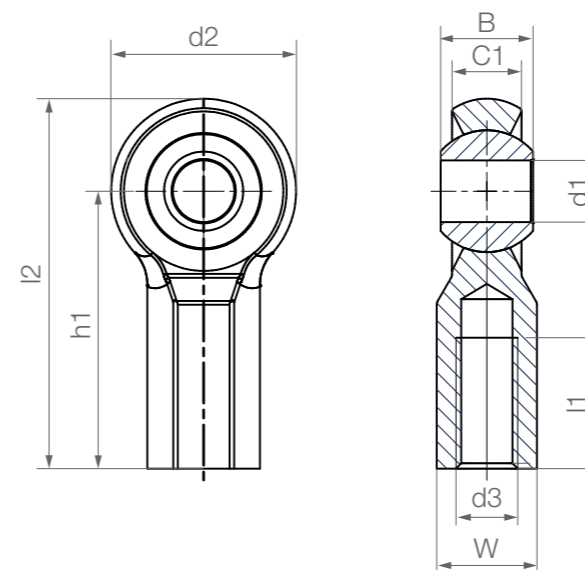

Order key

Type	Size [mm]	Options
K C □ M - 06		MH
K series		Thread
Housing (female thread)		L = Left-hand thread R = Right-hand thread
Thread		Add-on:
Metric		MH = With stainless steel sleeve
Inner Ø		

Material:  
Housing: igumid G ▶ Page 1654  
Spherical ball: iglidur® W300 ▶ Page 171  
Other spherical ball materials upon request  
▶ Page 841

Dimensions [mm]

Part No.	d1 E10	d2	d3	W	B		C1	h1	I1	I2	Max. pivot angle
					without stainless steel sleeve	with stainless steel sleeve +0.2					
KC□M-05	5	18	M5	SW9	8	8.2	6.0	27	12.0	36	43°
KC□M-06	6	20	M6	SW10	9	9.2	7.0	30	13.5	40	40°
KC□M-08	8	24	M8	SW13	12	12.2	9.0	36	17.0	48	35°
KC□M-10	10	30	M10	SW15	14	14.2	10.5	43	22.0	58	35°
KC□M-10-F	10	30	M10 x 1.25	SW15	14	14.2	10.5	43	22.0	58	35°
KC□M-12	12	34	M12	SW17	16	16.2	12.0	50	25.0	67	35°
KC□M-12-F	12	34	M12 x 1.25	SW17	16	16.2	12.0	50	25.0	67	35°
KC□M-16	16	42	M16	SW20	21	21.2	15.0	64	30.0	85	35°
KC□M-16-F	16	42	M16 x 1.5	SW20	21	21.2	15.0	64	30.0	85	35°
KC□M-20	20	50	M20 x 1.5	SW24	25	25.2	18.0	77	35.0	102	35°
KC□M-20-M20	20	50	M20 x 2.5	SW24	25	25.2	18.0	77	35.0	102	35°

Rod ends can be ordered in metric dimensions **with stainless steel** sleeve with the addition of **MH** after the part numbers listed here. Example: KCRM-10 **MH** (Inner Ø: 10mm).

For another spherical bearing material than iglidur® W300, please add "J" to the part number, for example. Example: KCRM-05 J.

Rod ends with male thread: KARM and KALM



Standard design

Stainless steel sleeve version (MH)

- Maintenance-free dry operation
  - Robust
  - Durable in varying loads
  - Compensation of misalignment errors
  - Resistant to edge loads
  - Resistant to dirt, dust and lint
  - Resistant to corrosion and chemicals
  - Vibration-dampening
  - Suitable for rotating, oscillating and linear movements
  - Lightweight
  - Dimensional K series according to DIN ISO 12240
  - Available with stainless steel sleeve for higher tightening torque
  - Adapter screw with circlip available
- Accessories, page 861

Service life calculation online  
► [www.igus.eu/igubal-expert](http://www.igus.eu/igubal-expert)

Technical data

Part No.	Max. static tensile strain		Max. static axial force		Min. thread depth Thread [mm]	Max. tightening torque Male thread [Nm]	Max. tightening torque through ball		Weight [g]
	Short-term [N]	Long-term [N]	Short-term [N]	Long-term [N]			Without stainless steel sleeve [Nm]	With stainless steel sleeve [Nm]	
KA□M-05	800	400	80	40	13	0.4	5	12	2.7
KA□M-06	1,000	500	100	50	15	0.5	10	15	3.9
KA□M-08	1,700	850	200	100	18	2.0	12	40	7.1
KA□M-10	2,500	1,250	300	150	20	5.0	20	50	12.5
KA□M-10 F	2,500	1,250	300	150	20	3.0	20	50	12.5
KA□M-12	2,700	1,350	400	200	22	6.0	30	70	18.0
KA□M-12 F	2,700	1,350	400	200	22	6.0	30	70	18.0
KA□M-14	3,400	1,700	700	350	25	12.0	35	75	25.0
KA□M-16	3,900	1,950	800	400	26	17.0	40	110	34.0
KA□M-16 F	3,900	1,950	800	400	26	17.0	40	110	34.0
KA□M-18	4,200	2,100	1,000	500	29	20.0	45	150	45.9
KA□M-20	6,000	3,000	1,300	650	32	25.0	55	200	58.0
KA□M-20 M20	6,000	3,000	1,300	650	32	25.0	55	200	58.0
KA□M-22	7,200	3,600	1,500	750	34	25.0	60	-	86.2
KA□M-25	7,500	3,750	1,900	950	39	45.0	65	-	99.1
KA□M-30	8,800	4,400	2,300	1,150	46	85.0	70	-	160.4

Rod ends with male thread:  
KARM and KALM

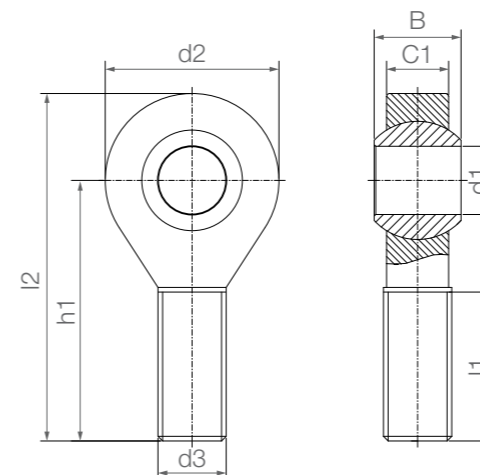

Order key

Type	Size [mm]	Options
<b>K A □ M - 05</b>		<b>MH</b>
<b>K series</b>		Thread L = Left-hand thread R = Right-hand thread
<b>Housing (male thread)</b>		Add-on: MH = With stainless steel sleeve
<b>Thread</b>		
<b>Metric</b>		
<b>Inner Ø</b>		

**Material:**  
Housing: igumid G ► Page 1654  
Spherical ball: iglidur® W300 ► Page 171

Imperial dimensions available  
► Page 1607

Dimensions [mm]

Part No.	d1 E10	d2	d3	C1	B		h1	l1	l2	Max. pivot angle
					without stainless steel sleeve	with stainless steel sleeve +0.2				
KA□M-05	5	18	M5	6.0	8	8.2	33	19	42	30°
KA□M-06	6	20	M6	7.0	9	9.2	36	21	46	29°
KA□M-08	8	24	M8	9.0	12	12.2	42	25	55	25°
KA□M-10	10	30	M10	10.5	14	14.2	48	28	63	25°
KA□M-10 F	10	30	M10 x 1.25	10.5	14	14.2	48	28	63	25°
KA□M-12	12	34	M12	12.0	16	16.2	54	32	71	25°
KA□M-12 F	12	34	M12 x 1.25	12.0	16	16.2	54	32	71	25°
KA□M-14	14	38	M14	13.5	19	19.2	61	36	79	25°
KA□M-16	16	42	M16	15.0	21	21.2	66	37	88	23°
KA□M-16 F	16	42	M16 x 1.5	15.0	21	21.2	66	37	88	23°
KA□M-18	18	46	M18 x 1.5	16.5	23	23.2	72	41	96	23°
KA□M-20	20	50	M20 x 1.5	18.0	25	25.2	78	45	104	23°
KA□M-20 M20	20	50	M20 x 2.5	18.0	25	25.2	78	45	104	23°
KA□M-22	22	56	M22 x 1.5	20.0	28	-	84	48	112	22°
KA□M-25	25	61	M24 x 2.0	22.0	31	-	95	55	126	22°
KA□M-30	30	71	M30 x 2.0	25.0	37	-	112	66	147	22°

Rod ends can be ordered in metric dimensions **with stainless steel** sleeve with the addition of **MH** after the part numbers listed here. Example: KARM-10 **MH** (Inner Ø: 10mm).

Rod ends, male thread; 2nd generation:  
KARM CL

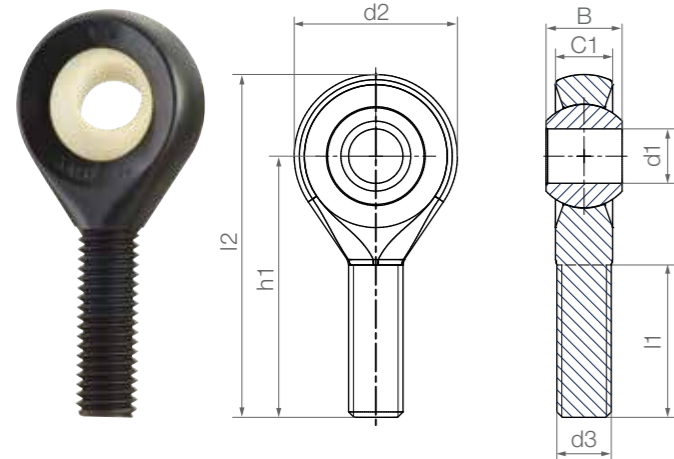

Order key

Type	Size [mm]	Version
<b>K</b>	<b>A</b>	<b>M-06</b>
<b>CL</b>		<b>MH</b>
<b>K series</b>	<b>Housing (male thread)</b>	<b>Thread</b>
	<b>Thread</b>	<b>Metric</b>
	<b>Inner Ø</b>	<b>2nd generation</b>
		<b>Thread</b>
		<b>L =</b>
		<b>Left-hand thread</b>
		<b>R =</b>
		<b>Right-hand thread</b>
		<b>Add-on:</b>
		<b>MH =</b>
		<b>With stainless steel sleeve</b>

**Material:**  
 Housing: **igumid G** ▶ **Page 1654**  
 Spherical ball: **iglidur® W300** ▶ **Page 171**  
 Other spherical ball materials upon request  
 ▶ **Page 841**

- Smooth design no dirt traps
- Compensation of misalignment errors
- Lightweight
- Absolute corrosion resistance
- Available with stainless steel sleeve for higher tightening torque
- Dimensional K series according to DIN ISO 12240
- Adapter screw with circlip available  
▶ Accessories, **page 861**

Technical data

Part No.	Max. static tensile strain		Max. static axial force		Min. thread depth	Max. tightening torque	Max. tightening torque through ball		Weight
	Short-term	Long-term	Short-term	Long-term			without stainless steel sleeve	with stainless steel sleeve	
<b>KA□M-06 CL</b>	1,000	500	100	50	15	0.5	10	15	3.5
<b>KA□M-08 CL</b>	1,700	850	200	100	18	2.0	12	40	6.2
<b>KA□M-10 CL</b>	2,500	1,250	300	150	20	5.0	20	50	11.2
<b>KA□M-12 CL</b>	2,700	1,350	400	200	22	6.0	30	70	15.6

Dimensions [mm]

Part No.	d1 E10	d2	d3	C1	B		h1	l1	l2	Max. pivot angle
					without stainless steel sleeve	with stainless steel sleeve +0.2				
<b>KA□M-06 CL</b>	6	20	M6	7.0	9	9.2	36	21	46	40°
<b>KA□M-08 CL</b>	8	24	M8	9.0	12	12.2	42	25	55	35°
<b>KA□M-10 CL</b>	10	30	M10	10.5	14	14.2	48	28	63	35°
<b>KA□M-12 CL</b>	12	34	M12	12.0	16	16.2	54	32	71	35°

Rod ends can be ordered in metric dimensions with stainless steel sleeve with the addition of **MH** after the part numbers listed here. Example: **KARM-10 CL MH (Inner Ø: 10mm)**.

For another spherical bearing material than iglidur® W300, please add "**J**" to the part number, for example. Example: **KARM-10 CL J**.

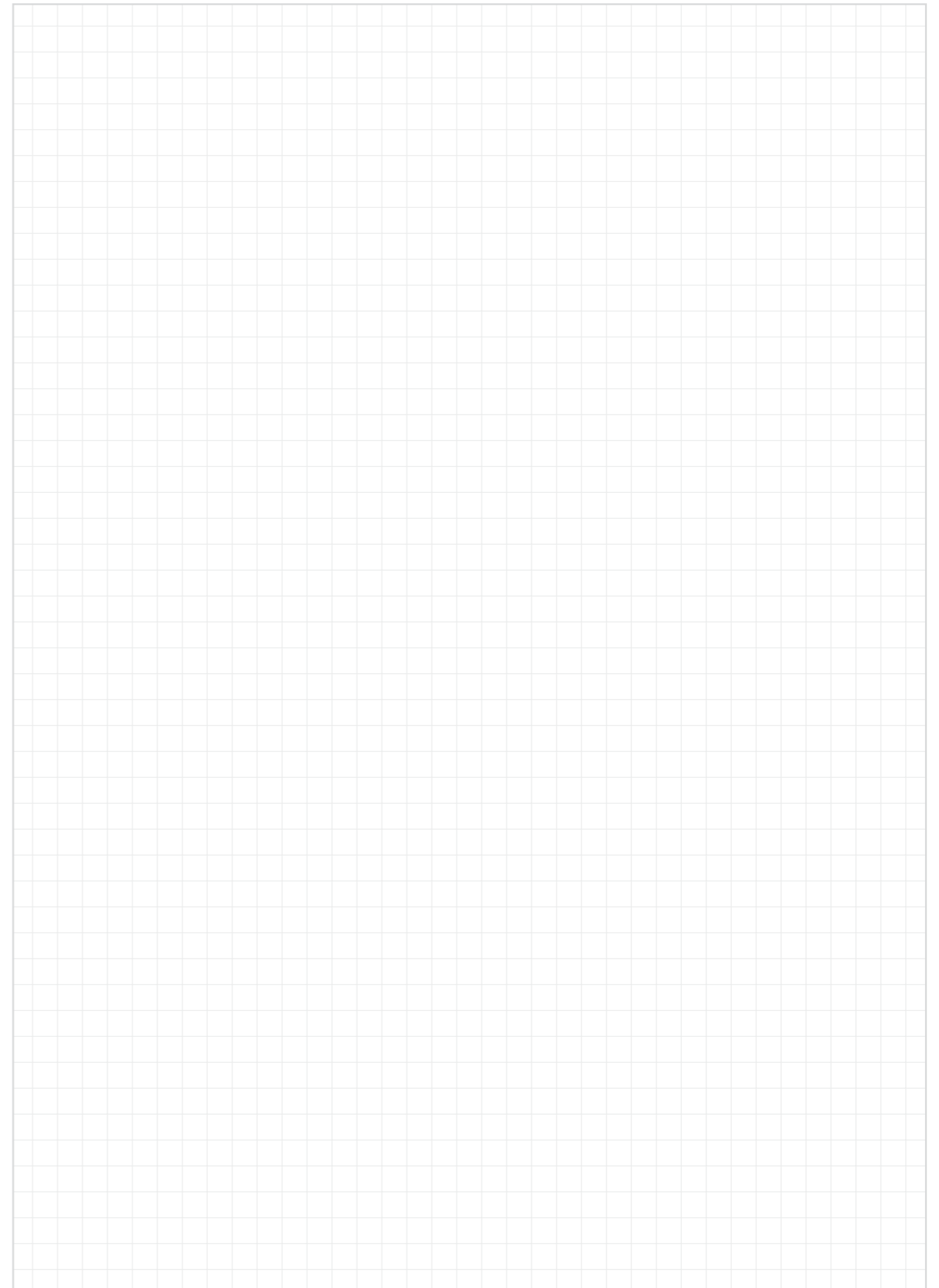



Rod ends with female thread: EBRM and EBLM



- Maintenance-free dry operation
- Robust
- Durable in varying loads
- Compensation of misalignment errors
- Resistant to edge loads
- Resistant to dirt, dust and lint
- Resistant to corrosion and chemicals
- Vibration-dampening
- Suitable for rotating, oscillating and linear movements
- Lightweight
- Dimensional E series according to DIN ISO 12240
- For temperatures up to +200°C we recommend EBRM-HT and EBLM-HT ▶ Page 760
- Detectable version ▶ Page 867

Service life calculation online  
▶ [www.igus.eu/igubal-expert](http://www.igus.eu/igubal-expert)

Technical data

Part No.	Max. static tensile strain		Max. static axial force		Min. thread depth Thread [mm]	Max. tightening torque Female thread [Nm]	Max. tightening torque through ball [Nm]	Weight [g]
	Short-term	Long-term	Short-term	Long-term				
	[N]	[N]	[N]	[N]				
EB□M-04	800	400	100	50	7	0.4	2.0	1.8
EB□M-05	1,300	650	150	75	8	0.5	2.0	3.2
EB□M-06	1,500	750	200	100	8	1.5	2.5	4.0
EB□M-08	2,000	1,000	450	225	11	5.0	7.0	6.9
EB□M-10	2,300	1,150	500	250	13	15.0	14.0	11.2
EB□M-10 F	2,300	1,150	500	250	13	6.0	14.0	11.2
EB□M-12	3,300	1,650	550	275	14	20.0	25.0	17.1
EB□M-12 F	3,300	1,650	550	275	14	15.0	25.0	17.1
EB□M-15	4,800	2,400	800	400	18	25.0	30.0	28.9
EB□M-16	5,000	2,500	850	425	18	20.0	32.0	32.6
EB□M-16 F	5,000	2,500	850	425	18	15.0	32.0	32.6
EB□M-17	5,300	2,650	1,100	550	19	30.0	35.0	42.4
EB□M-17 F	5,300	2,650	1,100	550	19	27.5	35.0	42.4
EB□M-20	7,200	3,600	1,800	900	22	60.0	40.0	65.8
EB□M-20 M20	7,200	3,600	1,800	900	22	60.0	40.0	65.8
EB□M-25	10,000	5,000	2,600	1,300	27	115.0	55.0	125.9
EB□M-30	10,500	5,250	3,000	1,500	33	130.0	70.0	184.1

Alternative spherical ball materials ▶ Page 841



Rod ends with female thread: EBRM and EBLM

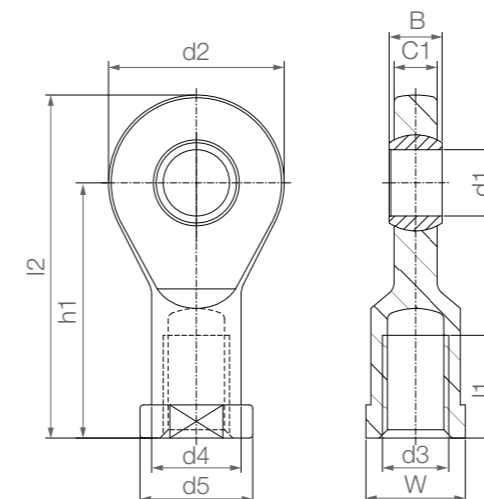

Order key

Type	Size [mm]	Options
E B □ M - 04		Thread L = Left-hand thread R = Right-hand thread
E series		
Housing (female thread)		
Thread		
Metric		
Inner Ø		

Material:  
Housing: igumid G ▶ Page 1654  
Spherical ball: iglidur® W300 ▶ Page 171  
Other spherical ball materials upon request  
▶ Page 841

Dimensions [mm]

Part No.	d1 E10	d2	d3	d4	d5	C1	B	h1	l1	l2	W	Max. pivot angle
EB□M-04 <sup>17)</sup>	4	15	M4	-	-	3.5	5	22.5	9.5	30.0	SW8	33°
EB□M-05	5	19	M5	9.0	11	4.4	6	30	12.0	39.5	SW9	33°
EB□M-06	6	21	M6	11.0	13	4.4	6	30	12.0	40.5	SW11	27°
EB□M-08	8	24	M8	13.0	16	6.0	8	36	14.0	48.0	SW14	24°
EB□M-10	10	29	M10	15.0	19	7.0	9	43	18.0	57.5	SW17	24°
EB□M-10 F	10	29	M10 x 1.25	15.0	19	7.0	9	43	18.0	57.5	SW17	24°
EB□M-12	12	34	M12	18.0	22	8.0	10	50	20.0	67.0	SW19	21°
EB□M-12 F	12	34	M12 x 1.25	18.0	22	8.0	10	50	20.0	67.0	SW19	21°
EB□M-15	15	40	M14	21.0	26	10.0	12	61	26.0	81.0	SW22	21°
EB□M-16 <sup>17)</sup>	16	43	M16	-	-	10.5	13	64.5	26.5	86.0	SW22	21°
EB□M-16 F <sup>17)</sup>	16	43	M16 x 1.5	-	-	10.5	13	64.5	26.5	86.0	SW22	21°
EB□M-17	17	46	M16	24.0	30	11.0	14	67	27.0	90.0	SW27	18°
EB□M-17 F	17	46	M16 x 1.5	24.0	30	11.0	14	67	27.0	90.0	SW27	18°
EB□M-20	20	53	M20 x 1.5	27.0	34	13.0	16	77	31.0	103.5	SW30	16°
EB□M-20 M20	20	53	M20 x 2.5	27.0	34	13.0	16	77	31.0	103.5	SW30	16°
EB□M-25	25	64	M24 x 2.0	34.0	41	17.0	20	94	38.0	126.5	SW36	16°
EB□M-30	30	73	M30 x 2.0	41.0	48	19.0	22	110	47.0	146.5	SW41	13°

<sup>17)</sup> Special design with hexagonal foot

For another spherical bearing material than iglidur® W300, please add "J" to the part number, for example. Example: EBRM-05 J.

Imperial dimensions available  
▶ Page 1606

Rod ends with male thread:  
EARM and EALM



- Maintenance-free dry operation
- Robust
- Durable in varying loads
- Compensation of misalignment errors
- Resistant to edge loads
- Resistant to dirt, dust and lint
- Resistant to corrosion and chemicals
- Vibration-dampening
- Suitable for rotating, oscillating and linear movements
- Lightweight
- Dimensional E series according to DIN ISO 12240
- For temperatures up to +200°C we recommend EARM-HT and EALM-HT ► Page 761

Service life calculation online  
► [www.igus.eu/igubal-expert](http://www.igus.eu/igubal-expert)

Technical data

Part No.	Max. static tensile strain		Max. static axial force		Min. thread depth Thread [mm]	Max. tightening torque Male thread [Nm]	Max. tightening torque through ball [Nm]	Weight [g]
	Short-term	Long-term	Short-term	Long-term				
	[N]	[N]	[N]	[N]				
EA□M-05	550	275	50	25	14	0.4	2.0	2.2
EA□M-06	850	425	80	40	14	0.5	2.5	2.7
EA□M-08	1,600	800	160	80	17	2.0	7.0	5.1
EA□M-10	2,600	1,300	250	125	19	5.0	14.0	8.4
EA□M-10 F	2,600	1,300	250	125	19	3.0	14.0	8.4
EA□M-12	3,100	1,550	300	150	20	6.0	25.0	14.3
EA□M-12 F	3,100	1,550	300	150	20	6.0	25.0	14.3
EA□M-15	3,400	1,700	600	300	24	12.5	30.0	21.1
EA□M-17	3,600	1,800	900	450	26	17.5	35.0	30.2
EA□M-17 F	3,600	1,800	900	450	26	21.0	35.0	30.2
EA□M-20	6,800	3,400	1,700	850	30	25.0	40.0	57.3
EA□M-20 M20	6,800	3,400	1,700	850	30	25.0	40.0	57.3
EA□M-25	7,000	3,500	1,000	500	37	45.0	55.0	94.8
EA□M-30	7,000	3,500	2,000	1,000	46	85.0	70.0	156.4

Alternative spherical ball materials ► Page 841



J4VEM:  
Clearance-free,  
pre-loaded



JEM: Low  
moisture  
absorption



REM:  
Low-cost



J4EM:  
Low-cost and low  
moisture absorption

Rod ends with male thread:  
EARM and EALM

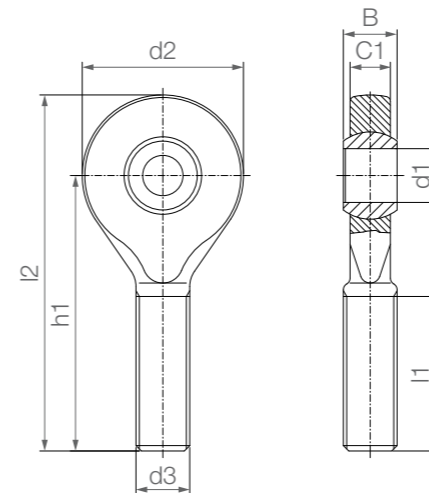

Order key

Type	Size [mm]	Options
E A □ M - 05		
E series		
Housing (male thread)		
Thread		
Metric		
Inner Ø		
		Thread L = Left-hand thread R = Right-hand thread

Material:  
Housing: igumid G ► Page 1654  
Spherical ball: iglidur® W300 ► Page 171  
Other spherical ball materials upon request  
► Page 841

Dimensions [mm]

Part No.	d1 E10	d2	d3	C1	B	h1	l1	l2	Max. pivot angle
EA□M-05	5	19	M5	4.4	6	36.0	20	45.5	33°
EA□M-06	6	21	M6	4.4	6	36.0	20	46.5	27°
EA□M-08	8	24	M8	6.0	8	41.0	24	53.0	24°
EA□M-10	10	29	M10	7.0	9	47.5	27	62.0	24°
EA□M-10 F	10	29	M10 x 1.25	7.0	9	47.5	27	62.0	24°
EA□M-12	12	34	M12	8.0	10	54.0	29	71.0	21°
EA□M-12 F	12	34	M12 x 1.25	8.0	10	54.0	29	71.0	21°
EA□M-15	15	40	M14	10.0	12	63.0	34	83.0	21°
EA□M-17	17	46	M16	11.0	14	69.0	37	92.0	18°
EA□M-17 F	17	46	M16 x 1.5	11.0	14	69.0	37	92.0	18°
EA□M-20	20	53	M20 x 1.5	13.0	16	80.0	43	106.5	16°
EA□M-20 M20	20	53	M20 x 2.5	13.0	16	80.0	43	106.5	16°
EA□M-25	25	64	M24 x 2.0	17.0	20	97.0	53	129.0	16°
EA□M-30	30	73	M30 x 2.0	19.0	22	113.0	65	149.5	13°

For another spherical bearing material than iglidur® W300, please add "J" to the part number, for example. Example: EARM-05 J.

High temperature rod ends with female thread: EBRM-HT and EBLM-HT

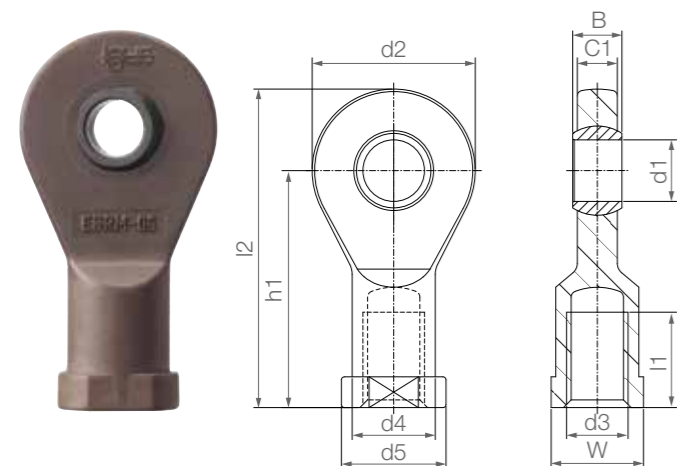

- Applicable up to +200°C
- Robust
- Durable in varying loads
- Compensation of misalignment and edge loads
- Resistant to corrosion and chemicals (chemical table ► Page 1636)
- For underwater applications
- Suitable for rotating, oscillating and linear movements
- Lightweight
- Dimensional E series according to DIN ISO 12240

Order key

Type	Size [mm]	Version
<b>E B □ M - 05 HT</b>		
<b>E series</b>		
<b>Housing (female thread)</b>		
<b>Thread</b>		
<b>Metric</b>		
<b>Inner Ø</b>		
<b>High temperature</b>		

Options:

Thread

- L = Left-hand thread
- R = Right-hand thread

Material:

- Housing: **iguton G** ► Page 1655
- Spherical ball: **iglidur® X** ► Page 279

Technical data

Part No.	Max. static tensile strain		Max. static axial force		Min. thread depth Thread [mm]	Max. tightening torque Female thread [Nm]	Max. tightening torque through ball [Nm]	Weight [g]
	Short-term	Long-term	Short-term	Long-term				
	[N]	[N]	[N]	[N]				
<b>EB □ M-05-HT</b>	625	313	140	70	14	0.4	2.0	3.8
<b>EB □ M-06-HT</b>	832	416	172	86	14	0.5	2.5	5.0
<b>EB □ M-08-HT</b>	1,317	658	175	88	17	2.0	7.0	8.5
<b>EB □ M-10-HT</b>	1,470	735	253	126	19	5.0	14.0	13.7
<b>EB □ M-12-HT</b>	1,600	800	279	139	20	6.0	25.0	21.4

Dimensions [mm]

Part No.	d1 E10	d2	d3	d4	d5	C1	B	h1	l1	l2	W	Max. pivot angle
<b>EB □ M-05-HT</b>	5	19	M5	9.0	11	4.4	6	30	12	39.5	SW9	33°
<b>EB □ M-06-HT</b>	6	21	M6	11.0	13	4.4	6	30	12	40.5	SW11	27°
<b>EB □ M-08-HT</b>	8	24	M8	13.0	16	6.0	8	36	16	48.0	SW14	24°
<b>EB □ M-10-HT</b>	10	29	M10	15.0	19	7.0	9	43	18	57.5	SW17	24°
<b>EB □ M-12-HT</b>	12	34	M12	18.0	22	8.0	10	50	20	67.0	SW19	21°

Other dimensions available upon request

High temperature rod ends with male thread: EARM-HT and EALM-HT

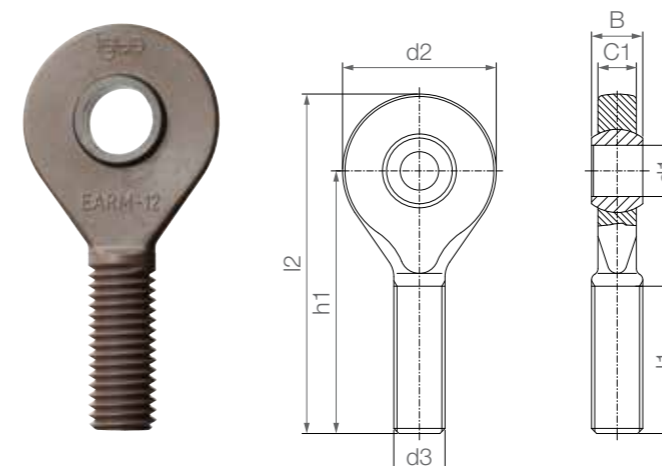

- Applicable up to +200°C
- Robust
- Durable in varying loads
- Compensation of misalignment and edge loads
- Resistant to corrosion and chemicals (chemical table ► Page 1636)
- For underwater applications
- Suitable for rotating, oscillating and linear movements
- Lightweight
- Dimensional E series according to DIN ISO 12240

Order key

Type	Size [mm]	Version
<b>E A □ M - 05 HT</b>		
<b>E series</b>		
<b>Housing (male thread)</b>		
<b>Thread</b>		
<b>Metric</b>		
<b>Inner Ø</b>		
<b>High temperature</b>		

Options:

Thread

- L = Left-hand thread
- R = Right-hand thread

Material:

- Housing: **iguton G** ► Page 1655
- Spherical ball: **iglidur® X** ► Page 279

Technical data

Part No.	Max. static tensile strain		Max. static axial force		Min. thread depth Thread [mm]	Max. tightening torque Male thread [Nm]	Max. tightening torque through ball [Nm]	Weight [g]
	Short-term	Long-term	Short-term	Long-term				
	[N]	[N]	[N]	[N]				
<b>EA □ M-05-HT</b>	380	190	20	10	14	0.4	2.0	2.8
<b>EA □ M-06-HT</b>	600	300	30	15	14	0.5	2.5	3.4
<b>EA □ M-08-HT</b>	931	465	48	24	17	2.0	7.0	6.1
<b>EA □ M-10-HT</b>	1,125	563	57	28	19	5.0	14.0	10.2
<b>EA □ M-12-HT</b>	1,200	600	65	33	20	6.0	25.0	15.7

Dimensions [mm]

Part No.	d1 E10	d2	d3	C1	B	h1	l1	l2	Max. pivot angle
<b>EA □ M-05-HT</b>	5	19	M5	4.4	6	36.0	20	45.5	33°
<b>EA □ M-06-HT</b>	6	21	M6	4.4	6	36.0	20	46.5	27°
<b>EA □ M-08-HT</b>	8	24	M8	6.0	8	41.0	24	53.0	24°
<b>EA □ M-10-HT</b>	10	29	M10	7.0	9	47.5	27	62.0	24°
<b>EA □ M-12-HT</b>	12	34	M12	8.0	10	54.0	29	71.0	21°

Other dimensions available upon request

Rod ends with female thread, suitable for food contact: EBRM-FC

 Order key

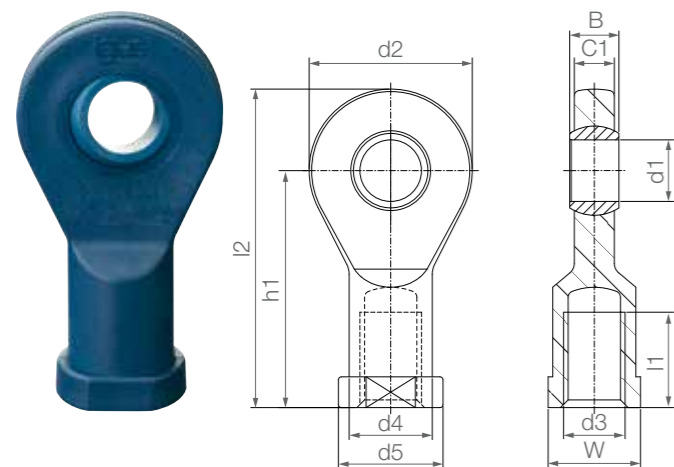

Type	Size [mm]	Version
<b>E B R M - 06 FC</b>		
<b>E series</b>		
Housing (female thread)		
Thread		
Metric		
Inner Ø		
Suitable for food contact		

- Made from FDA and EU10/2011-compliant materials
- Lubrication and maintenance-free
- Optically and magnetically detectable
- In industry standard blue
- Corrosion and media-resistant
- Vibration-dampening
- Cost-effective

 **Material:**  
Housing: **igumid FC** ▶ Page1655  
Spherical ball: **iglidur® FC180** ▶ Page 1652

**Technical data**

Part No.	Max. static tensile strain		Max. static axial force		Min. thread depth	Max. tightening torque	Max. tightening torque	Weight			
	Short-term	Long-term	Short-term	Long-term					Thread	Female thread	through ball
<b>EBRM-06-FC</b> <b>New</b>	1,300	650	300	150	8.0	1.5	2.0	4.0			
<b>EBRM-08-FC</b> <b>New</b>	1,900	950	500	250	11.0	5.0	4.0	7.0			
<b>EBRM-10-FC</b> <b>New</b>	2,220	1,100	500	250	13.0	10.0	6.0	11.4			
<b>EBRM-10-FC-F</b> <b>New</b>	2,220	1,100	500	250	13.0	10.0	6.0	11.4			
<b>EBRM-12-FC</b> <b>New</b>	3,000	1,500	800	400	14.0	15.0	6.0	17.4			

**Dimensions [mm]**

Part No.	d1	d2	d3	d4	d5	C1	B	h1	l1	l2	W	Max. pivot angle
	E10											
<b>EBRM-06-FC</b> <b>New</b>	6	21	M6	11.0	13	4.4	6	30	12	40.5	SW11	27°
<b>EBRM-08-FC</b> <b>New</b>	8	24	M8	13.0	16	6.0	8	36	14	48.0	SW14	24°
<b>EBRM-10-FC</b> <b>New</b>	10	29	M10	15.0	19	7.0	9	43	18	57.5	SW17	24°
<b>EBRM-10-FC-F</b> <b>New</b>	10	29	M10 x 1.25	15.0	19	7.0	9	43	18	57.5	SW17	24°
<b>EBRM-12-FC</b> <b>New</b>	12	34	M12	18.0	22	8.0	10	50	20	67.0	SW19	21°

Left-hand thread and other dimensions available upon request

Rod ends with female thread, suitable for food contact: KCRM-FC

 Order key

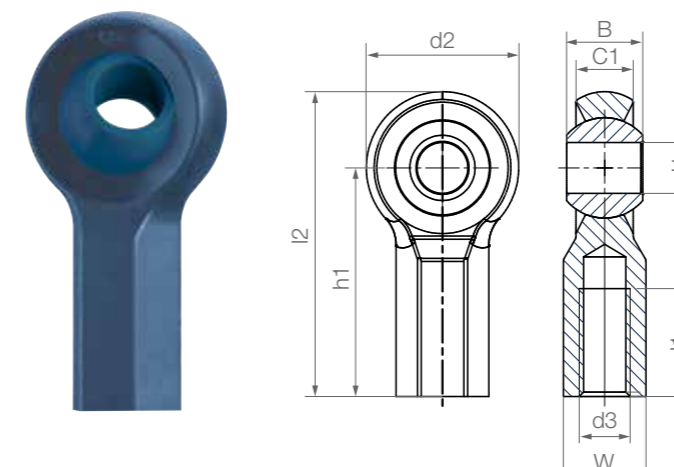

Type	Size [mm]	Version
<b>K C R M - 06 FC</b>		
<b>K series</b>		
Housing (female thread)		
Thread		
Metric		
Inner Ø		
Suitable for food contact		

- Made from FDA and EU10/2011-compliant materials
- Lubrication and maintenance-free
- Optically and magnetically detectable
- In industry standard blue
- Corrosion and media-resistant
- Vibration-dampening
- Cost-effective

 **Material:**  
Housing: **igumid FC** ▶ Page1655  
Spherical ball: **iglidur® FC180** ▶ Page 1652

**Technical data**

Part No.	Max. static tensile strain		Max. static axial force		Min. thread depth	Max. tightening torque	Max. tightening torque	Weight			
	Short-term	Long-term	Short-term	Long-term					Thread	Male thread	through ball
<b>KCRM-06-FC</b> <b>New</b>	1,300	650	400	400	8.0	1.0	2.0	4.3			

**Dimensions [mm]**

Part No.	d1	d2	d3	C1	B	h1	l1	l2	W	Max. pivot angle
	E10									
	Without stainless steel sleeve									
<b>KCRM-06-FC</b> <b>New</b>	6	20	M6	7.0	9.0	30	13.5	40.0	SW10	40°

Left-hand thread and other dimensions available upon request