

E4.1

Largest modular system for almost any application



Advantages of the E4.1 system:

- Undercut design for high lateral stability, high strength for long travels and for large unsupported lengths
- Especially suited for side-mounted applications
- Noise-reducing brake and optional noise dampers
- Inner and outer links for quick assembly, with or without pretension
- Many modular options and accessories available



When to use another e-chain® series:

- For easy, tool-free opening and closing - the next generation of easy-to-assemble e-chains®
▶ E4Q, page 580
- When an e-chain® must fulfil IPA Class 1 cleanroom standard
▶ E6.1, page 832
- When a light, cost-effective e-chain®/e-tube with higher dynamics and a larger inner space with the same exterior dimensions is required ▶ E4.1L, page 538
- For applications that require special high unsupported lengths at different angles of elevation - igus® plastic-steel hybrid e-chain®
▶ YE, page 772



Attachment from any side: with KMA mounting brackets

Swarf protection: openable lids

Quiet operation: optional noise dampers

Long service life: lateral gliding surfaces

Strong: crossbars with double locking

Straight run: due to inner/outer link principle

No pretension: NC version by rotating the outer link

Precise separation: crossbar with visual scale

High strength: due to undercut design

Low-noise operation: due to integrated brake

Largest modular system for almost any application - E4.1

The E4.1 system combines all the advantages of its three predecessors. Series E4.1 is stronger whilst having the same or even smaller dimensions than previous versions. Almost all accessories and mounting dimensions are identical. You can increase the service life of your application with the igus® system E4.1 whilst reducing cost.

- Undercut design for high lateral stability
- High push/pull strength for long travels and large unsupported lengths
- Especially suited for side-mounted applications
- Noise-reducing brake and optional noise dampers
- Inner and outer links for quick assembly, with or without pretension

Typical industries and applications

- Cranes ● Indoor cranes ● Composting plants ● Sewage plants ● Machine tools ● General mechanical engineering ● Material handling technology ● Cooling technology ● Construction machinery ● Woodworking ● Robots and handling equipment



IPA Qualification Certificate - Report IG 1303-640-1: ISO Class 2, according to DIN EN ISO 14644-1 for series E4.32.10.063.0.CR at v = 0.5m/s, 1,0m/s, 2,0m/s

41dB(A) - value determined at the igus® test-lab, v = 1.8m/s unsupported, series E4.21.060.038.0

Electrically conductive ESD e-chains® - several series available from stock

Series	Inner height <i>hi</i> [mm]	Inner width <i>Bi</i> [mm]	Outer width <i>Ba</i> [mm]	Outer height <i>ha</i> [mm]	Bend radius <i>R</i> [mm]	Unsupported length ≤ [m]	Page
--------	--------------------------------	-------------------------------	-------------------------------	--------------------------------	------------------------------	--------------------------	------



e-chains® with crossbars every link
the all-rounder - also for particularly demanding applications
Please observe the guidelines for the e-chains® selection, further information ► From page 114

E4.21	21	30 - 140	44 - 154	28	038 - 200	2.50	626
E4.28	28	40 - 300	60 - 320	42	055 - 250	2.50	632
E4.32	32	50 - 400	73 - 423	54	063 - 300	3.30	640
E4.42	42	50 - 400	76 - 426	64	075 - 350	4.00	650
E4.56	56	50 - 600	84 - 634	84	135 - 500	5.00	662
E4.80	80	50 - 600	100 - 650	108	150 - 1,000	6.20	674
E4.112	112	50 - 600	102 - 652	140	200 - 1,000	6.50	686
E4.162	162	200 - 600	256 - 656	195	250 - 1,000	6.75	694
800	200	200 - 600	260 - 660	236	325 - 1,000	8.00	698
840	204	100 - 563	160 - 623	236	325 - 1,000	8.00	702
E4.350	350	400 - 800	540 - 940	450	500 - 1,000	6.20	706



e-chains® with crossbars every 2nd link
the cost-effective, easy-to-install alternative for almost all applications
Please observe the guidelines for the e-chains® selection, further information ► From page 114

H4.32	32	50 - 400	73 - 423	54	063 - 300	3.30	640
H4.42	42	50 - 400	76 - 426	64	075 - 350	4.00	650
H4.56	56	50 - 600	84 - 634	84	135 - 500	5.00	662
H4.80	80	50 - 600	100 - 650	108	150 - 1,000	6.20	674



e-tubes
fully enclosed, excellent cable protection
Please observe the guidelines for the e-chains® selection, further information ► From page 114

R4.28	28	50 - 300	70 - 320	42	075 - 250	2.50	632
R4.32	32	50 - 300	73 - 323	54	125 - 300	3.30	640
R4.42	42	50 - 300	76 - 326	64	125 - 350	4.00	650
R4.56	56	75 - 462	109 - 497	84	135 - 500	5.00	662
R4.80	80	100 - 462	150 - 513	108	200 - 1,000	6.20	674
R4.112	108	200 - 500	252 - 552	140	250 - 1,000	6.50	686

Available from stock. Ready to ship in 24 - 48hrs.*
*Average time before the ordered goods are dispatched.

System E4.1 | Any application with one e-chain®

Undercut design combined with the inner/outer-link solution

System E4.1 | Moving energy made easy

High stability and strength and easy installation

Smooth, cable-friendly inner surfaces

Low-noise operation due to integrated brake on the radial stop-dogs

Smooth and wear-resistant gliding surface - no additional glide shoes required

Option with or without camber simply by reversing outer links

ESD version ideal with large undercut contact area

Strong crossbars with double locking

Double vertical stop-dog system for larger unsupported lengths

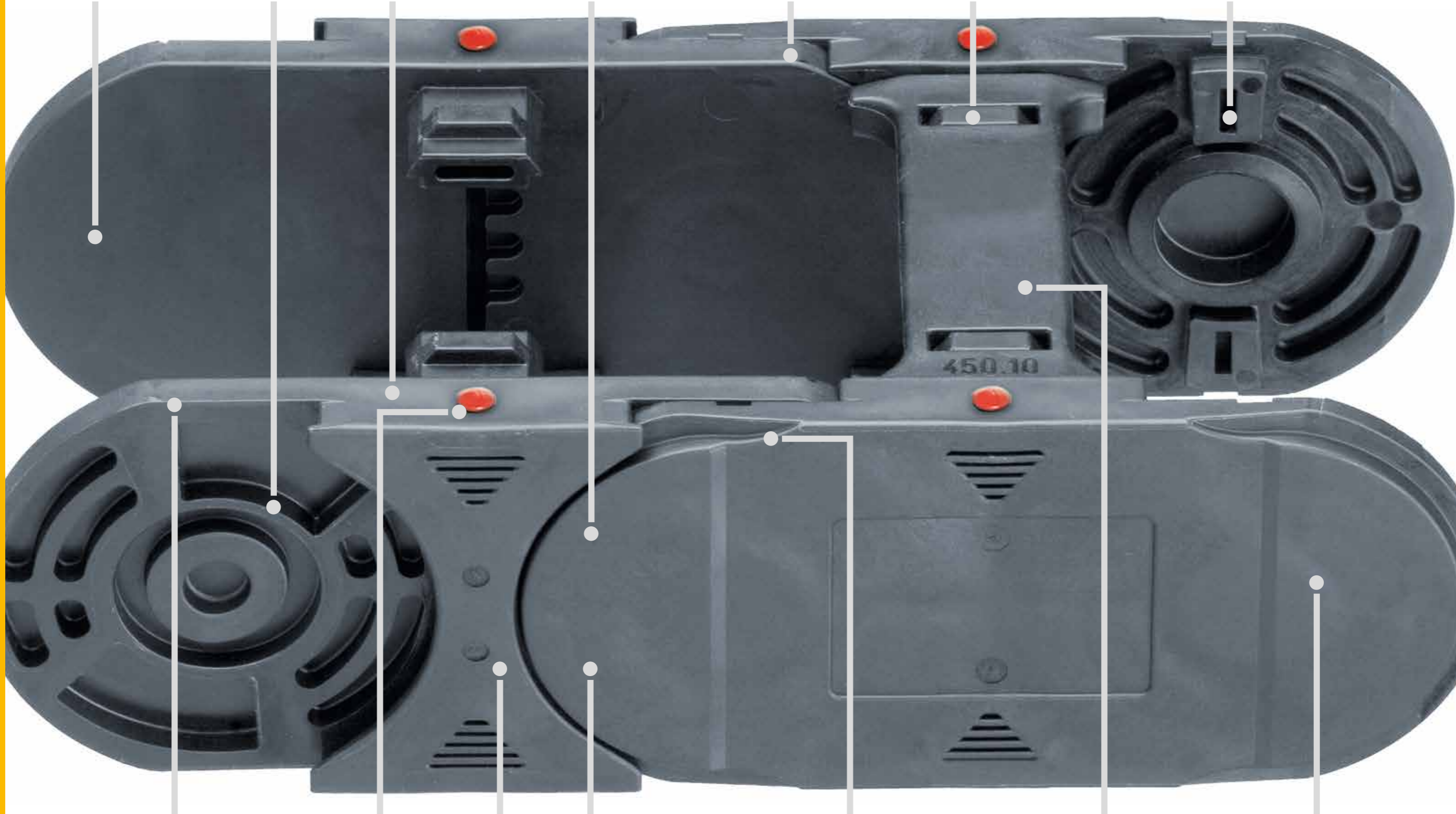

Special e-chain® link contour provides low rolling noise

Optional noise dampers

Straight run and fast assembly due to inner/outer-link design

Very high stability due to the undercut design

Cable-friendly, rounded crossbar

Integrated lateral wear pads for a long service life (also for side-mounted applications)



Lean separators enable extremely fast cable filling in several layers

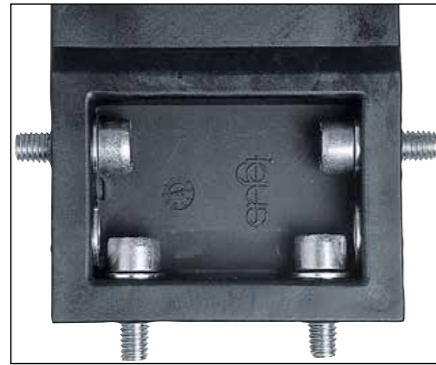

KMA mounting brackets with attachment options from any side

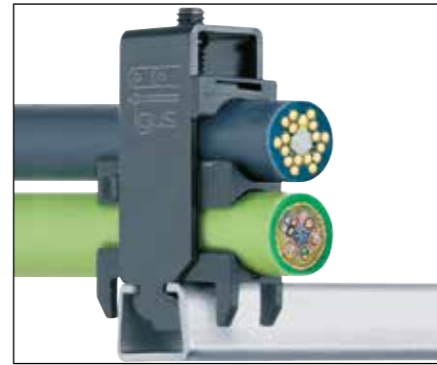

Strain relief e.g. clamps, tie-wrap plates, nuggets, etc. ▶ From page 1392



Aluminium and steel support tray for support of the lower run ▶ From page 1362



Aluminium SuperTrough - the standard igus® guide trough ▶ From page 1298



Safe parallel guiding of corrugated tubes with the optional, external TUB guidance

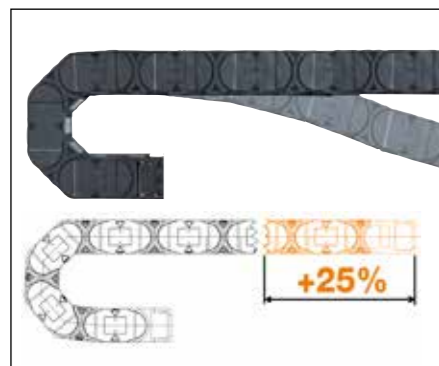

Up to 25% longer unsupported length with XXL material ▶ www.igus.eu/E4.1



Optimised interior separation products, cables last up to 4 times longer



autoglide crossbars - long travels without guide troughs



Flexible extender crossbar range - e-chain® extender for enlarging the interior, large range of widths possible



Round or square extender crossbar with fixed width - safe guiding for large hoses



The extension link design allows virtually unlimited side-by-side extension

Technical data





	Speed gliding / acceleration gliding	≤ 10 [m/s] / ≤ 50 [m/s ²]
	Speed FL_G / acceleration FL_G	≤ 20 [m/s] / ≤ 200 [m/s ²]
	Speed FL_B / acceleration FL_B	≤ 3 [m/s] / ≤ 6 [m/s ²]
	Material - permitted temperature °C, igumid G	-40°C / +120°C
	Flammability class, igumid G	VDE 0304 IIC UL94-HB

■ FL_G = unsupported with straight upper run ■ FL_B = unsupported with permitted sag

Installation types, maximum travels

Series	Unsupported	Gliding	Vertical hanging	Vertical standing	Side mounted unsupported	Rotary	Zig-zag	Unsupported length lower run
E4.21	≤ 5.0m	≤ 120m	≤ 40m	≤ 3.0m	≤ 1.0m	with rework	upon request	upon request
E4.28/R4.28	≤ 5.0m	≤ 200m	≤ 80m	≤ 5.0m	≤ 1.2m	with rework	upon request	upon request
E4.32/H4.32/R4.32	≤ 6.6m	≤ 200m	≤ 80m	≤ 5.0m	≤ 1.5m	with rework	upon request	upon request
E4.42/H4.42/R4.42	≤ 8.0m	≤ 300m	≤ 100m	≤ 6.0m	≤ 2.0m	with rework	upon request	upon request
E4.56/H4.56/R4.56	≤ 10.0m	≤ 400m	≤ 100m	≤ 6.0m	≤ 2.5m	with rework	upon request	upon request
E4.80/H4.80/R4.80	≤ 12.4m	≤ 400m	≤ 120m	≤ 6.0m	≤ 3.0m	with rework	upon request	upon request
E4.112/R4.112	≤ 13.0m	≤ 450m	≤ 120m	≤ 6.0m	≤ 3.0m	with rework	upon request	upon request
E4.162	≤ 13.5m	≤ 450m	≤ 120m	≤ 6.0m	upon request	with rework	upon request	upon request
800	≤ 16.0m	≤ 450m	≤ 120m	≤ 6.0m	≤ 6.0m	with rework	upon request	upon request
840	≤ 16.0m	≤ 450m	≤ 120m	≤ 6.0m	≤ 6.0m	with rework	upon request	upon request
E4.350	≤ 13.0m	upon request	upon request	upon request	with rework	upon request	upon request	upon request

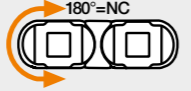
Options with order keys | Examples based on series E4.56/H4.56/R4.56

 Standard	<i>Optional noise dampers</i>	<i>Simply turn outer side link, no additional rework</i>	<i>Reverse Bend Radius (RBR) for circular movements</i>
Part No. Standard 	Part No. Low noise (with pads) 	Part No. NC version 	Part No. RBR 
E4.56.30.R.0 e-chain® with crossbars every link	ES4.56.30.R.0 e-chain® with crossbars every link	E4.56.30.R.0.NC e-chain® with crossbars every link	E4.56.30.R1/R2.0 e-chain® with crossbars every link
H4.56.30.R.0 e-chain® with crossbars every 2 nd link	HS4.56.30.R.0 e-chain® with crossbars every 2 nd link	H4.56.30.R.0.NC e-chain® with crossbars every 2 nd link	H4.56.30.R1/R2.0 e-chain® with crossbars every 2 nd link
R4.56.30.R.0 e-tube, closed	RS4.56.30.R.0 e-tube, closed	R4.56.30.R.0.NC e-tube, closed	RBR for e-tubes - please consult igus®
 Ready to ship in 24 - 48hrs.*	Ready to ship in 12 business days*	Ready to ship in 24 - 48hrs.*	Ready to ship in 12 business days*[Ⓞ]

 ESD version - some series available from stock - further information and the complete product range ► from page 142

 RBR version (Reverse Bend Radius) - some radii available from stock - further information and the complete product range ► from page 130

Order example | Examples based on series E4.56

 **Order example for complete e-chain® (3.0m), colour black, with mounting brackets and interior separation:**



e-chain® (3.0m)	Please indicate e-chain® length or number of links: 3.0m or 33 links	E4.56.30.300.0
+ Mounting brackets	1 set (with odd number of links and integrated C-profiles)	E4.560.30.1.12.C
Interior separation	with 2 separators assembled every 2 nd link	2 x 56.1.1
Order text:	3m E4.56.30.300.0 + E4.560.30.1.12.C + 2 x 56.1.1	

Magnetically detectable plastic e-chains®

- For the food and tobacco industry
- The material igumid DT is detected to the tiniest fragment all common metal detection systems and can therefore be selected automatically
- Particles as small as 1.0mm can be recognised for fragments passing at speeds of 20m/min.

More information ► upon request

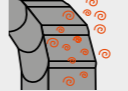





<i>Unsupported lengths +25% possible</i>	<i>e-tube - no burning in of hot swarf up to 850°C</i>	<i>ESD - electrically conductive material</i>
Part No. XXL material 	Part No. igumid HT 	Part No. igumid ESD 
E4.56.30.R.0.XXL e-chain® with crossbars every link ¹⁾	R4.56.30.R.0.HT Complete e-tube ²⁾	E4.56.30.R.0.ESD e-chain® with crossbars every link
H4.56.30.R.0.XXL e-chain® with crossbars every 2 nd link ¹⁾	R4.56.30.HT.R.0 Lid and shelves made of HT material (side plates of standard material)	H4.56.30.R.0.ESD e-chain® with crossbars every 2 nd link
R4.56.30.R.0.XXL e-tube, closed ¹⁾		R4.56.30.R.0.ESD e-tube, closed
Ready to ship in 12 business days*	Ready to ship in 6 weeks*	Ready to ship in 12 business days*[▲]

*Average time before the ordered goods are dispatched.







¹⁾ Side-bands made from XXL material ²⁾ Available upon request. Delivery time upon request

Order key and colour examples | Examples based on series E4.56/H4.56/R4.56

 **Order key**

e-chain® with crossbars every link	E4.56.30.300.0
e-chain® with crossbars every 2 nd link	H4.56.30.300.0
e-tube fully enclosed	R4.56.30.300.0
Series / Type	
Inner height	
Width index (depends on B)	
Bend radius R	
Colour index (standard black)	

Order index for colour options

Colour	Order index	Colour	Order index		
 Black	Standard	.0	 Orange	Special colour	.2
 Silver-grey	Special colour	.31	 Yellow	Special colour	.4
 White	Special colour	.1	 Light grey	Special colour	.14
 Grey-white	Special colour	.1S			

Black e-chains® ready to ship in 24 - 48hrs.*

Above special colours upon request.

Aluminium lid for plastic e-tube R4.1

- Lid notches allow easy positioning of the interior separation
 - Special plastic clips facilitate easy assembly
 - Any width possible, openable lids from both sides (material: aluminium EN AW-6060)
- More information ► upon request**



Strong due to undercut design, small inner height



e-chains® | Series E4.21 | Crossbars every link (crossbars removable along the inner and outer radius)

Part No.	Bi	Ba	E4.21	Part No.	Bi	Ba	E4.21
e-chains®	[mm]	[mm]	[kg/m]	e-chains®	[mm]	[mm]	[kg/m]
E4.21.030.R.0 [▲]	30	44	≈ 0.60	E4.21.090.R.0	90	104	≈ 0.82
E4.21.040.R.0 [▲]	40	54	≈ 0.64	E4.21.100.R.0	100	114	≈ 0.85
E4.21.050.R.0 [▲]	50	64	≈ 0.67	E4.21.110.R.0	110	124	≈ 0.89
E4.21.060.R.0 [▲]	60	74	≈ 0.71	E4.21.120.R.0	120	134	≈ 0.92
E4.21.070.R.0 [▲]	70	84	≈ 0.74	E4.21.140.R.0	140	154	≈ 0.99
E4.21.080.R.0 [▲]	80	94	≈ 0.78				

[▲] ESD version (Electro Static Discharge) available from stock. More information ▶ From page 142

⊙ All widths of the E4.21 with crossbars every link are available from stock as RBR version (Reverse Bend Radius) 048/390. More information ▶ From page 130

Available bend radii

R [mm] | 038 | 048[⊙] | 063 | 075 | 100 | 150 | 200 |

Complete Part No. with required radius (R). Example: E4.21.120.100.0 = crossbars every link

ESD - many sizes from stock

- Standardised product made from igumid ESD
 - ESD material tested for over 10 million cycles for the toughest requirements
 - Short delivery times including mounting brackets and interior separation; 24hrs, from stock
- More information and the complete product range
▶ From page 142 or at ▶ www.igus.eu/esd



Rotating energy supply systems with Reverse Bend Radius (RBR) - some radii available from stock

- Maximum rotation angle in minimal installation space
 - Minimal friction forces and maximum service life
 - Short delivery times, from stock
- More information and the complete product range ▶ From page 130



Unsupported applications | Short travels

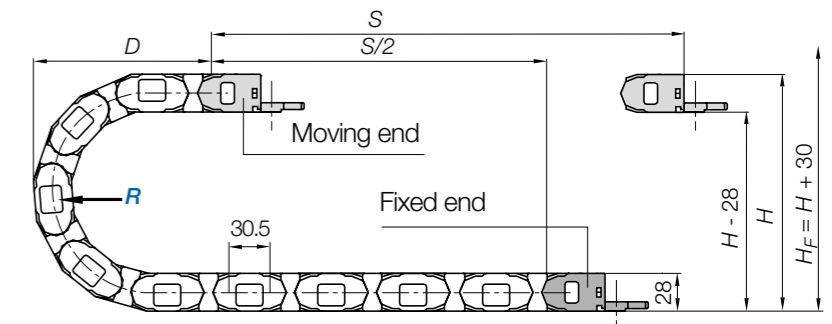
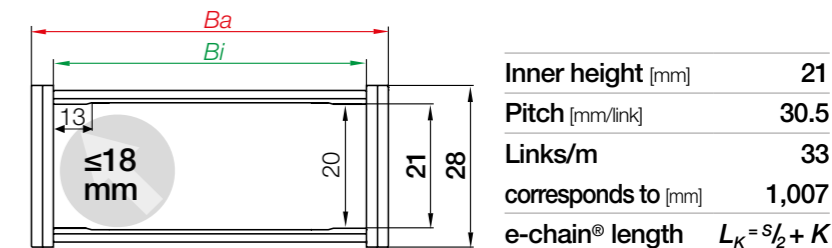
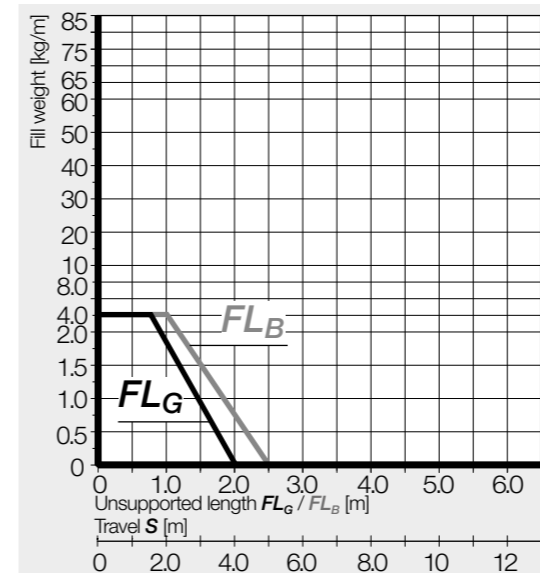

R	038	048	063	075	100	150	200
H	104	124	154	178	228	328	428
D	98	108	123	135	160	210	260
K	185	215	260	300	380	535	690

The required clearance height: $H_F = H + 30$ mm (with 1.5kg/m fill weight)

Gliding applications | For travel lengths from 10m to max. 120m

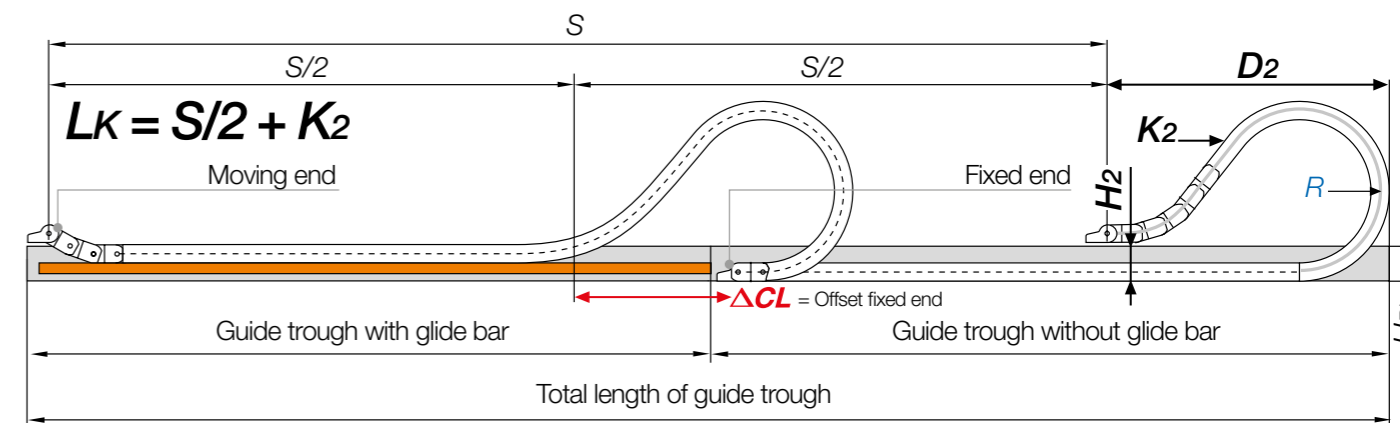

Note: We recommend the project planning of such a system to be carried out by igus®. In case of travels between 4 and 10m we recommend an e-chain® with a longer unsupported length.

R	038	048	063	075	100	150	200
H ₂	76	96	126	152	135	135	135
D ₂	85	95	110	120	430	580	730
K ₂	185	215	260	300	640.5	945.5	1250.5
ΔCL	-	-	-	-	270	370	470

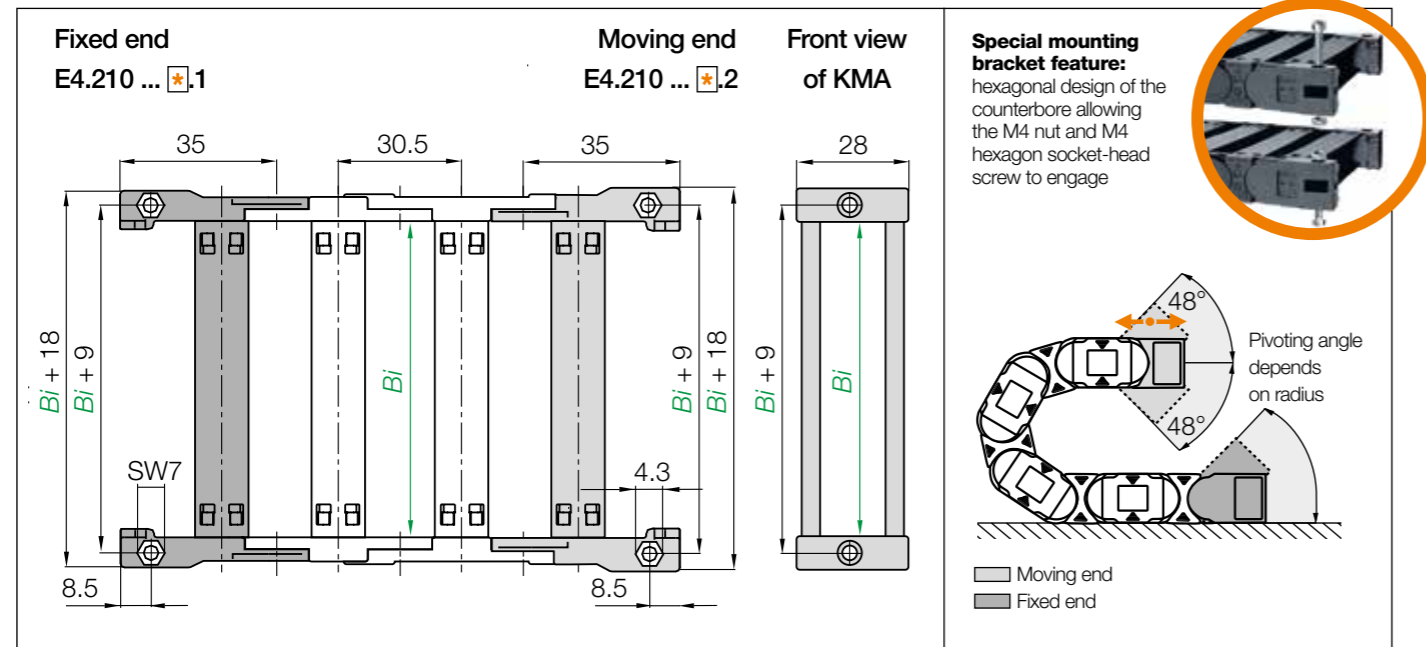

KMA pivoting | Recommended for unsupported and gliding applications

Width index	Part No. full set KMA pivoting	Bi [mm]	Width index	Part No. full set KMA pivoting	Bi [mm]
030.	E4.210.030.[1].12	30	090.	E4.210.090.[1].12	90
040.	E4.210.040.[1].12	40	100.	E4.210.100.[1].12	100
050.	E4.210.050.[1].12	50	110.	E4.210.110.[1].12	110
060.	E4.210.060.[1].12	60	120.	E4.210.120.[1].12	120
070.	E4.210.070.[1].12	70	140.	E4.210.140.[1].12	140
080.	E4.210.080.[1].12	80			

(KMA = polymer metal mounting bracket)

Note: [1] The e-chains® may end with either an inner or an outer side link. An outer side link should always be the first e-chain® link at the moving end. Please specify the index [1] (for odd) or [2] (for even) depending on an even or odd number of links required.

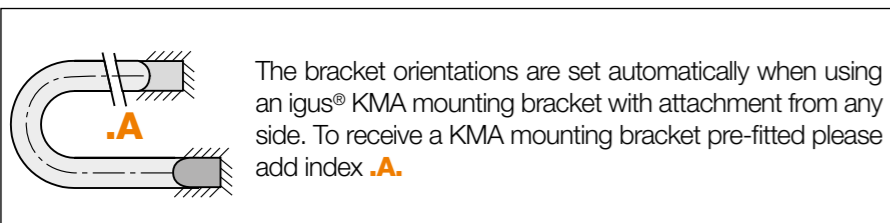
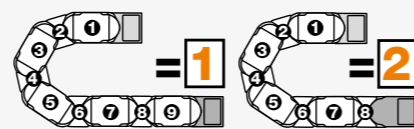

E4.210.120.[2].12.A Order example



Strain relief e.g. clamps, tiwrap plates, nuggets and clips are available from stock. The complete chainfix range with ordering options ▶ From page 1392

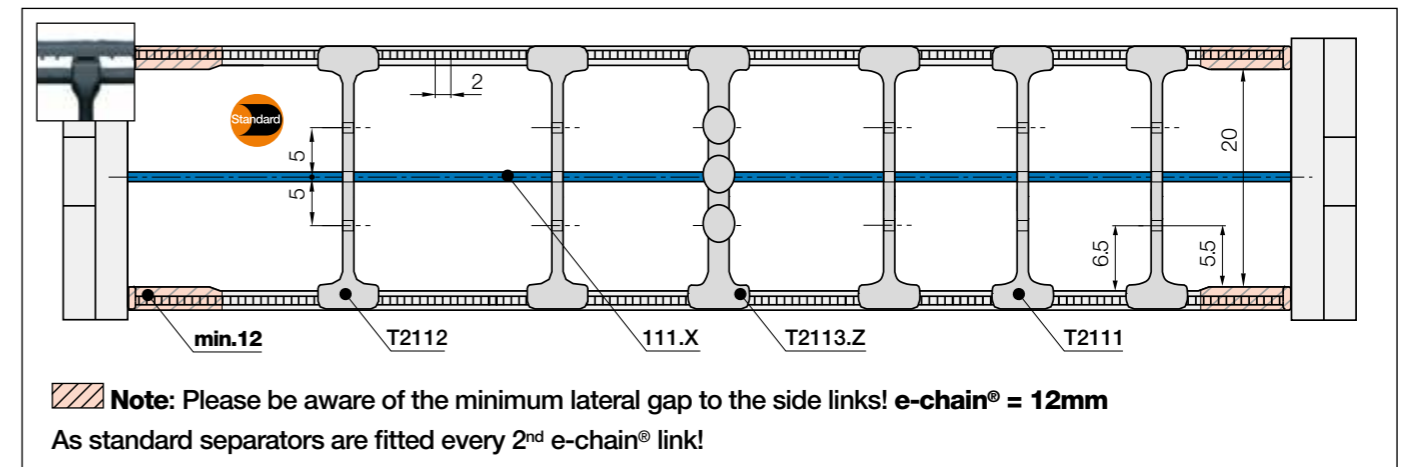

Slotted separator*

For a vertical subdivision. The slot allows basic vertical/horizontal shelving arrangements.

Standard		unassembled	T2102
		assembled	T2112

Slotted notch separator*

Can be locked/fixd securely due to special recesses on the crossbars of the e-chain®. The separator cannot slide sideways during operation.

Standard		unassembled	T2101
		assembled	T2111

Full-width shelf for e-chains®

This option is for applications with many small cables with similar diameters. For full-width separation.

Standard		unassembled	110.X
		assembled	111.X

Slotted separator*
For a vertical subdivision. The slot allows basic vertical/horizontal shelving arrangements.

Slotted notch separator*
Can be locked/fixd securely due to special recesses on the crossbars of the e-chain®. The separator cannot slide sideways during operation.

Full-width shelf
This option is for applications with many small cables with similar diameters. For full-width separation.

*Note: not suitable for Bi 030

Full-width shelves Width = X [mm]	X [mm]	unassembled		assembled		X [mm]	unassembled		assembled	
		unassembled	assembled	unassembled	assembled		unassembled	assembled		
Standard	030	110.30	111.30	070	110.70	111.70	110	110.110	111.110	
	040	110.40	111.40	080	110.80	111.80	120	110.120	111.120	
	050	110.50	111.50	090	110.90	111.90				
	060	110.60	111.60	100	110.100	111.100				

Interior separation | To allow faster filling

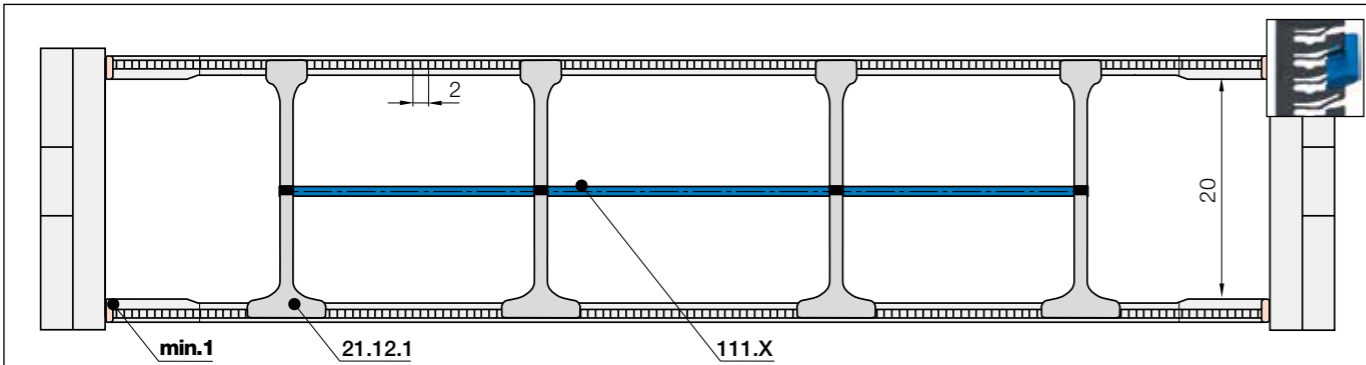

Note: Please be aware of the minimum lateral gap to the side links! **e-chain® = 1mm**
As standard separators are fitted every 2nd e-chain® link!

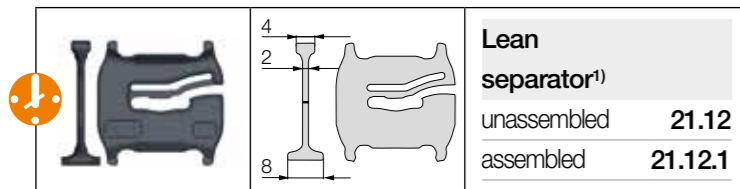
**Lean separators¹⁾**

For quick fitting of shelves in several layers.

1) Note: Please combine maximum 4 lean separators with one shelf. Not suitable for side-mounted e-chains®!

With the lean separator you can quickly insert several layers of cables into the e-chain® and reduce the installation time by up to 50%²⁾.

²⁾ Lean interior separation vs. Standard separator - measured on a 4m long e-chain® fitted with 12 cables in the igus® readychain® factory

**Aluminium support tray**

- Corrosion-resistant and seawater-resistant aluminium rails with adjustable width
 - Noise-reducing glide strip integrated as standard
 - Easy installation and connection of the e-tube
 - Open design - dirt and debris fall through
- More information ► From page 1362**

**Reduce assembly time - E4 e-chain® opener**

- e-chain® opener tools for easy opening and closing of e-chains®
 - Simple opening and closing of e-chain® crossbars
 - Also for use in hard to reach locations
 - Significant assembly time reduction
- More information ► www.igus.eu/E4savetime**

**Separator with integrated strain relief teeth**

- Can be integrated into the mounting bracket or placed at any point
 - Combines strain relief and interior separation, for restricted space conditions
 - Strain relief separator is easy to assemble without any screws
- Part No. T2103.Z - more information ► From page 1424**



Many e-chains® are used in this customised CNC-machine for the woodworking industry

Strong due to undercut design, small inner height

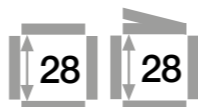

e-chains® | Series E4.28 | Crossbars every link (crossbars removable along the inner and outer radius)
e-tubes | Series R4.28 | Fully enclosed (lids openable along the outer radius, from one side)

Part No.	Bi	Ba	E4.28	R4.28	Part No.	Bi	Ba	E4.28	R4.28
e-chains® / e-tubes	[mm]	[mm]	[kg/m]	[kg/m]	e-chains® / e-tubes	[mm]	[mm]	[kg/m]	[kg/m]
E4.▲ - 28.040.R.0	40	60	≈ 1.06	-	E4.▲ R4. 28.125.R.0	125	145	≈ 1.51	≈ 2.78
E4.▲ R4. 28.050.R.0	50	70	≈ 1.11	≈ 2.20	E4. R4. 28.150.R.0	150	170	≈ 1.61	≈ 3.02
E4. - 28.052.R.0	52	72	≈ 1.13	-	E4. R4. 28.175.R.0	175	195	≈ 1.71	≈ 3.26
E4.▲ - 28.062.R.0	62	82	≈ 1.17	-	E4. R4. 28.200.R.0	200	220	≈ 1.84	≈ 3.50
E4.▲ - 28.070.R.0	70	90	≈ 1.20	-	E4. R4. 28.225.R.0	225	245	≈ 1.99	≈ 3.82
E4.▲ R4. 28.075.R.0	75	95	≈ 1.23	≈ 2.32	E4. R4. 28.250.R.0	250	270	≈ 2.14	≈ 3.98
E4.▲ - 28.087.R.0	87	107	≈ 1.28	-	E4. - 28.275.R.0	275	295	≈ 2.27	-
E4.▲ R4. 28.100.R.0	100	120	≈ 1.37	≈ 2.54	E4. R4. 28.300.R.0	300	320	≈ 2.39	≈ 4.46

▲ ESD version (Electro Static Discharge) available from stock. More information ▶ From page 142

*Radius not available for e-tubes

Available bend radii

R [mm] | 055* | 063* | 075 | 100 | 125 | 150 | 175 | 200 | 250 |

Complete Part No. with required radius (R). Example:

E4.28.100.100.0 = crossbars every link / R4.28.105.100.0 = fully enclosed

ESD - many sizes from stock

- Standardised product made from igumid ESD
- ESD material tested for over 10 million cycles for the toughest requirements
- Short delivery times including mounting brackets and interior separation; 24hrs, from stock

More information and the complete product range

▶ From page 142 or at ▶ www.igus.eu/esd



Unsupported applications | Short travels

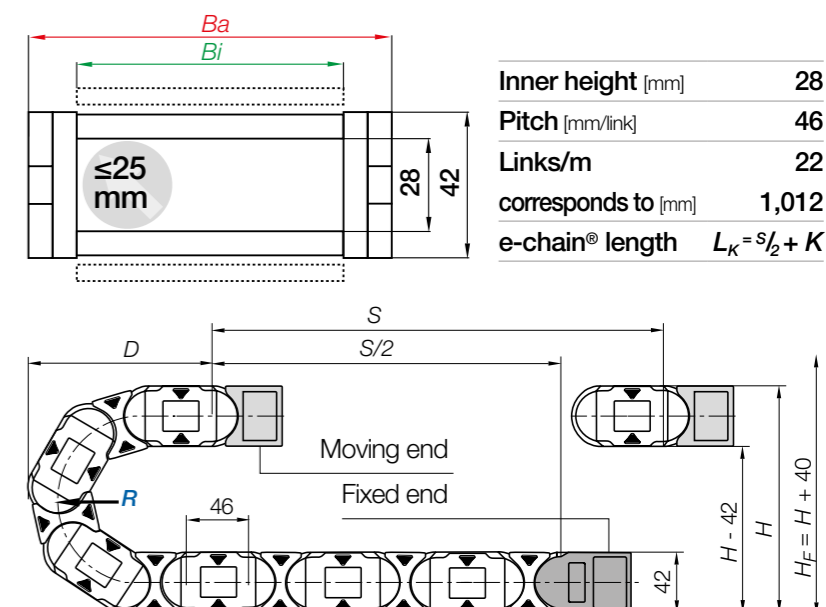
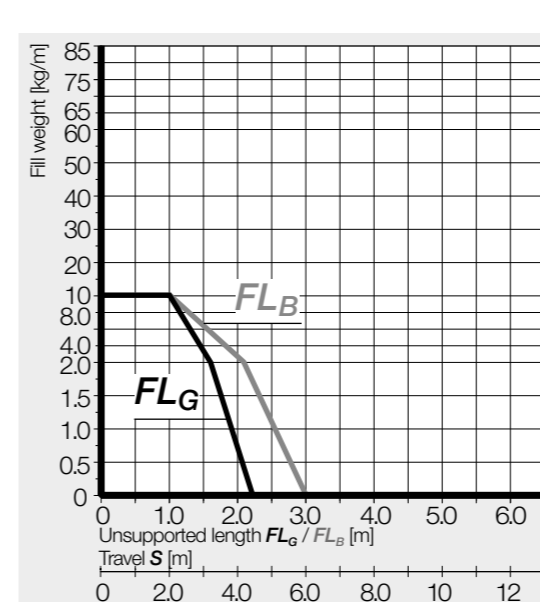

R	055*	063*	075	100	125	150	175	200	250
H	152	168	192	242	292	342	392	442	542
D	145	153	165	190	215	240	265	290	340
K	265	290	330	410	485	565	645	725	880

The required clearance height: $H_F = H + 40\text{mm}$ (with 1.0kg/m fill weight)

*Radius not available for e-tubes

Gliding applications | For travel lengths from 10m to max. 200m

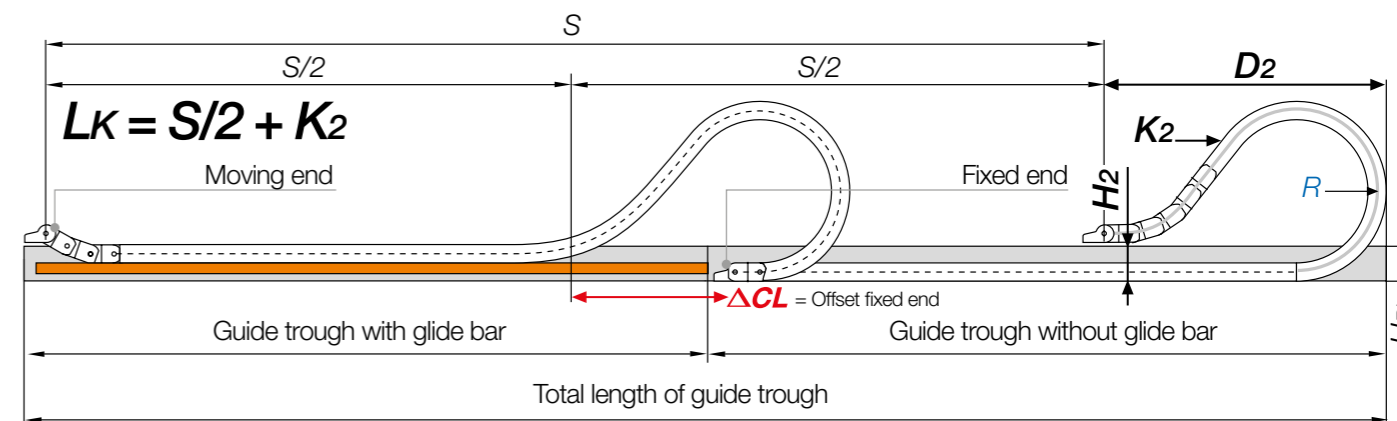

Note: We recommend the project planning of such a system to be carried out by igus®.

In case of travels between 5 and 10m we recommend an e-chain® with a longer unsupported length.

R	055*	063*	075	100	125	150	175	200	250
H ₂	110	126	150	158	158	158	158	158	158
D ₂ ⁺²⁵	122	130	142	350	490	530	665	730	935
K ₂	265	290	330	598	782	920	1,104	1,242	1,610
ΔCL	-	-	-	150	270	300	400	450	600

*Radius not available for e-tubes

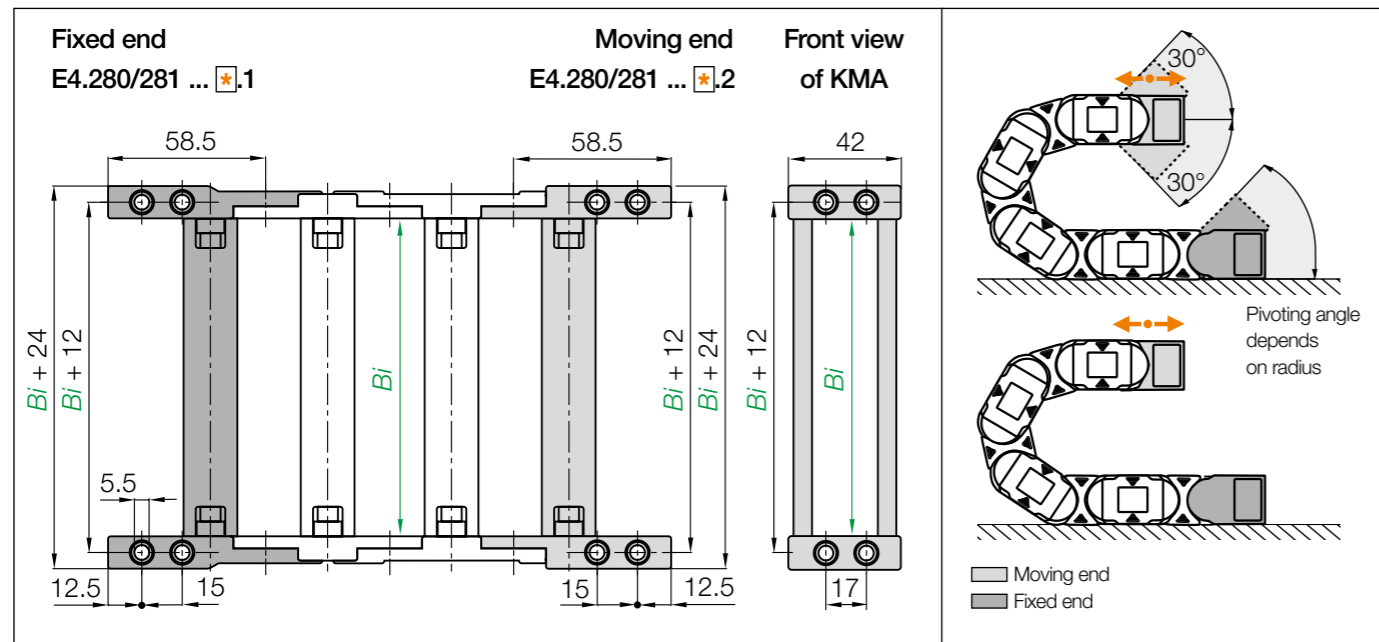

KMA pivoting | Recommended for unsupported and gliding applications
KMA locking | Recommended for vertical hanging and standing applications

Width index	Part No. full set KMA pivoting	Part No. full set KMA locking	Bi [mm]	Width index	Part No. full set KMA pivoting	Part No. full set KMA locking	Bi [mm]
040.	E4.280.040.*.12	E4.281.040.*.12	40	125.	E4.280.125.*.12	E4.281.125.*.12	125
050.	E4.280.050.*.12	E4.281.050.*.12	50	150.	E4.280.150.*.12	E4.281.150.*.12	150
052.	E4.280.052.*.12	E4.281.052.*.12	52	175.	E4.280.175.*.12	E4.281.175.*.12	175
062.	E4.280.062.*.12	E4.281.062.*.12	62	200.	E4.280.200.*.12	E4.281.200.*.12	200
070.	E4.280.070.*.12	E4.281.070.*.12	70	225.	E4.280.225.*.12	E4.281.225.*.12	225
075.	E4.280.075.*.12	E4.281.075.*.12	75	250.	E4.280.250.*.12	E4.281.250.*.12	250
087.	E4.280.087.*.12	E4.281.087.*.12	87	275.	E4.280.275.*.12	E4.281.275.*.12	275
100.	E4.280.100.*.12	E4.281.100.*.12	100	300.	E4.280.300.*.12	E4.281.300.*.12	300

(KMA = polymer metal mounting bracket)

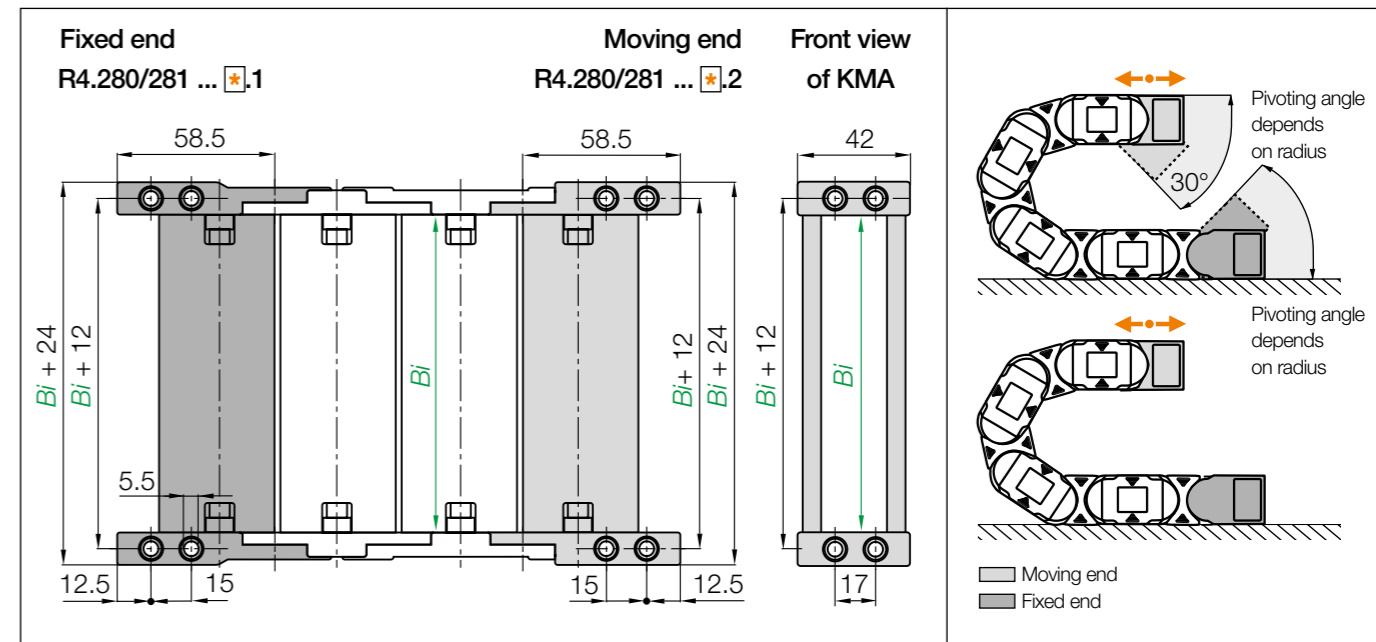

KMA pivoting | Recommended for unsupported and gliding applications
KMA locking | Recommended for vertical hanging and standing applications

Width index	Part No. full set KMA pivoting	Part No. full set KMA locking	Bi [mm]	Width index	Part No. full set KMA pivoting	Part No. full set KMA locking	Bi [mm]
050.	R4.280.050.*.12	R4.281.050.*.12	50	175.	R4.280.175.*.12	R4.281.175.*.12	175
075.	R4.280.075.*.12	R4.281.075.*.12	75	200.	R4.280.200.*.12	R4.281.200.*.12	200
100.	R4.280.100.*.12	R4.281.100.*.12	100	225.	R4.280.225.*.12	R4.281.225.*.12	225
125.	R4.280.125.*.12	R4.281.125.*.12	125	250.	R4.280.250.*.12	R4.281.250.*.12	250
150.	R4.280.150.*.12	R4.281.150.*.12	150	300.	R4.280.300.*.12	R4.281.300.*.12	300

(KMA = polymer metal mounting bracket)

Note: *The e-chains® may end with either an inner or an outer side link. An outer side link should always be the first e-chain® link at the moving end. Please specify the index **1** (for odd) or **2** (for even) depending on an even or odd number of links required.

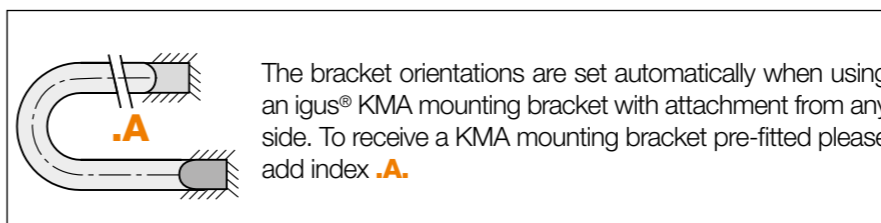
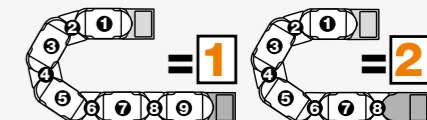

E4.280.100.2.12.A Order example

- Pre-assembled
- Full set
- Even numbers of links
- Width index
- Series

Strain relief e.g. clamps, tiewrap plates, nuggets and clips are available from stock. The complete chainfix range with ordering options ► From page 1392

Previous generation of interior separation with other options ► www.igus.eu/E4.28

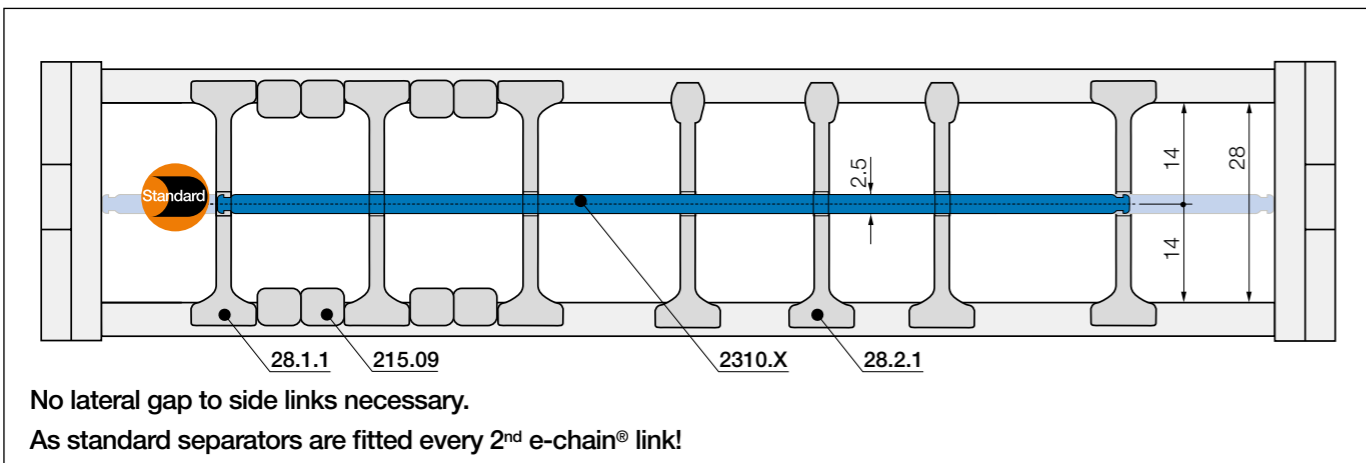

Standard separator, wide base

unassembled	28.1
assembled	28.1.1

Standard - for any application
Separator with a wide base for maximum holding force.

Separator, narrow top

unassembled	28.2
assembled	28.2.1

For even faster installation
Wide on one side for high holding force, narrow on opposite side for easy cable fitting.

Spacer for e-chains®

unassembled	205.09
assembled	215.09

Spacer
Separators can be fixed in position using spacers. The available interior height is reduced by 2mm per spacer (4mm when spacers are fitted on both sides). To avoid this, the parts can also be installed on the outside of the opening crossbar.

Shelf, lockable

unassembled	2300.X
assembled	2310.X

Horizontal separation
Full-width shelf locks securely into separators at both ends, giving a fixed width. Can be used as full-width or partial shelf.

Shelves Width = X [mm]	X [mm]		X [mm]		X [mm]				
	unassembled	assembled	unassembled	assembled	unassembled	assembled			
	015	2300.015	2310.015	060	2300.060	2310.060	087	2300.087	2310.087
	025	2300.025	2310.025	062	2300.062	2310.062	090	2300.090	2310.090
	030	2300.030	2310.030	065	2300.065	2310.065	100	2300.100	2310.100
	038	2300.038	2310.038	070	2300.070	2310.070	103	2300.103	2310.103
	040	2300.040	2310.040	075	2300.075	2310.075	110	2300.110	2310.110
	050	2300.050	2310.050	077	2300.077	2310.077	120	2300.120	2310.120
	057	2300.057	2310.057	080	2300.080	2310.080	125	2300.125	2310.125

Separator with integrated strain relief teeth

- Can be integrated into the mounting bracket or placed at any point
 - Combines strain relief and interior separation, for restricted space conditions
 - Strain relief separator is easy to assemble without any screws
- Part No. 28.Z (e-chain®) / Part No. 28.ZT (e-tube) - more information ► From page 1424

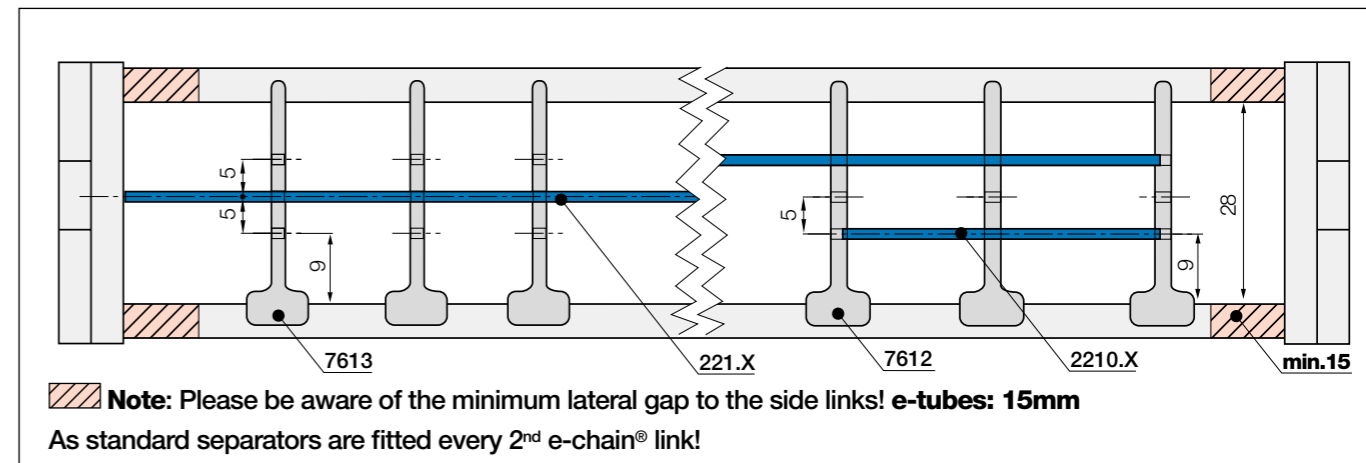

Slotted separator

unassembled	7603
assembled	7613

Option 1 | Full-width shelves
Slotted separator
For a vertical subdivision. The slot allows basic vertical/horizontal shelving arrangements.

Full-width shelf for e-tubes

unassembled	220.X
assembled	221.X

Full-width shelf
This option is for applications with many small cables with similar diameters. For full-width separation.

Full-width shelves Width = X [mm]	X [mm]		X [mm]		X [mm]		X [mm]		
	unassembled	assembled	unassembled	assembled	unassembled	assembled	unassembled	assembled	
	040	220.40	221.40	075	220.75	221.75	150	220.150	221.150
	050	220.50	221.50	087	220.87	221.87	175	220.175	221.175
	062	220.62	221.62	100	220.100	221.100	200	220.200	221.200
	070	220.70	221.70	125	220.125	221.125			

Slotted separator

unassembled	7602
assembled	7612

Option 2 | Shelves
Slotted separator
Allows modular shelving arrangements.

Shelf for e-tubes

unassembled	2200.X
assembled	2210.X

Shelf
For applications involving many cables with different diameters, shelves can be fitted at different heights.

Shelves Width = X [mm]	X [mm]		X [mm]		X [mm]		X [mm]		
	unassembled	assembled	unassembled	assembled	unassembled	assembled	unassembled	assembled	
	018	2200.18	2210.18	043	2200.43	2210.43	088	2200.88	2210.088
	023	2200.23	2210.23	048	2200.48	2210.48	099	2200.99	2210.099
	028	2200.28	2210.28	058	2200.58	2210.58	124	2200.124	2210.124
	033	2200.33	2210.33	068	2200.68	2210.68	149	2200.149	2210.149
	038	2200.38	2210.38	073	2200.73	2210.73			

Aluminium support tray

- Corrosion-resistant and seawater-resistant aluminium rails with adjustable width
- Noise-reducing glide strip integrated as standard
- Easy installation and connection of the e-tube
- Open design - dirt and debris fall through

More information ► From page 1362

**Hot swarf up to +850°C for e-tubes**

- Lids and shelves can repel swarf up to +850°C. Special production option with the igus® material igumid HT
- No hot swarf melting or embedding into the chain

More information ► www.igus.eu/HT

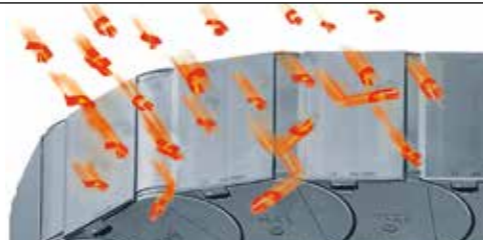
**Reduce assembly time - E4 e-chain® opener**

- e-chain® opener tools for easy opening and closing of e-chains®
- Simple opening and closing of e-chain® crossbars
- Also for use in hard to reach locations
- Significant assembly time reduction

More information ► www.igus.eu/E4savetime



E4.1 e-chains®, supplied as readychains®, reliably supply power and data to different axes of this machine tool

E4.1 | Series E4.32·H4.32·R4.32 | Product range

Strong due to undercut design, medium inner height

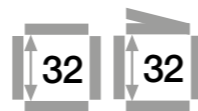

e-chains® | Series E4.32 | Crossbars every link (crossbars removable along the inner and outer radius)
e-chains® | Series H4.32 | Crossbars every 2nd link (crossbars removable along the inner and outer radius)
e-tubes | Series R4.32 | Fully enclosed (lids openable along the outer radius, from one side)

Part No.	Bi	Ba	E4.32	H4.32	R4.32	Part No.	Bi	Ba	E4.32	H4.32	R4.32
e-chains® / e-tubes	[mm]	[mm]	[kg/m]	[kg/m]	[kg/m]	e-chains® / e-tubes	[mm]	[mm]	[kg/m]	[kg/m]	[kg/m]
E4.▲ H4. R4.1) 32.05. R.0	50	73	≈ 1.68	≈ 1.62	≈ 1.83	E4. H4. - 32.212. R.0	212	236	≈ 2.68	≈ 2.12	-
E4.▲ H4. - 32.06. R.0	68	91	≈ 1.81	≈ 1.68	-	E4. H4. - 32.23. R.0	225	248	≈ 2.78	≈ 2.17	-
E4.▲ H4. R4. 32.07. R.0	75	98	≈ 1.85	≈ 1.70	≈ 2.11	E4. H4. - 32.237. R.0	237	261	≈ 2.81	≈ 2.18	-
E4.▲ H4. - 32.087. R.0	87	110	≈ 1.92	≈ 1.73	-	E4. H4. R4. 32.25. R.0	250	273	≈ 2.95	≈ 2.25	≈ 4.15
E4. H4. - 32.097. R.0	97	120	≈ 1.98	≈ 1.76	-	E4. H4. - 32.262. R.0	262	286	≈ 3.03	≈ 2.29	-
E4.▲ H4. R4. 32.10. R.0	100	123	≈ 2.00	≈ 1.78	≈ 2.33	E4. H4. - 32.28. R.0	275	298	≈ 3.10	≈ 2.33	-
E4. H4. R4. 32.11. R.0	108	131	≈ 2.06	≈ 1.80	≈ 2.39	E4. H4. - 32.29. R.0	287	311	≈ 3.14	≈ 2.34	-
E4. H4. - 32.112. R.0	112	136	≈ 2.07	≈ 1.81	-	E4. H4. R4. 32.30. R.0	300	323	≈ 3.27	≈ 2.41	≈ 4.69
E4. H4. R4. 32.12. R.0	125	148	≈ 2.18	≈ 1.87	≈ 2.57	E4. H4. - 32.312. R.0	312	336	≈ 3.29	≈ 2.42	-
E4. H4. - 32.137. R.0	137	161	≈ 2.24	≈ 1.89	-	E4. H4. - 32.325. R.0	325	348	≈ 3.39	≈ 2.47	-
E4.▲ H4. R4. 32.15. R.0	150	173	≈ 2.33	≈ 1.94	≈ 2.84	E4. H4. - 32.337. R.0	337	361	≈ 3.45	≈ 2.50	-
E4. H4. - 32.162. R.0	162	186	≈ 2.36	≈ 1.95	-	E4. H4. - 32.350. R.0	350	373	≈ 3.68	≈ 2.61	-
E4. H4. R4. 32.17. R.0	168	191	≈ 2.44	≈ 1.99	≈ 3.00	E4. H4. - 32.362. R.0	362	386	≈ 3.78	≈ 2.66	-
E4.▲ H4. - 32.18. R.0	175	198	≈ 2.46	≈ 2.00	-	E4. H4. - 32.375. R.0	375	398	≈ 3.85	≈ 2.70	-
E4. H4. - 32.187. R.0	187	211	≈ 2.51	≈ 2.03	-	E4. H4. - 32.387. R.0	387	411	≈ 3.92	≈ 2.73	-
E4.▲ H4. R4. 32.20. R.0	200	223	≈ 2.63	≈ 2.09	≈ 3.35	E4. H4. - 32.400. R.0	400	423	≈ 3.98	≈ 2.77	-

▲ ESD version (Electro Static Discharge) available from stock. More information ▶ From page 142

1) Lid removable, non-openable *Radius not available for e-tubes

Available bend radii

R [mm] | 063* | 075* | 100* | 125 | 150 | 175 | 200 | 220 | 250 | 300 |

Complete Part No. with required radius (R). Example:

E4.32.30.300.0 = crossbars every link / H4.32.30.300.0 = crossbars every 2nd link / R4.32.30.300.0 = fully enclosed

ESD - many sizes from stock

- Standardised product made from igumid ESD
- ESD material tested for over 10 million cycles for the toughest requirements
- Short delivery times including mounting brackets and interior separation; 24hrs, from stock

More information and the complete product range

▶ From page 142 or at ▶ www.igus.eu/esd



E4.1 | E4.32·H4.32·R4.32 | Installation dimensions

Unsupported applications | Short travels

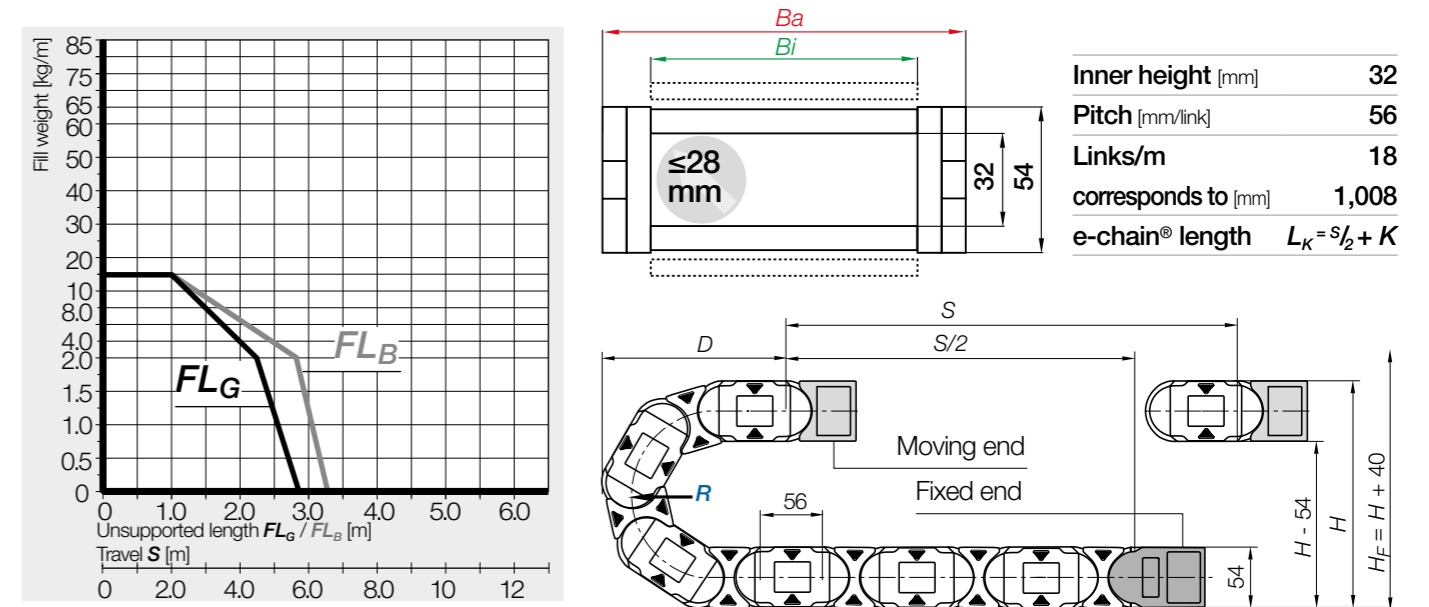
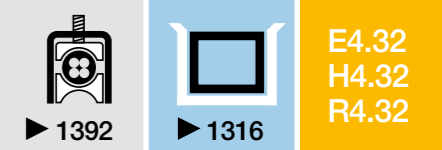

R	063*	075*	100*	125	150	175	200	220	250	300
H ⁺²⁰	180	204	254	304	354	404	454	494	554	654
D	174	186	211	236	261	286	311	331	361	411
K	310	350	430	505	585	665	745	805	900	1,055

The required clearance height: $H_F = H + 40\text{mm}$ (with 2.0kg/m fill weight)

*Radius not available for e-tubes

Gliding applications | For travel lengths from 10m to max. 200m

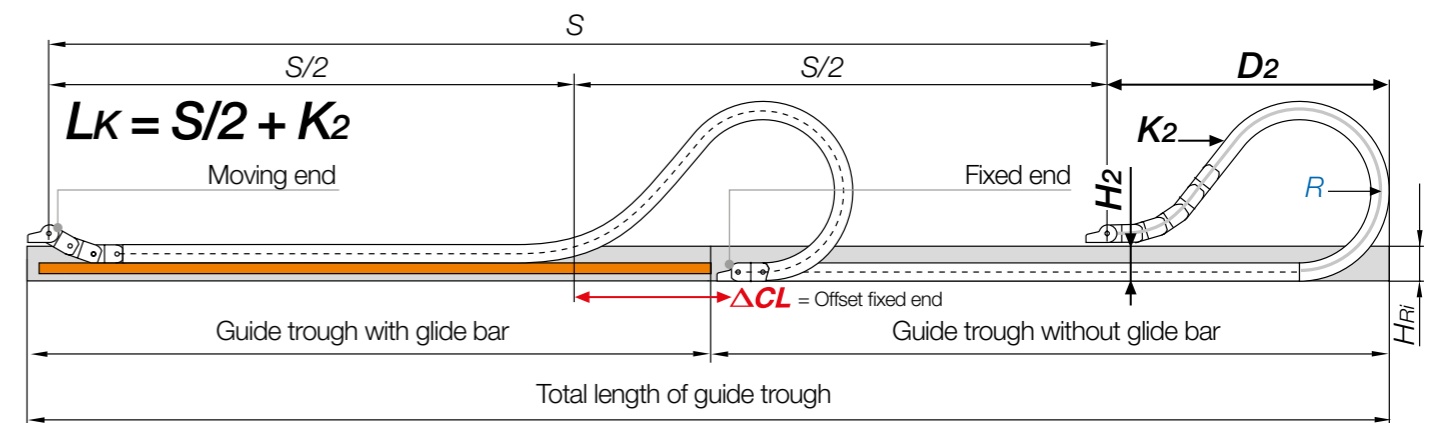

Note: We recommend the project planning of such a system to be carried out by igus®.

In case of travels between 7 and 10m we recommend an e-chain® with a longer unsupported length.

R	063*	075*	100*	125	150	175	200	220	250	300
H ₂	126	150	166	166	166	166	166	166	166	166
D ₂ ⁺²⁵	146	158	370	470	500	655	770	900	930	1,100
K ₂	310	350	616	784	896	1,120	1,288	1,456	1,568	1,904
ΔCL	-	-	160	210	240	370	460	540	570	690

*Radius not available for e-tubes

E4.1 | e-chains® E4.32-H4.32 | Accessories

KMA mounting brackets | Attachment from any side | Pivoting | Locking

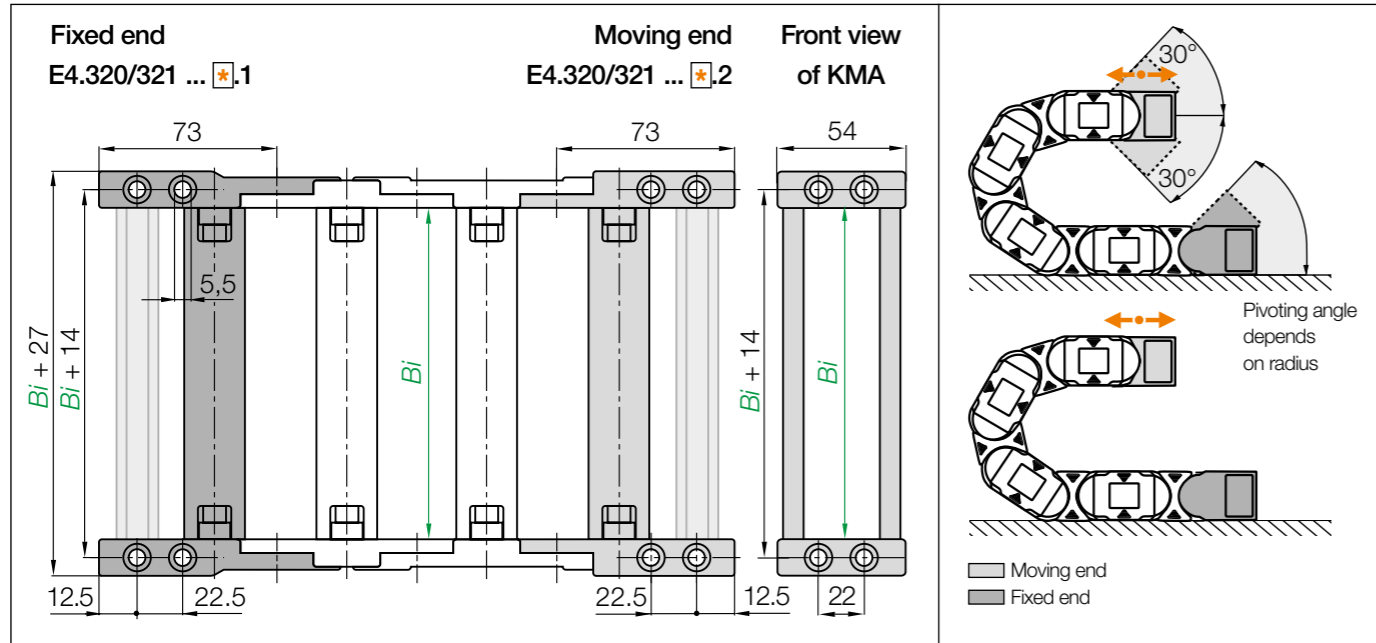

KMA pivoting | Recommended for unsupported and gliding applications
KMA locking | Recommended for vertical hanging and standing applications

Width index	Part No. full set KMA pivoting	Part No. full set KMA locking	Bi [mm]	Width index	Part No. full set KMA pivoting	Part No. full set KMA locking	Bi [mm]
05.	E4.320.05	E4.321.05	50	212.	E4.320.212	E4.321.212	212
06.	E4.320.06	E4.321.06	68	23.	E4.320.23	E4.321.23	225
07.	E4.320.07	E4.321.07	75	237.	E4.320.237	E4.321.237	237
087.	E4.320.087	E4.321.087	87	25.	E4.320.25	E4.321.25	250
09.	E4.320.097	E4.321.097	97	262.	E4.320.262	E4.321.262	262
10.	E4.320.10	E4.321.10	100	28.	E4.320.28	E4.321.28	275
11.	E4.320.11	E4.321.11	108	29.	E4.320.29	E4.321.29	287
112.	E4.320.112	E4.321.112	112	30.	E4.320.30	E4.321.30	300
12.	E4.320.12	E4.321.12	125	312.	E4.320.312	E4.321.312	312
137.	E4.320.137	E4.321.137	137	325.	E4.320.325	E4.321.325	325
15.	E4.320.15	E4.321.15	150	337.	E4.320.337	E4.321.337	337
162.	E4.320.162	E4.321.162	162	350.	E4.320.350	E4.321.350	350
17.	E4.320.17	E4.321.17	168	362.	E4.320.362	E4.321.362	362
18.	E4.320.18	E4.321.18	175	375.	E4.320.375	E4.321.375	375
187.	E4.320.187	E4.321.187	187	387.	E4.320.387	E4.321.387	387
20.	E4.320.20	E4.321.20	200	400.	E4.320.400	E4.321.400	400

(KMA = polymer metal mounting bracket) For the C-profile option please add index .C

E4.1 | e-tubes R4.32 | Accessories

KMA mounting brackets | Attachment from any side | Pivoting | Locking

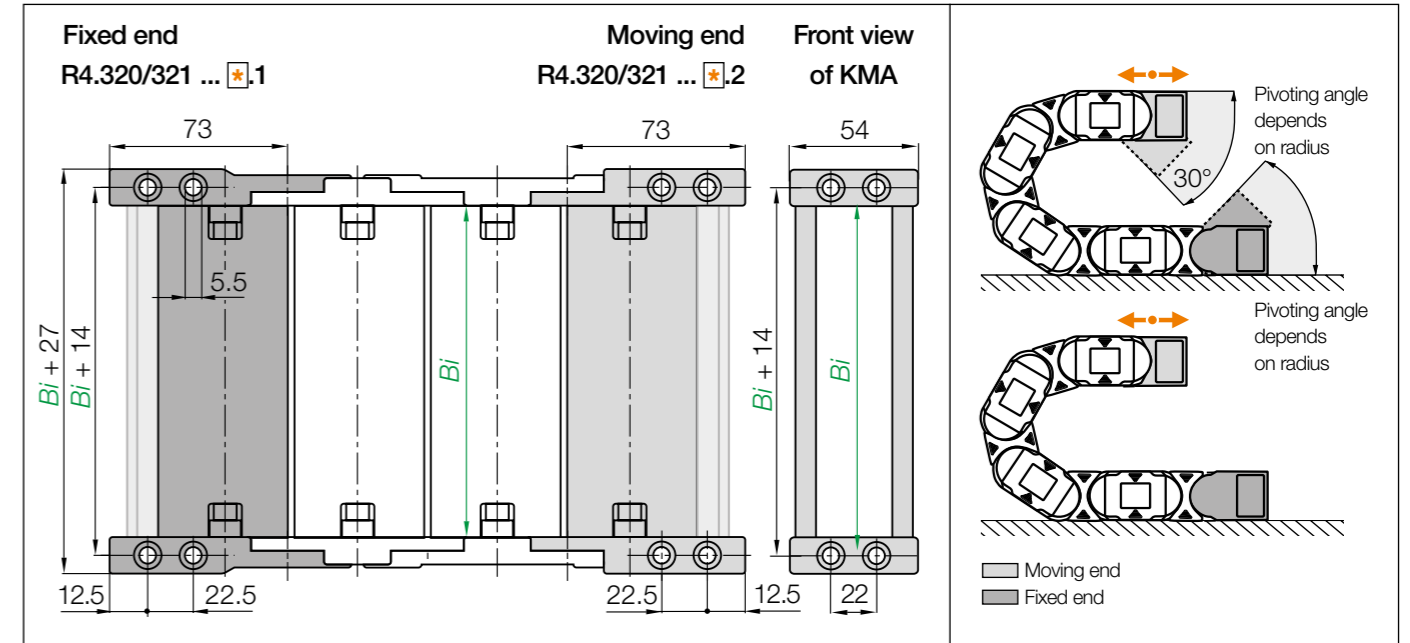

KMA pivoting | Recommended for unsupported and gliding applications
KMA locking | Recommended for vertical hanging and standing applications

Width index	Part No. full set KMA pivoting	Part No. full set KMA locking	Bi [mm]	Width index	Part No. full set KMA pivoting	Part No. full set KMA locking	Bi [mm]
05.	R4.320.05	R4.321.05	50	15.	R4.320.15	R4.321.15	150
07.	R4.320.07	R4.321.07	75	17.	R4.320.17	R4.321.17	168
10.	R4.320.10	R4.321.10	100	20.	R4.320.20	R4.321.20	200
11.	R4.320.11	R4.321.11	108	25.	R4.320.25	R4.321.25	250
12.	R4.320.12	R4.321.12	125	30.	R4.320.30	R4.321.30	300

(KMA = polymer metal mounting bracket) For the C-profile option please add index .C

Note: The e-chains® may end with either an inner or an outer side link. An outer side link should always be the first e-chain® link at the moving end. Please specify the index 1 (for odd) or 2 (for even) depending on an even or odd number of links required.

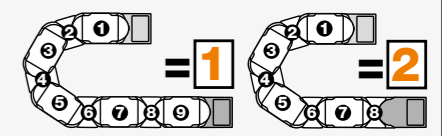

Possible orientations for KMA mounting brackets. For mounting brackets pre-fitted **without C-profile**, please attach index **.A**. For types pre-fitted **with C-profile**, please attach index **.A1, .A2, .A3 or .A4**.

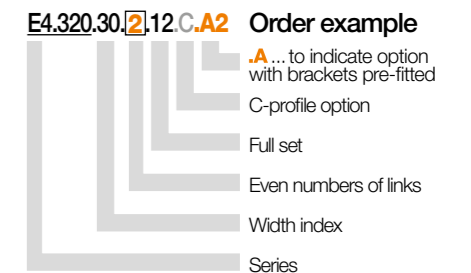

Strain relief e.g. clamps, tiewrap plates, nuggets and clips are available from stock. The complete chainfix range with ordering options ► From page 1392

E4.1 | Series E4.32·H4.32·R4.32 | Accessories

Interior separation | Increase cable service life

Previous generation of interior separation with other options ► www.igus.eu/E4.32

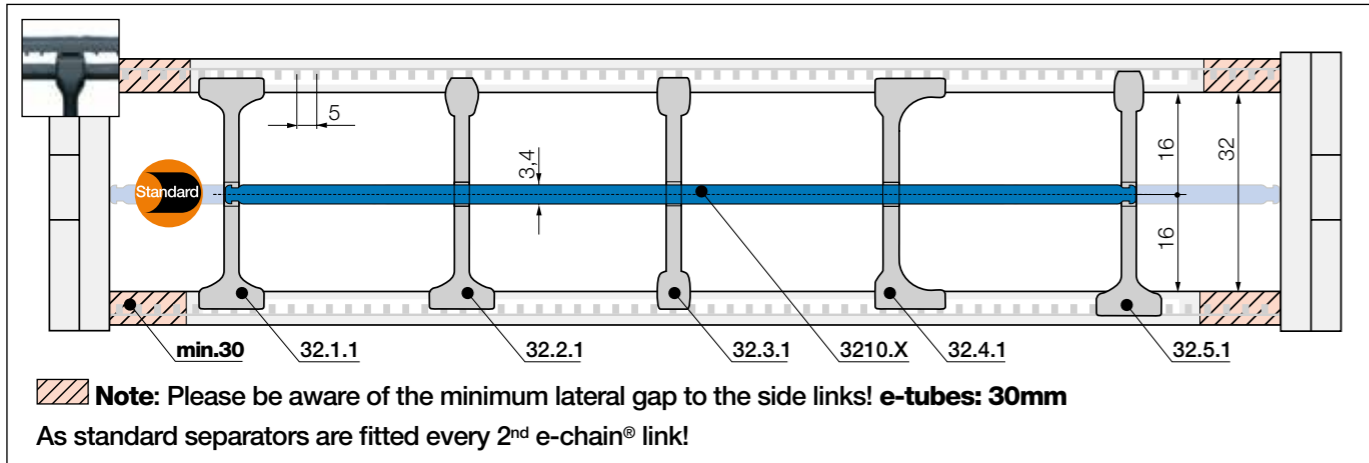

Standard separator, wide base

un assembled	32.1
assembled	32.1.1

Standard - for any application
Separator with a wide base for maximum holding force.

Separator, narrow top

un assembled	32.2
assembled	32.2.1

For even faster installation
Wide on one side for high holding force, narrow on opposite side for easy cable fitting.

Separator, narrow

un assembled	32.3
assembled	32.3.1

For small cables
Separator with a narrow base for a large number of small cables side by side. Saves space.

Separator, asymmetrical

un assembled	32.4
assembled	32.4.1

For side-mounted applications
Asymmetrical separator, for defined gap distance. No additional spacers required.

Notch separator for notched crossbar

un assembled	32.5
assembled	32.5.1

Locks securely in preset increments
Notch separator for exact positioning. Recommended for side-mounted applications.

Shelf, lockable

un assembled	3200.X
assembled	3210.X

Horizontal separation
Full-width shelf locks securely into separators at both ends, giving a fixed width. Can be used as full-width or partial shelf.

Shelves Width = X [mm]	X [mm]		X [mm]		X [mm]		X [mm]	
	un assembled	assembled	un assembled	assembled	un assembled	assembled	un assembled	assembled
050	3200.050	3210.050	125	3200.125	3210.125	225	3200.225	3210.225
075	3200.075	3210.075	150	3200.150	3210.150	250	3200.250	3210.250
100	3200.100	3210.100	175	3200.175	3210.175			
115	3200.115	3210.115	200	3200.200	3210.200			

E4.1 | Series E4.32·H4.32·R4.32 | Further accessories

TUB

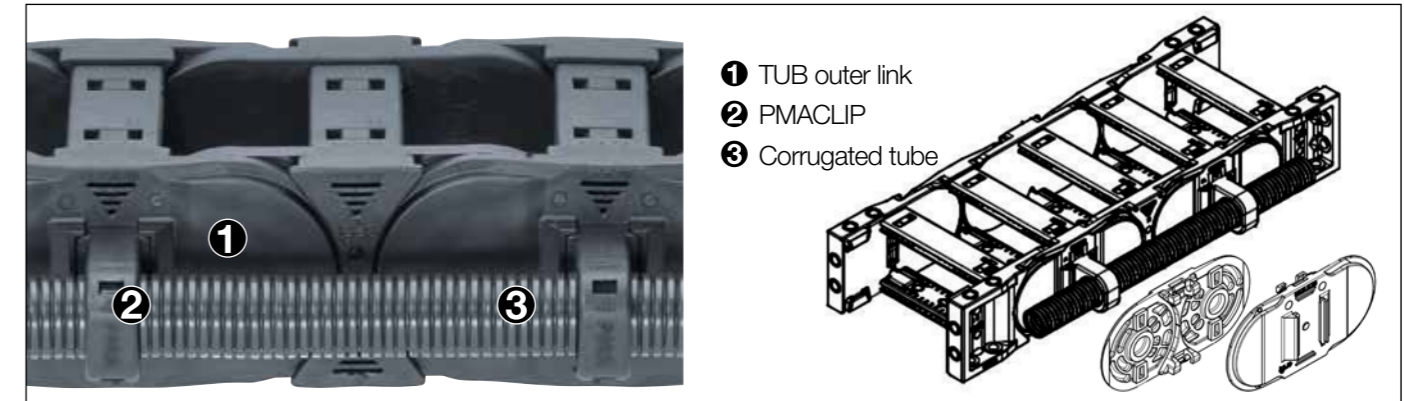

TUB | Safe guidance for corrugated tubes parallel to the e-chain®

- Additional, simple guidance for corrugated tubes on the outside of the e-chain®
- PMACLIP support to be easily clipped on corrugated tubes with nominal widths 07, 10, 12, 17mm
- Easy access to the corrugated tubes, fast replacement of the hoses
- Reduce assembly time and cost - easy to assemble, without any additional screws or tools
- The part number includes the e-chain® with TUB side sections; the PMACLIP support and the hose are ordered separately

Part No. TUB Outer link right*	Part No. TUB Outer link left*	Part No. TUB Outer link at both ends*	For corrugated tube nominal diameter Ø [mm]
E4.32.XXXTUBR.R.0	E4.32.XXXTUBL.R.0	E4.32.XXXTUB.R.0	07 / 10 / 12 / 17

*As viewed from the fixed end

Complete Part No. with the width index **XXX** of **B_i** and the minimum bend radius (**R**). Example:

E4.32.10TUBR.150.0 = with TUB outer sections every 2nd right hand link

Product range | PMACLIP | Support, one-piece, with safety clip

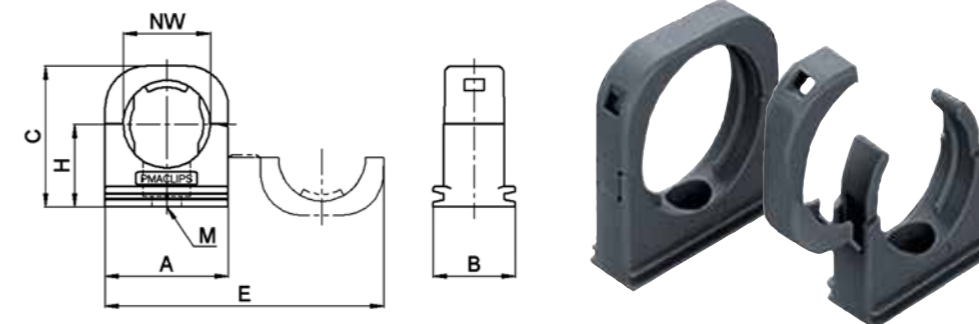

PMACLIP support - one-piece construction with safety clip, suitable for corrugated tubes

Part No.	NW	A	B	C	H	E	M
PMACLIP	Ø [mm]	mm	mm	mm	mm	mm	mm
I-BFH-07-0	07	17.0	20.0	21.5	13.5	40.5	M4
I-BFH-10-0	10	20.5	20.0	24.5	15.5	47.5	M5
I-BFH-12-0	12	24.0	20.0	27.0	16.5	54.5	M5
I-BFH-17-0	17	30.0	20.0	34.0	20.0	68.0	M6

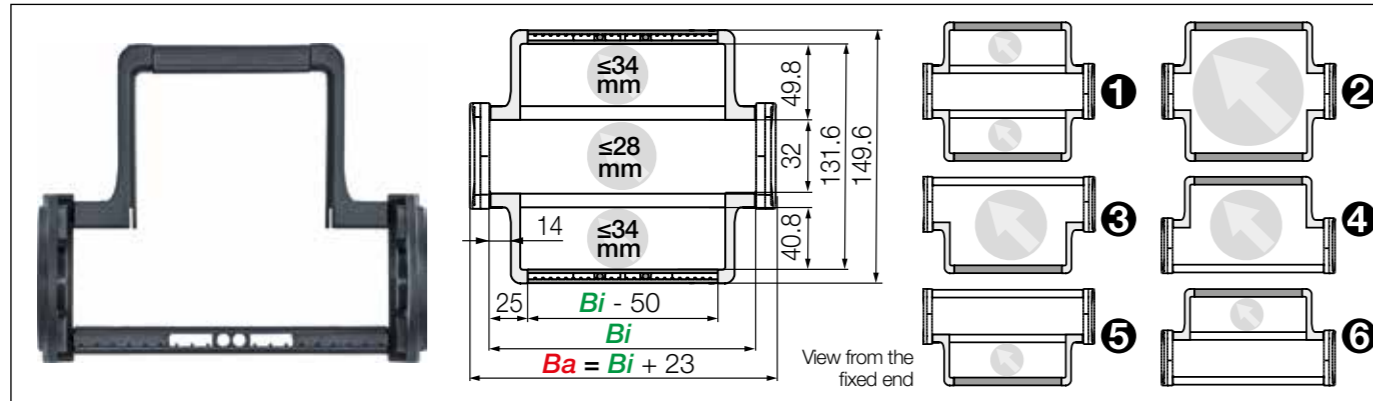

Extender crossbars with flexible width | Safe guiding for large hoses

- For guiding and protecting large hoses
- With mounting for noise dampers
- Cable-friendly design, high crossbar holding force
- The openable extender crossbars can be fitted in different ways and combinations
- Optionally openable along the inner or outer radius

Versions	Hose	Part No.	Part No.
e-chain® with extender crossbar	Ø ≤ [mm]	crossbars every link	crossbars every 2 nd link
❶ Extender crossbar and standard crossbar alternating along the inner and outer radius ¹⁾	34	E4.32.XXXHB50.R.0	-
❷ Extender crossbar on both sides along the inner and outer radius ²⁾	120	E4.32.XXXB50.R.0	H4.32.XXXB50.R.0 ²⁾
❸ Extender crossbar along the outer radius ³⁾	72	E4.32.XXXBE50.R.0	H4.32.XXXBE50.R.0 ²⁾
❹ Extender crossbar along the inner radius ²⁾	72	E4.32.XXXBZ50.R.0	H4.32.XXXBZ50.R.0 ²⁾
❺ Extender crossbar and standard crossbar alternating along the outer radius ³⁾	34	E4.32.XXXHBE50.R.0	-
❻ Extender crossbar and standard crossbar alternating along inner radius ¹⁾	34	E4.32.XXXHBZ50.R.0	-

1) Minimum bend radius: R 125 2) Minimum bend radius: R 150 3) Minimum bend radius: R 063

Bi [mm] Available inner widths

| 100 | 125 | 137 | 150 | 162 | 175 | 187 | 200 | 212 | 225 | 237 | 250 |
| 262 | 275 | 287 | 300 | 312 | 325 | 337 | 350 | 362 | 375 | 387 | 400 |

Part number with the width index XXX of the Bi and the radius (R) supplement e.g. E4.32.10B50.150.0 = Bi 100 / e-chain® with crossbars every link / extender crossbars from both sides along the inner and outer radius / bend radius (R) 150



The E4.1 can be fitted with openable extender crossbars, which increase the size of the interior of the e-chain®. Crossbars can be fitted in various ways: from one or both sides, alternating with standard crossbars and or any combination

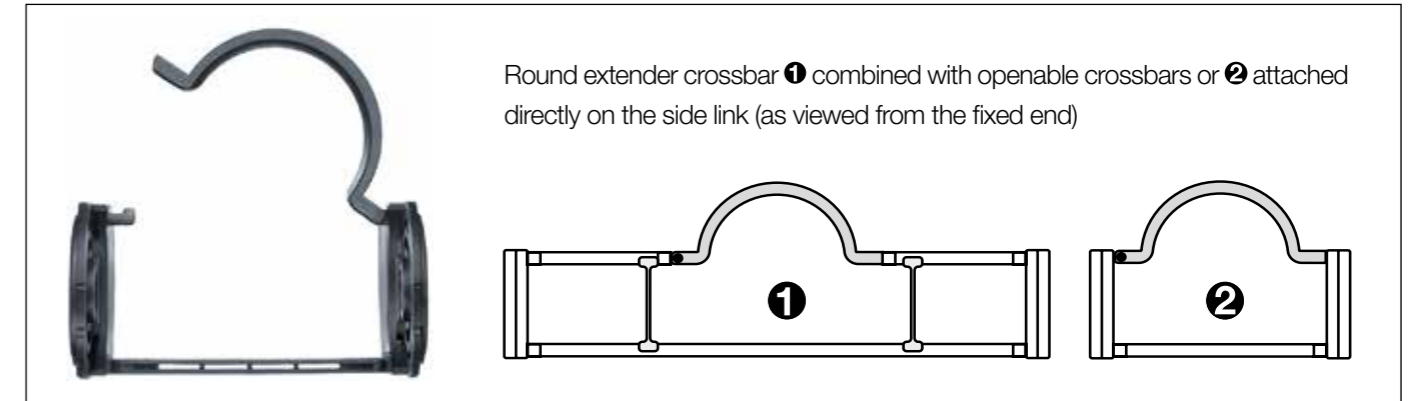

Extender crossbars with fixed width | Safe guiding for large hoses

- Suitable for hoses with a maximum outer diameter of 105mm
- Option ❶ extender crossbars with fixed width to combine with openable crossbars
- Option ❷ extender crossbars with fixed width attached directly on the side link
- Optionally openable along the inner "Z" or the outer radius "E"
- Gliding with crossbars assembled along the outer radius and a special guide trough

Part No. extender crossbar with fixed width, as individual parts	Hose	Extender crossbar shape	❷ Fitted to side link	❶ Combine with openable crossbars
	Ø ≤ [mm]			
385.15RHD115	105	O round	No	Yes
385.18RD115	105	O round	Yes	No

Order example: ❶ combined with openable crossbars

To receive extender crossbar RHD115 pre-fitted along the outer radius of the-chain®, please add index E: E4.32.10/15RHDE115/10.R.0

To receive extender crossbar RHD115 pre-fitted along the inner radius of the-chain®, please add index Z: E4.32.10/15RHDZ115/10.R.0

Order example: ❷ fitted to side link

To receive extender crossbar RD115 pre-fitted along the outer radius of the-chain®, please add index E: E4.32.18RDE115.R.0

To receive extender crossbar RD115 pre-fitted along the inner radius of the-chain®, please add index Z: E4.32.18RDZ115.R.0

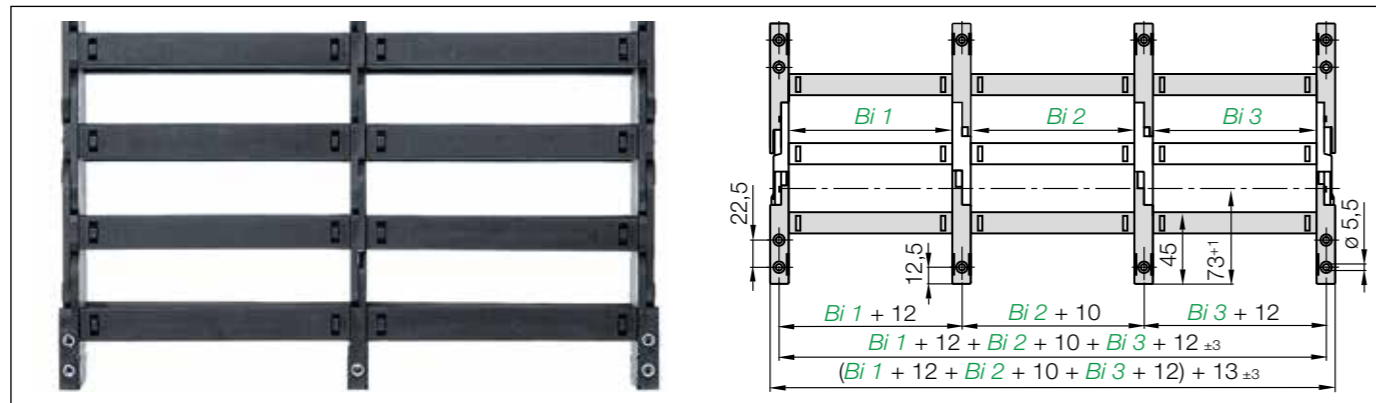

Extension links | For extremely wide e-chains® up to 3.0m

- Virtually unlimited side-by-side extension
- For extremely wide e-chains® up to 3000mm
- Unsupported length FL_G max. can be increased when heavy fill weights are required
- e-chains® and e-tubes can be combined
- Attached with KMA or steel mounting brackets

Part No.	Part No.	Part No.
Extension link e-chain®	Extension link e-tube	Extension link as an individual part
E4.32.Bi1/Bi2/Bi3.R.0	R4.32.Bi1/Bi2/Bi3.R.0	284.R.

Complete Part No. with the width index *Bi1/Bi2/Bi3/etc.* and the radius (*R*). Example: E4.32.10/20/10.200.0

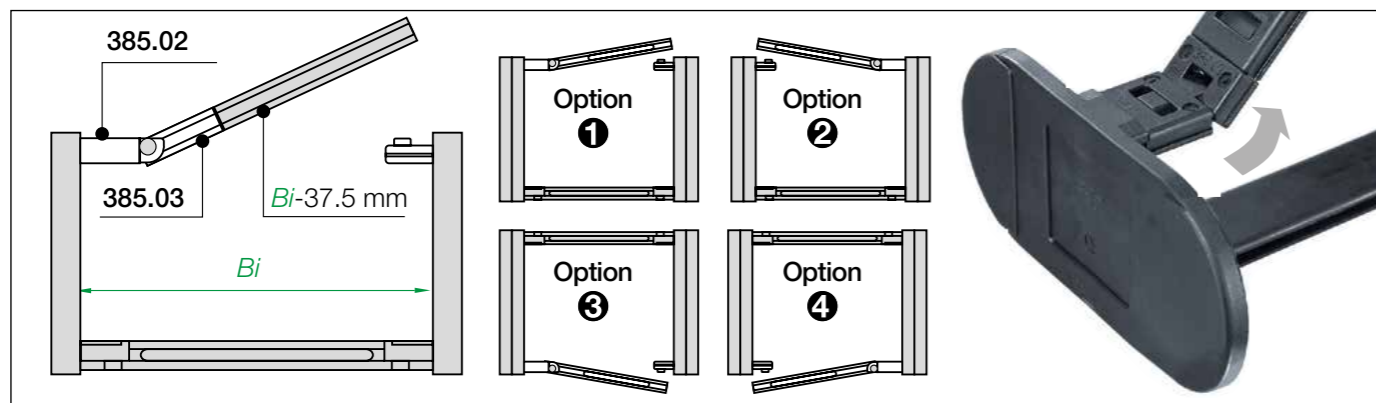

Hinged crossbars | Swivel clip | Openable crossbar remains attached to the e-chain®

- When opening crossbars must remain attached to the e-chain®
- Hinged crossbars consist of a swivel clip and a shortened crossbar
- Openable crossbar (shortened): $Bi-37.5$ mm (smallest inner width $Bi = 87.5$)
- Please consult igus® for assistance with this product

Part No.	Part No.	Part No. openable
e-chain® with hinged crossbar	swivel clip as an individual part	crossbar as an individual part
E4.32.Bi.Z.R.0	385.02	385.03

Complete Part No. with the width index *Bi*, the index *Z* for the required option and the radius (*R*). Example: E4.32.137.1.200.0

Aluminium support tray

- Corrosion-resistant and seawater-resistant aluminium rails with adjustable width
 - Noise-reducing glide strip integrated as standard
 - Easy installation and connection of the e-tube
 - Open design - dirt and debris fall through
- More information ► From page 1362



Hot swarf up to +850°C for e-tubes

- Lids and shelves can repel swarf up to +850°C. Special production option with the igus® material igumid HT
 - No hot swarf melting or embedding into the chain
- More information ► www.igus.eu/HT

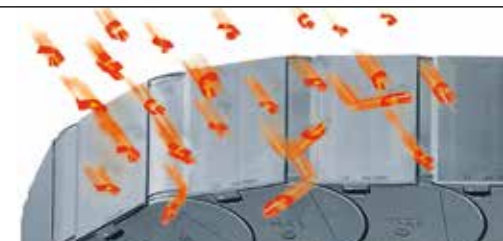

Reduce assembly time - E4 e-chain® opener

- e-chain® opener tools for easy opening and closing of e-chains®
 - Simple opening and closing of e-chain® crossbars
 - Also for use in hard to reach locations
 - Significant assembly time reduction
- More information ► www.igus.eu/E4savetime



Roller crossbars - increase the service life of cables and hoses

- Significantly reduce jacket abrasion of very stiff cables and hoses with rolling contact surfaces equipped with tribo-optimised bearings
 - For sensitive hoses in restricted space
 - Usable along the inner and/or outer radius, retrofit possible
- More information ► upon request



Option: E4Q - the next generation of easy-to-assemble igus® e-chains®

The latest E4Q e-chains® generation combines proven design features of the 12-year old, robust E4.1 e-chains® standard with new bionic design elements and a novel opening mechanism. This gives the E4Q an even longer service life and significantly improved ease of installation.

- Opening and closing completely without tools
 - Greater strength and longer unsupported lengths
 - Lighter e-chain® links due to material saving
 - Optional noise dampening - new system for noise reduction
- More information ► From page 580



E4.1 | Series E4.42·H4.42·R4.42 | Product range

Strong due to undercut design, medium inner height

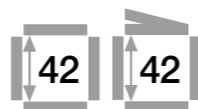

e-chains® | Series E4.42 | Crossbars every link (crossbars removable along the inner and outer radius)
e-chains® | Series H4.42 | Crossbars every 2nd link (crossbars removable along the inner and outer radius)
e-tubes | Series R4.42 | Fully enclosed (lids openable along the outer radius, from one side)

Part No.	Bi	Ba	E4.42	H4.42	R4.42	Part No.	Bi	Ba	E4.42	H4.42	R4.42
e-chains® / e-tubes	[mm]	[mm]	[kg/m]	[kg/m]	[kg/m]	e-chains® / e-tubes	[mm]	[mm]	[kg/m]	[kg/m]	[kg/m]
E4.▲ H4. R4.1)42.05. R.0	50	76	≈ 2.10	≈ 2.05	≈ 2.74	E4. H4. - 42.212.R.0	212	239	≈ 2.94	≈ 2.46	-
E4.▲ H4. R4.1)42.06. R.0	68	94	≈ 2.21	≈ 2.10	-	E4. H4. - 42.23. R.0	225	251	≈ 3.02	≈ 2.51	-
E4.▲ H4. R4. 42.07. R.0	75	101	≈ 2.24	≈ 2.12	≈ 3.05	E4. H4. - 42.237.R.0	237	264	≈ 3.05	≈ 2.52	-
E4.▲ H4. R4. 42.087.R.0	87	114	≈ 2.30	≈ 2.15	≈ 3.20	E4. H4. R4. 42.25. R.0	250	276	≈ 3.16	≈ 2.58	≈ 5.44
E4. H4. - 42.097.R.0	97	123	≈ 2.35	≈ 2.17	-	E4. H4. - 42.262.R.0	262	289	≈ 3.23	≈ 2.61	-
E4.▲ H4. R4. 42.10. R.0	100	126	≈ 2.37	≈ 2.18	≈ 3.34	E4. H4. - 42.28. R.0	275	301	≈ 3.29	≈ 2.64	-
E4. H4. R4. 42.11. R.0	108	134	≈ 2.42	≈ 2.20	≈ 3.39	E4. H4. - 42.29. R.0	287	314	≈ 3.32	≈ 2.65	-
E4. H4. - 42.112.R.0	112	139	≈ 2.43	≈ 2.21	-	E4. H4. R4. 42.30. R.0	300	326	≈ 3.42	≈ 2.71	≈ 6.09
E4. H4. R4. 42.12. R.0	125	151	≈ 2.52	≈ 2.26	≈ 3.58	E4. H4. - 42.312.R.0	312	339	≈ 3.44	≈ 2.72	-
E4. H4. - 42.137.R.0	137	164	≈ 2.57	≈ 2.28	-	E4. H4. - 42.325.R.0	325	351	≈ 3.53	≈ 2.76	-
E4.▲ H4. R4. 42.15. R.0	150	176	≈ 2.64	≈ 2.32	≈ 3.87	E4. H4. - 42.337.R.0	337	364	≈ 3.58	≈ 2.79	-
E4. H4. - 42.162.R.0	162	189	≈ 2.66	≈ 2.33	-	E4. H4. - 42.350.R.0	350	376	≈ 3.77	≈ 2.88	-
E4. H4. R4. 42.17. R.0	168	194	≈ 2.73	≈ 2.36	≈ 4.10	E4. H4. - 42.362.R.0	362	389	≈ 3.85	≈ 2.92	-
E4.▲ H4. - 42.18. R.0	175	201	≈ 2.75	≈ 2.37	-	E4. H4. - 42.375.R.0	375	402	≈ 3.91	≈ 2.95	-
E4. H4. - 42.187.R.0	187	214	≈ 2.79	≈ 2.39	-	E4. H4. - 42.387.R.0	387	414	≈ 3.97	≈ 2.98	-
E4.▲ H4. R4. 42.20. R.0	200	226	≈ 2.90	≈ 2.44	≈ 4.44	E4. H4. - 42.400.R.0	400	426	≈ 4.02	≈ 3.01	-

▲ ESD version (Electro Static Discharge) available from stock. More information ► From page 142
 ◎ All widths of the E4.42 with crossbars every link are available from stock as RBR version (Reverse Bend Radius) 100/500 and 160/450. More information ► From page 130
 1) Lid removable, non-openable *Radius not available for e-tubes

Available bend radii
 R [mm] | 075* | 100*◎ | 115* | 125 | 150 | 160◎ | 175 | 200 | 250 | 300 | 350 |
 Complete Part No. with required radius (R). Example:
 E4.42.30.300.0 = crossbars every link / H4.42.30.300.0 = crossbars every 2nd link / R4.42.30.300.0 = fully enclosed

ESD - many sizes from stock

- Standardised product made from igumid ESD
 - ESD material tested for over 10 million cycles for the toughest requirements
 - Short delivery times including mounting brackets and interior separation; 24hrs, from stock
- More information and the complete product range ► From page 142



E4.1 | E4.42·H4.42·R4.42 | Installation dimensions

Unsupported applications | Short travels

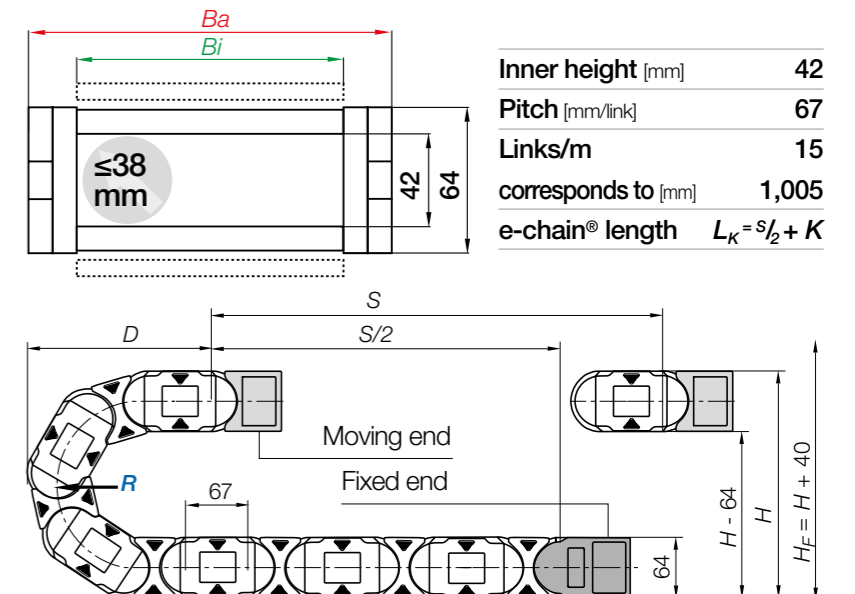
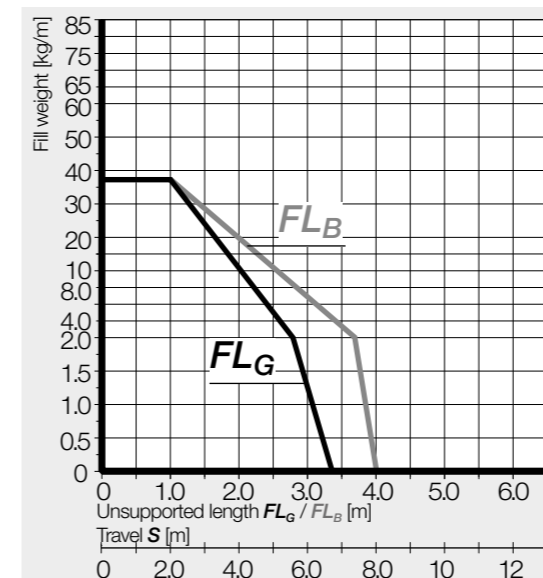
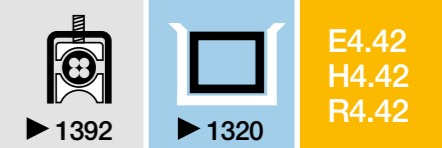

R	075*	100*	115*	125	150	160	175	200	250	300	350
H _{±0.25}	214	264	294	314	364	384	414	464	564	664	764
D	208	233	248	258	283	293	308	333	383	433	483
K	370	450	500	530	610	640	685	765	920	1,080	1,235

The required clearance height: $H_F = H + 40\text{mm}$ (with 3.0kg/m fill weight)

*Radius not available for e-tubes

Gliding applications | For travel lengths from 12m to max. 300m

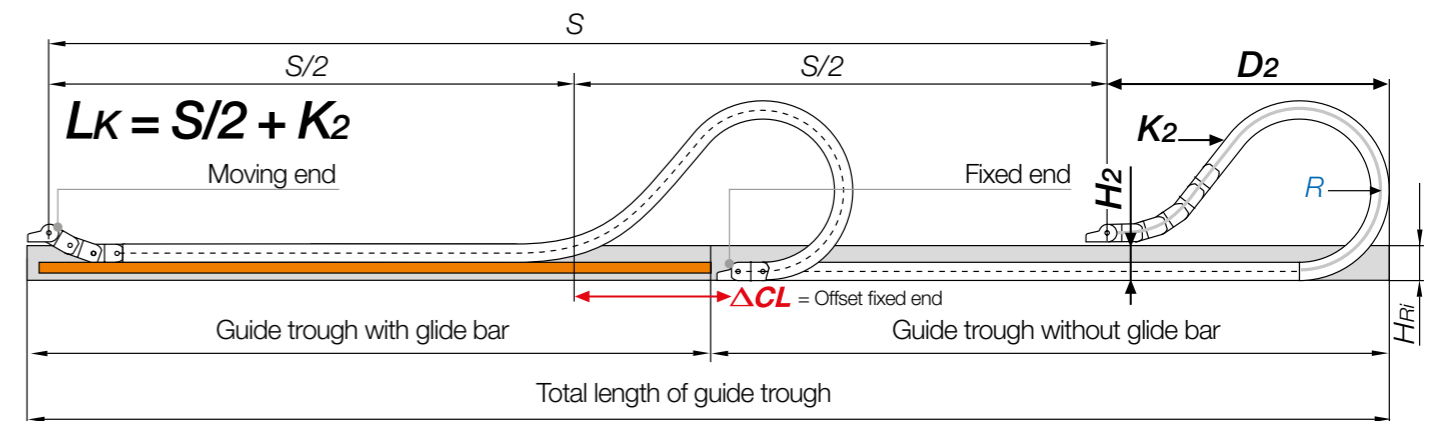

Note: We recommend the project planning of such a system to be carried out by igus®. In case of travels between 8 and 12m we recommend an e-chain® with a longer unsupported length.

R	075*	100*	115*	125	150	160	175	200	250	300	350
H ₂	150	186	186	186	186	186	186	186	186	186	186
D ₂ ⁺²⁵	174	390	435	475	570	623	670	780	1,030	1,150	1,500
K ₂	370	603	737	804	938	1,072	1,139	1,340	1,675	1,943	2,412
ΔCL	-	170	200	230	300	380	380	460	660	730	1,030

*Radius not available for e-tubes

Rotating energy supply systems with Reverse Bend Radius (RBR) - some radii available from stock

- Maximum rotation angle in minimal installation space
 - Minimal friction forces and maximum service life
- More information and the complete product range ► From page 130



E4.1 | e-chains® E4.42-H4.42 | Accessories

KMA mounting brackets | Attachment from any side | Pivoting | Locking

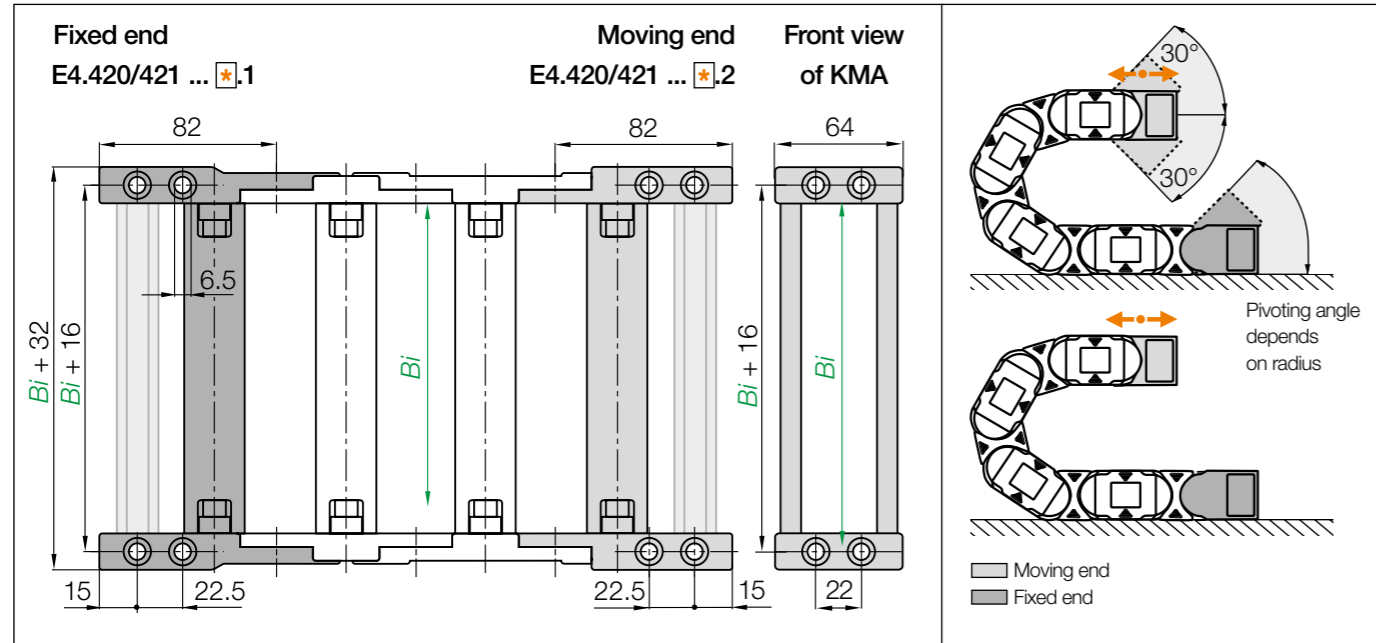

KMA pivoting | Recommended for unsupported and gliding applications
KMA locking | Recommended for vertical hanging and standing applications

Width index	Part No. full set KMA pivoting	Part No. full set KMA locking	Bi [mm]	Width index	Part No. full set KMA pivoting	Part No. full set KMA locking	Bi [mm]
05.	E4.420.05 .12.C	E4.421.05 .12.C	50	212.	E4.420.212 .12.C	E4.421.212 .12.C	212
06.	E4.420.06 .12.C	E4.421.06 .12.C	68	23.	E4.420.23 .12.C	E4.421.23 .12.C	225
07.	E4.420.07 .12.C	E4.421.07 .12.C	75	237.	E4.420.237 .12.C	E4.421.237 .12.C	237
087.	E4.420.087 .12.C	E4.421.087 .12.C	87	25.	E4.420.25 .12.C	E4.421.25 .12.C	250
09.	E4.420.097 .12.C	E4.421.097 .12.C	97	262.	E4.420.262 .12.C	E4.421.262 .12.C	262
10.	E4.420.10 .12.C	E4.421.10 .12.C	100	28.	E4.420.28 .12.C	E4.421.28 .12.C	275
11.	E4.420.11 .12.C	E4.421.11 .12.C	108	29.	E4.420.29 .12.C	E4.421.29 .12.C	287
112.	E4.420.112 .12.C	E4.421.112 .12.C	112	30.	E4.420.30 .12.C	E4.421.30 .12.C	300
12.	E4.420.12 .12.C	E4.421.12 .12.C	125	312.	E4.420.312 .12.C	E4.421.312 .12.C	312
137.	E4.420.137 .12.C	E4.421.137 .12.C	137	325.	E4.420.325 .12.C	E4.421.325 .12.C	325
15.	E4.420.15 .12.C	E4.421.15 .12.C	150	337.	E4.420.337 .12.C	E4.421.337 .12.C	337
162.	E4.420.162 .12.C	E4.421.162 .12.C	162	350.	E4.420.350 .12.C	E4.421.350 .12.C	350
17.	E4.420.17 .12.C	E4.421.17 .12.C	168	362.	E4.420.362 .12.C	E4.421.362 .12.C	362
18.	E4.420.18 .12.C	E4.421.18 .12.C	175	375.	E4.420.375 .12.C	E4.421.375 .12.C	375
187.	E4.420.187 .12.C	E4.421.187 .12.C	187	387.	E4.420.387 .12.C	E4.421.387 .12.C	387
20.	E4.420.20 .12.C	E4.421.20 .12.C	200	400.	E4.420.400 .12.C	E4.421.400 .12.C	400

(KMA = polymer metal mounting bracket) For the C-profile option please add index .C

E4.1 | e-tubes R4.42 | Accessories

KMA mounting brackets | Attachment from any side | Pivoting | Locking

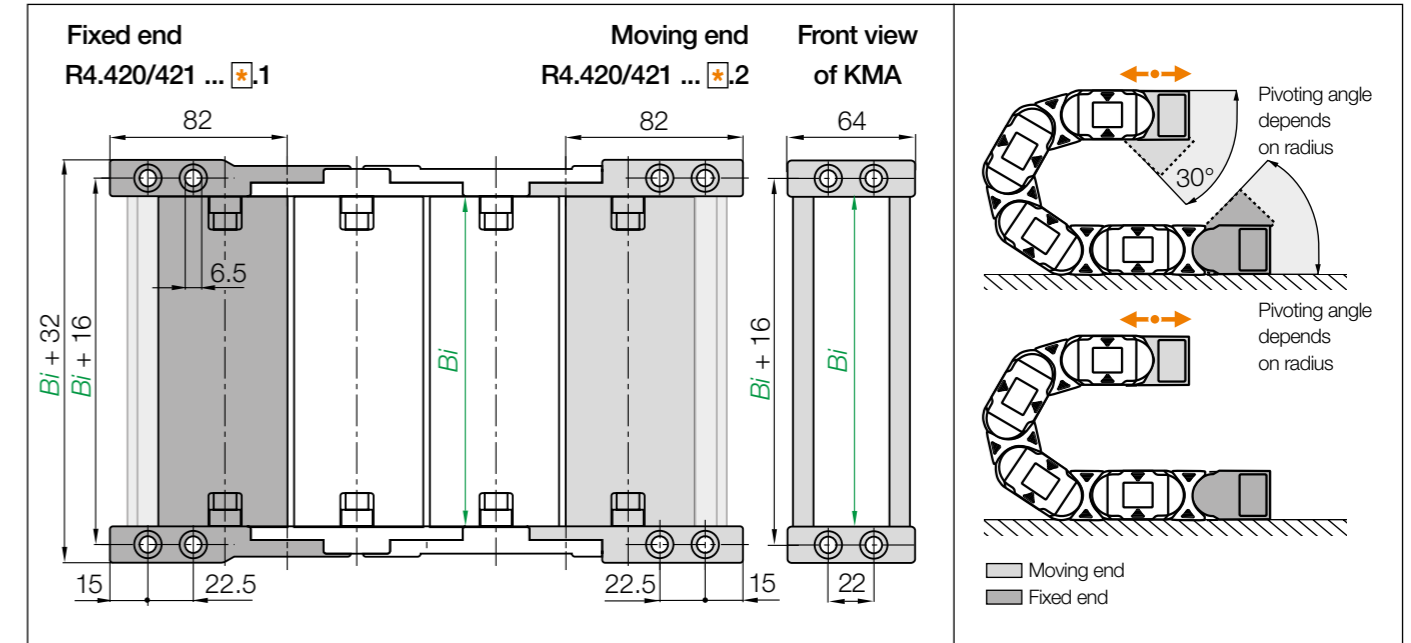

KMA pivoting | Recommended for unsupported and gliding applications
KMA locking | Recommended for vertical hanging and standing applications

Width index	Part No. full set KMA pivoting	Part No. full set KMA locking	Bi [mm]	Width index	Part No. full set KMA pivoting	Part No. full set KMA locking	Bi [mm]
05.	R4.420.05 .12.C	R4.421.05 .12.C	50	12.	R4.420.12 .12.C	R4.421.12 .12.C	125
06.	R4.420.06 .12.C	R4.421.06 .12.C	68	15.	R4.420.15 .12.C	R4.421.15 .12.C	150
07.	R4.420.07 .12.C	R4.421.07 .12.C	75	17.	R4.420.17 .12.C	R4.421.17 .12.C	168
087.	R4.420.087 .12.C	R4.421.087 .12.C	087	20.	R4.420.20 .12.C	R4.421.20 .12.C	200
10.	R4.420.10 .12.C	R4.421.10 .12.C	100	25.	R4.420.25 .12.C	R4.421.25 .12.C	250
11.	R4.420.11 .12.C	R4.421.11 .12.C	108	30.	R4.420.30 .12.C	R4.421.30 .12.C	300

(KMA = polymer metal mounting bracket) For the C-profile option please add index .C

Note: The e-chains® may end with either an inner or an outer side link. An outer side link should always be the first e-chain® link at the moving end. Please specify the index 1 (for odd) or 2 (for even) depending on an even or odd number of links required.

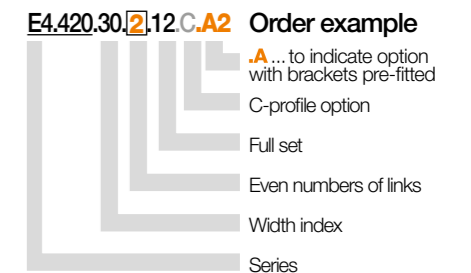
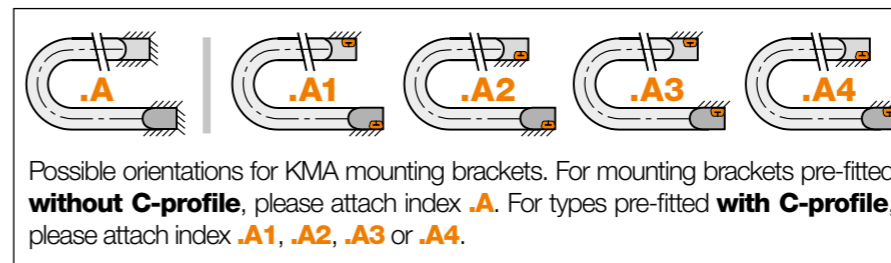
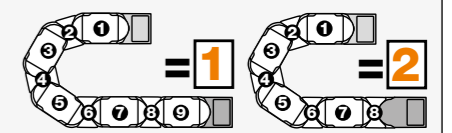

Strain relief e.g. clamps, tie-wrap plates, nuggets and clips are available from stock. The complete chainfix range with ordering options ▶ From page 1392

Previous generation of interior separation with other options ► www.igus.eu/E4.42

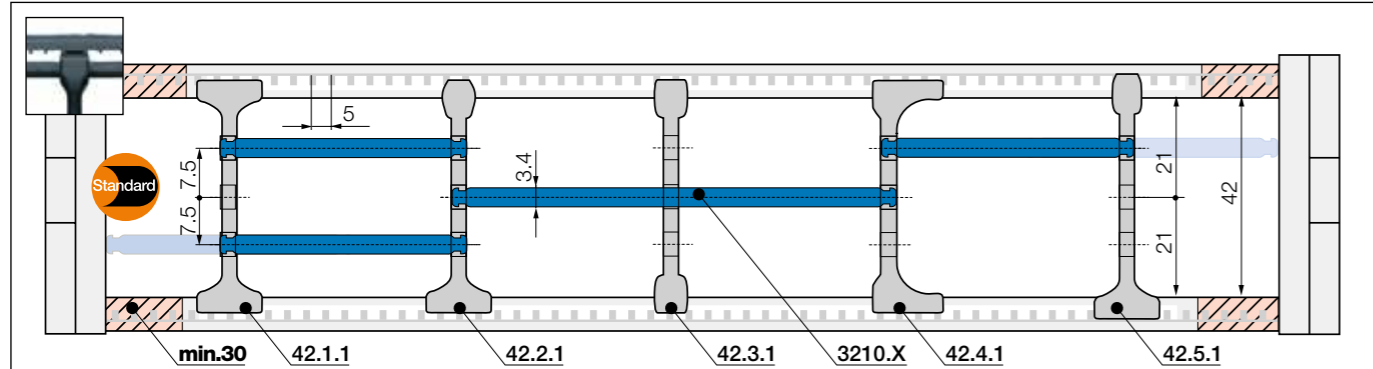

Note: Please be aware of the minimum lateral gap to the side links! **e-tubes: 30mm**
As standard separators are fitted every 2nd e-chain® link!

			Standard separator, wide base
			unassembled 42.1 assembled 42.1.1

Standard - for any application
Separator with a wide base for maximum holding force.

			Separator, narrow top
			unassembled 42.2 assembled 42.2.1

For even faster installation
Wide on one side for high holding force, narrow on opposite side for easy cable fitting.

			Separator, narrow
			unassembled 42.3 assembled 42.3.1

For small cables
Separator with a narrow base for a large number of small cables side by side. Saves space.

			Separator, asymmetrical
			unassembled 42.4 assembled 42.4.1

For side-mounted applications
Asymmetrical separator, for defined gap distance. No additional spacers required.

			Notch separator for notched crossbar
			unassembled 42.5 assembled 42.5.1

Locks securely in preset increments
Notch separator for exact positioning. Recommended for side-mounted applications.

			Shelf, lockable
			unassembled 3200.X assembled 3210.X

Horizontal separation
Full-width shelf locks securely into separators at both ends, giving a fixed width. Can be used as full-width or partial shelf.

Shelves Width = X [mm]	X [mm]	unassembled	assembled	X [mm]	unassembled	assembled	X [mm]	unassembled	assembled
		050	3200.050	3210.050	125	3200.125	3210.125	225	3200.225
	075	3200.075	3210.075	150	3200.150	3210.150	250	3200.250	3210.250
	100	3200.100	3210.100	175	3200.175	3210.175			
	115	3200.115	3210.115	200	3200.200	3210.200			

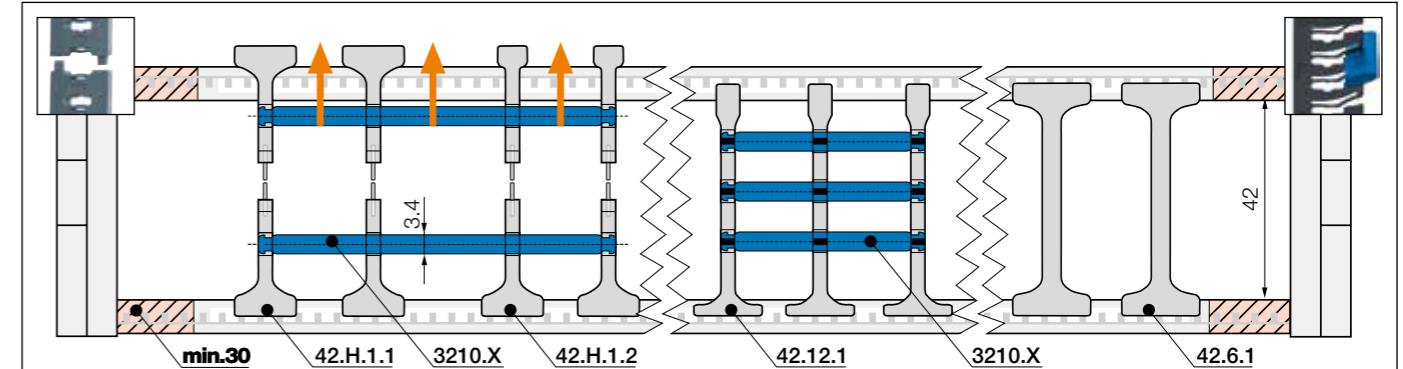

Note: Please be aware of the minimum lateral gap to the side links! **e-tubes: 30mm**
As standard separators are fitted every 2nd e-chain® link!

			Split separator, wide base/top
			unassembled 42.H.1 assembled 42.H.1.1

Split separators
In order to fill e-chains® more easily and effectively, these separators can be split in the middle. This allows easier access to middle shelf partitions. Fast assembly and easy retrofit. 2 types available: with wide or narrow top.

			Split separator, narrow top
			unassembled 42.H.2 assembled 42.H.2.1

			Lean separator¹⁾
			unassembled 42.12 assembled 42.12.1

Lean separators¹⁾
For quick fitting of shelves in several layers.
1) Note: Please combine maximum 4 lean separators with one shelf. Not suitable for side-mounted e-chains®!

With the lean separator you can quickly insert several layers of cables into the e-chain® and reduce the installation time by up to 50%²⁾.

²⁾ Lean interior separation vs. Standard separator - measured on a 4m long e-chain® fitted with 12 cables in the igus® readychain® factory



More interior separation options | Only for e-chains®

			Notch locking separator, lockable for e-chains®
			unassembled 42.6 assembled 42.6.1

Notch locking separator* for increased holding force
Notch locking separators offer higher crossbar opening forces for high humidity and/or large hydraulic hoses. They can be positioned precisely and then locked in position.
*Only suitable for e-chains®

TUB

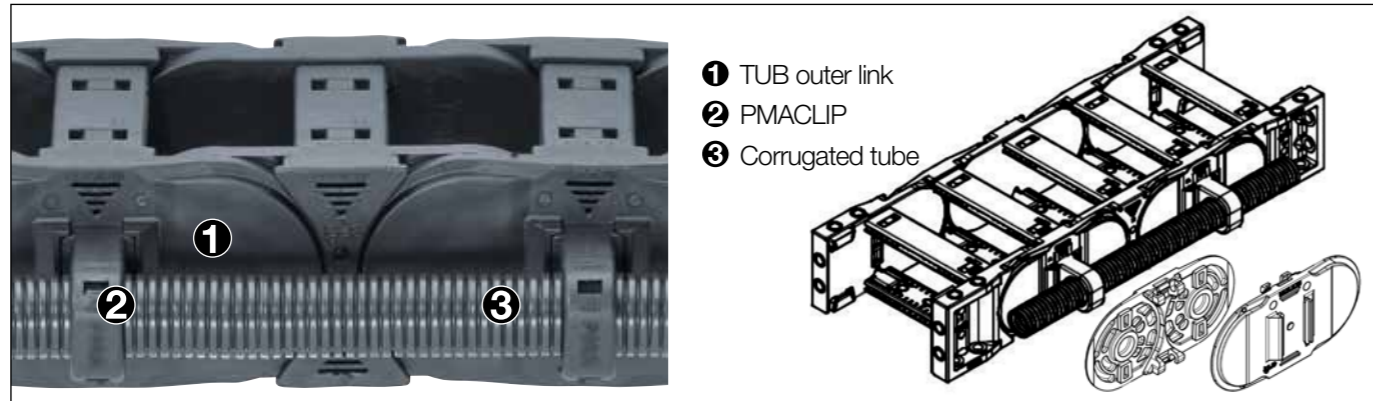

TUB | Safe guidance for corrugated tubes parallel to the e-chain®

- Additional, simple guidance for corrugated tubes on the outside of the e-chain®
- PMACLIP support to be easily clipped on corrugated tubes with nominal widths 07, 10, 12, 17mm
- Easy access to the corrugated tubes, fast replacement of the hoses
- Reduce assembly time and cost - easy to assemble, without any additional screws or tools
- The part number includes the e-chain® with TUB side sections; the PMACLIP support and the hose are ordered separately

Part No. TUB	Part No. TUB	Part No. TUB	For corrugated tube nominal diameter
Outer link right*	Outer link left*	Outer link at both ends*	Ø [mm]
E4.42.XXXTUBR.R.0	E4.42.XXXTUBL.R.0	E4.42.XXXTUB.R.0	07 / 10 / 12 / 17

*As viewed from the fixed end

Complete Part No. with the width index **XXX** of B_i and the minimum bend radius (R). Example:

E4.42.10TUBR.150.0 = with TUB outer sections every 2nd right hand link

Product range | PMACLIP | Support, one-piece, with safety clip

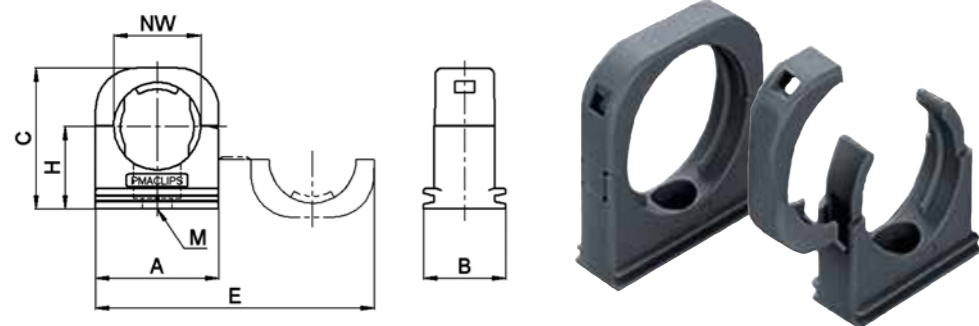

PMACLIP support - one-piece construction with safety clip, suitable for corrugated tubes

Part No.	NW	A	B	C	H	E	M
PMACLIP	Ø [mm]	mm	mm	mm	mm	mm	mm
I-BFH-07-0	07	17.0	20.0	21.5	13.5	40.5	M4
I-BFH-10-0	10	20.5	20.0	24.5	15.5	47.5	M5
I-BFH-12-0	12	24.0	20.0	27.0	16.5	54.5	M5
I-BFH-17-0	17	30.0	20.0	34.0	20.0	68.0	M6

e-chain® with openable extender crossbars

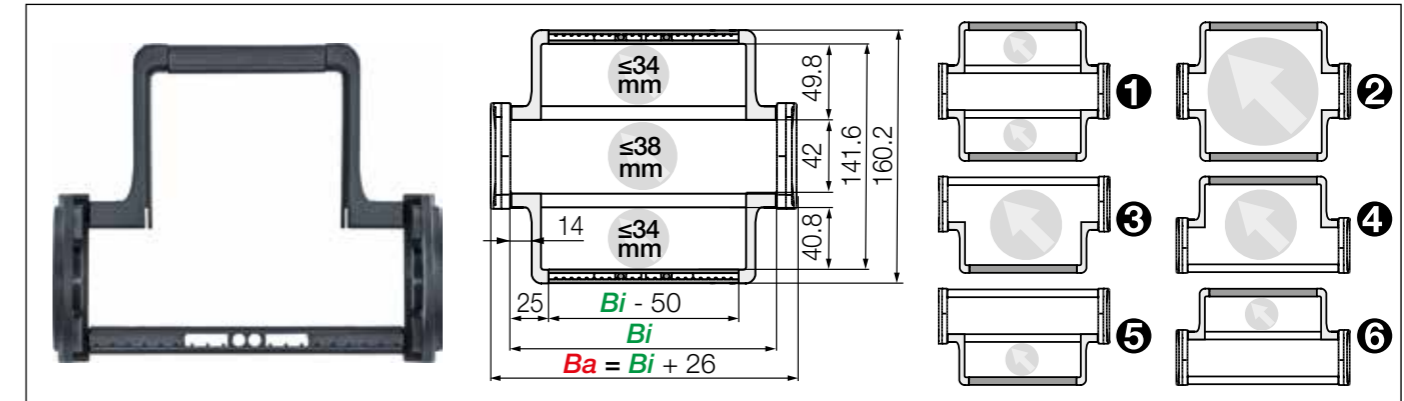

Extender crossbars with flexible width | Safe guiding for large hoses

- For guiding and protecting large hoses
- With mounting for noise dampers
- Cable-friendly design, high crossbar holding force
- The openable extender crossbars can be fitted in different ways and combinations
- Optionally openable along the inner or outer radius

Versions	Hose	Part No.	Part No.
e-chain® with extender crossbar	Ø ≤ [mm]	crossbars every link	crossbars every 2 nd link
1 Extender crossbar and standard crossbar alternating along the inner and outer radius ¹⁾	34	E4.42.XXXHB50.R.0	-
2 Extender crossbar on both sides along the inner and outer radius ²⁾	130	E4.42.XXXB50.R.0	H4.42.XXXB50.R.0 ²⁾
3 Extender crossbar along the outer radius ³⁾	85	E4.42.XXXBE50.R.0	H4.42.XXXBE50.R.0 ²⁾
4 Extender crossbar along the inner radius ²⁾	85	E4.42.XXXBZ50.R.0	H4.42.XXXBZ50.R.0 ²⁾
5 Extender crossbar and standard crossbar alternating along the outer radius ³⁾	34	E4.42.XXXHBE50.R.0	-
6 Extender crossbar and standard crossbar alternating along inner radius ¹⁾	34	E4.42.XXXHBZ50.R.0	-

1) Minimum bend radius: R 125 2) Minimum bend radius: R 150 3) Minimum bend radius: R 075

B_i [mm] Available inner widths

| 100 | 125 | 137 | 150 | 162 | 175 | 187 | 200 | 212 | 225 | 237 | 250 |
| 262 | 275 | 287 | 300 | 312 | 325 | 337 | 350 | 362 | 375 | 387 | 400 |

Part number with the width index **XXX** of the B_i and the radius (R) supplement e.g. E4.42.10B50.150.0 = B_i 100 / e-chain® with crossbars every link / extender crossbars from both sides along the inner and outer radius / bend radius (R) 150



The E4.1 can be fitted with openable extender crossbars, which increase the size of the interior of the e-chain®. Crossbars can be fitted in various ways: from one or both sides, alternating with standard crossbars and or any combination

E4.1 | Series E4.42·H4.42·R4.42 | Further accessories

Extender crossbar with fixed width

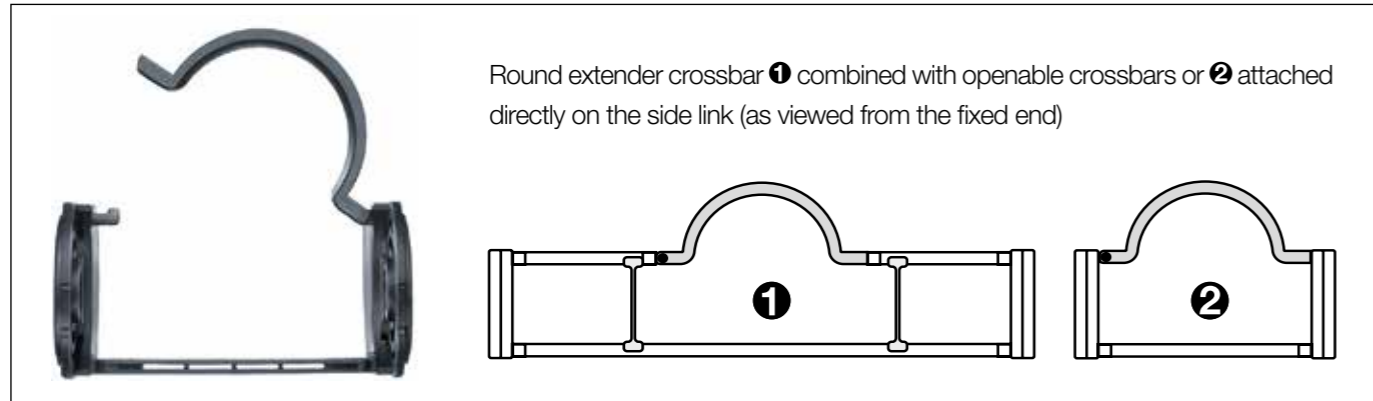

Extender crossbars with fixed width | Safe guiding for large hoses

- Suitable for hoses with a maximum outer diameter of 105mm
- Option ❶ extender crossbars with fixed width to combine with openable crossbars
- Option ❷ extender crossbars with fixed width attached directly on the side link
- Optionally openable along the inner "Z" or the outer radius "E"
- Gliding with crossbars assembled along the outer radius and a special guide trough

Part No. extender crossbar with fixed width, as individual parts	Hose $\varnothing \leq$ [mm]	Extender crossbar shape	❷ Fitted to side link	❶ Combine with openable crossbars
385.15RHD115	105	○ round	No	Yes
385.18RD115	105	○ round	Yes	No

Order example: ❶ combined with openable crossbars

To receive extender crossbar RHD115 pre-fitted along the outer radius of the-chain®, please add index **E**: E4.42.10/15RHDE115/10.R.0

To receive extender crossbar RHD115 pre-fitted along the inner radius of the-chain®, please add index **Z**: E4.42.10/15RHDZ115/10.R.0

Order example: ❷ fitted to side link

To receive extender crossbar RD115 pre-fitted along the outer radius of the-chain®, please add index **E**: E4.42.18RDE115.R.0

To receive extender crossbar RD115 pre-fitted along the inner radius of the-chain®, please add index **Z**: E4.42.18RDZ115.R.0

E4.1 | Series E4.42·H4.42·R4.42 | Further accessories

Extension links | Hinged crossbars | Swivel clip

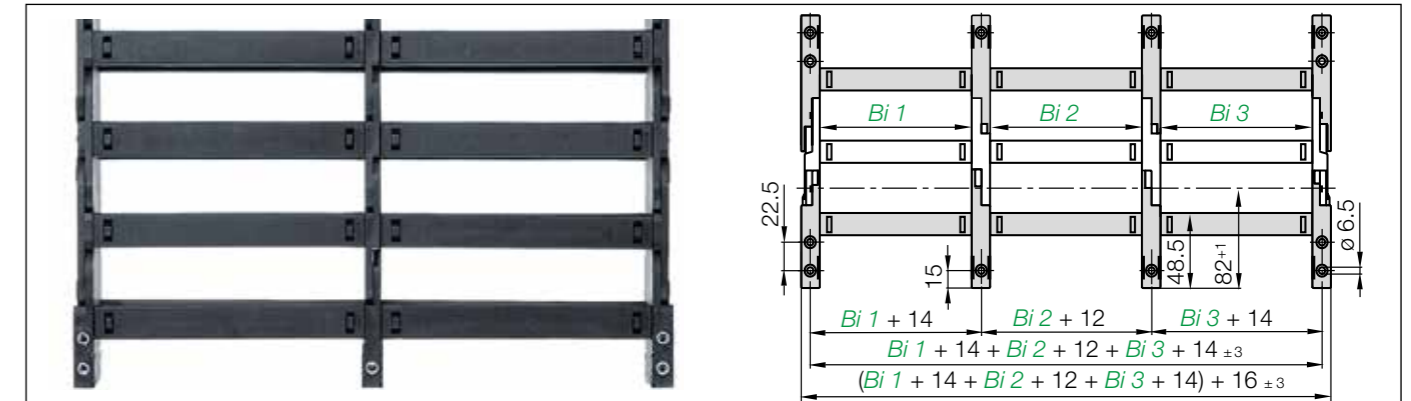

Extension links | For extremely wide e-chains® up to 3.0m

- Virtually unlimited side-by-side extension
- For extremely wide e-chains® up to 3000mm
- Unsupported length FL_G max. can be increased when heavy fill weights are required
- e-chains® and e-tubes can be combined
- Attached with KMA or steel mounting brackets

Part No.	Part No.	Part No.
Extension link e-chain®	Extension link e-tube	Extension link as an individual part
E4.42.Bi1/Bi2/Bi3.R.0	R4.42.Bi1/Bi2/Bi3.R.0	384.R.

Complete Part No. with the width index $Bi1/Bi2/Bi3/etc.$ and the radius (R). Example: E4.42.10/20/10.200.0

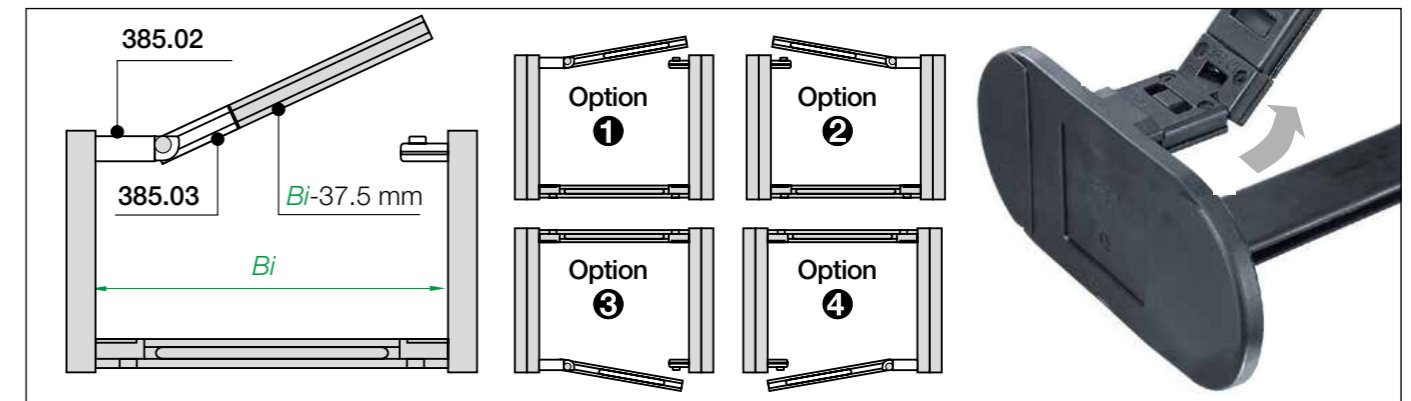

Hinged crossbars | Swivel clip | Openable crossbar remains attached to the e-chain®

- When opening crossbars must remain attached to the e-chain®
- Hinged crossbars consist of a swivel clip and a shortened crossbar
- Openable crossbar (shortened): $Bi-37.5\ mm$ (smallest inner width $Bi = 87.5$)
- Please consult igus® for assistance with this product

Part No.	Part No.	Part No. openable crossbar as an individual part
e-chain® with hinged crossbar	swivel clip as an individual part	
E4.42.Bi.Z.R.0	385.02	385.03

Complete Part No. with the width index Bi , the index Z for the required option and the radius (R). Example: E4.42.137.1.200.0

Steel support tray for support of the lower run

- Simple one-piece support trays for the lower run
- To your requirements and specification
- 4 options available

More information ► From page 1356

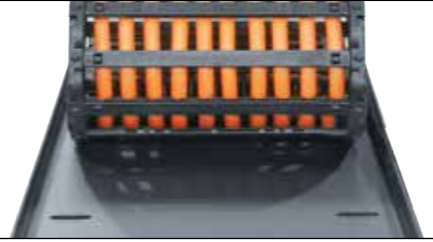
**Hot swarf up to +850°C for e-tubes**

- Lids and shelves can repel swarf up to +850°C. Special production option with the igus® material igumid HT
- No hot swarf melting or embedding into the chain

More information ► www.igus.eu/HT

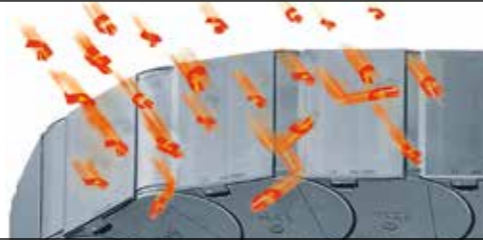
**Reduce assembly time - E4 e-chain® opener**

- e-chain® opener tools for easy opening and closing of e-chains®
- Simple opening and closing of e-chain® crossbars
- Also for use in hard to reach locations
- Significant assembly time reduction

More information ► www.igus.eu/E4savetime

**Roller crossbars - increase the service life of cables and hoses**

- Significantly reduce jacket abrasion of very stiff cables and hoses with rolling contact surfaces equipped with tribo-optimised bearings
- For sensitive hoses in restricted space
- Usable along the inner and/or outer radius, retrofit possible

More information ► upon request

**CFU strain relief with innovative honeycomb design**

- Fast filling, openable from both sides for assembly in seconds
- Flexible honeycomb design for increased holding force
- Tribologically optimised honeycomb design for the best hold
- Universal use, compact, space-saving design

More information ► Page 1422



igus® e-chains® can even withstand the difficult conditions in stone processing facilities. The task of this e-chain® is to supply the tool carriage with energy (up to 100 A), signals, compressed air and water. It can travel up to 12m and achieves speeds of up to 32m/min.

Option: E4Q - the next generation of easy-to-assemble igus® e-chains®

The latest E4Q e-chains® generation combines proven design features of the 12-year old, robust E4.1 e-chains® standard with new bionic design elements and a novel opening mechanism. This gives the E4Q an even longer service life and significantly improved ease of installation.

- Opening and closing completely without tools
- Greater strength and longer unsupported lengths
- Lighter e-chain® links due to material saving
- Optional noise dampening - new system for noise reduction

More information ► From page 580

New

E4.1 | Series E4.56·H4.56·R4.56 | Product range

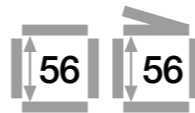

Strong due to undercut design, large inner height



e-chains® | Series E4.56 | Crossbars every link (crossbars removable along the inner and outer radius)
e-chains® | Series H4.56 | Crossbars every 2nd link (crossbars removable along the inner and outer radius)
e-tubes | Series R4.56 | Fully enclosed (lids openable along the outer radius, from one side)

Part No.	Bi	Ba	E4.56	H4.56	R4.56	Part No.	Bi	Ba	E4.56	H4.56	R4.56
e-chains® / e-tubes	[mm]	[mm]	[kg/m]	[kg/m]	[kg/m]	e-chains® / e-tubes	[mm]	[mm]	[kg/m]	[kg/m]	[kg/m]
E4. H4. - 56.05. R.0	50	84	≈ 3.60	≈ 3.59	-	E4. H4. - 56.28. R.0	287	322	≈ 5.32	≈ 4.45	-
E4. H4. - 56.055. R.0	55	89	≈ 3.65	≈ 3.62	-	E4. H4. R4. 56.30. R.0	300	334	≈ 5.48	≈ 4.53	≈ 7.31
E4. H4. - 56.06. R.0	65	99	≈ 3.69	≈ 3.63	-	E4. H4. - 56.31. R.0	312	347	≈ 5.51	≈ 4.54	-
E4. H4. R4. 56.07. R.0	75	109	≈ 3.76	≈ 3.67	≈ 4.31	E4. H4. - 56.32. R.0	325	359	≈ 5.62	≈ 4.60	-
E4. H4. - 56.08. R.0	87	121	≈ 3.85	≈ 3.71	-	E4. H4. - 56.33. R.0	337	372	≈ 5.74	≈ 4.66	-
E4. H4. R4. 56.10. R.0	100	134	≈ 3.93	≈ 3.75	≈ 4.65	E4. H4. R4. 56.35. R.0	350	384	≈ 5.88	≈ 4.73	≈ 8.00
E4. H4. - 56.11. R.0	112	147	≈ 4.05	≈ 3.81	-	E4. H4. - 56.36. R.0	362	397	≈ 5.90	≈ 4.74	-
E4. H4. R4. 56.12. R.0	125	159	≈ 4.13	≈ 3.85	≈ 5.01	E4. H4. - 56.37. R.0	375	409	≈ 6.02	≈ 4.79	-
E4. H4. - 56.13. R.0	137	172	≈ 4.26	≈ 3.92	-	E4. H4. - 56.38. R.0	387	422	≈ 6.06	≈ 4.82	-
E4. H4. R4. 56.15. R.0	150	184	≈ 4.28	≈ 3.93	≈ 5.36	E4. H4. R4. 56.40. R.0	400	434	≈ 6.01	≈ 4.79	≈ 8.68
E4. H4. - 56.16. R.0	162	197	≈ 4.41	≈ 3.99	-	E4. H4. - 56.41. R.0	412	447	≈ 6.25	≈ 4.91	-
E4. H4. - 56.169. R.0	169	204	≈ 4.49	≈ 4.03	-	E4. H4. - 56.42. R.0	425	459	≈ 6.37	≈ 4.97	-
E4. H4. R4. 56.17. R.0	175	209	≈ 4.55	≈ 4.06	≈ 5.73	E4. H4. - 56.43. R.0	437	472	≈ 6.46	≈ 5.01	-
E4. H4. - 56.182. R.0	182	217	≈ 4.59	≈ 4.08	-	E4. H4. - 56.45. R.0	450	484	≈ 6.65	≈ 5.11	-
E4. H4. - 56.18. R.0	187	222	≈ 4.66	≈ 4.12	-	E4. H4. R4. 56.46. R.0	462	497	≈ 6.70	≈ 5.14	≈ 9.52
E4. H4. R4. 56.20. R.0	200	234	≈ 4.71	≈ 4.14	≈ 5.96	E4. H4. - 56.47. R.0	475	509	≈ 6.73	≈ 5.15	-
E4. H4. - 56.207. R.0	207	242	≈ 4.77	≈ 4.17	-	E4. H4. - 56.48. R.0	487	522	≈ 6.80	≈ 5.19	-
E4. H4. - 56.21. R.0	212	247	≈ 4.78	≈ 4.18	-	E4. H4. - 56.50. R.0	500	534	≈ 6.96	≈ 5.26	-
E4. H4. - 56.22. R.0	225	259	≈ 4.85	≈ 4.21	-	E4. H4. - 56.51. R.0	512	547	≈ 7.01	≈ 5.29	-
E4. H4. - 56.23. R.0	237	272	≈ 4.96	≈ 4.27	-	E4. H4. - 56.52. R.0	525	559	≈ 7.14	≈ 5.36	-
E4. H4. R4. 56.25. R.0	250	284	≈ 5.07	≈ 4.32	≈ 6.64	E4. H4. - 56.53. R.0	537	572	≈ 7.23	≈ 5.40	-
E4. H4. - 56.26. R.0	262	297	≈ 5.16	≈ 4.37	-	E4. H4. - 56.55. R.0	550	584	≈ 7.65	≈ 5.61	-
E4. H4. R4. 56.27. R.0	275	309	≈ 5.27	≈ 4.42	≈ 6.97	E4. H4. - 56.60. R.0	600	634	≈ 7.38	≈ 5.48	-

▲ ESD version (Electro Static Discharge) available from stock. More information ▶ From page 142
 1) Lid removable, non-openable *Radius not available for e-tubes

Available bend radii

R [mm] | 135* | 150 | 175 | 200 | 240 | 250 | 300 | 350 | 400 | 450 | 500 |

Complete Part No. with required radius (R). Example:

E4.56.30.300.0 = crossbars every link / H4.56.30.300.0 = crossbars every 2nd link / R4.56.30.300.0 = fully enclosed

ESD - many sizes from stock

- Standardised product made from igumid ESD
 - ESD material tested for over 10 million cycles for the toughest requirements
 - Short delivery times including mounting brackets and interior separation; 24hrs, from stock
- More information and the complete product range ▶ From page 142



E4.1 | E4.56·H4.56·R4.56 | Installation dimensions

Unsupported applications | Short travels

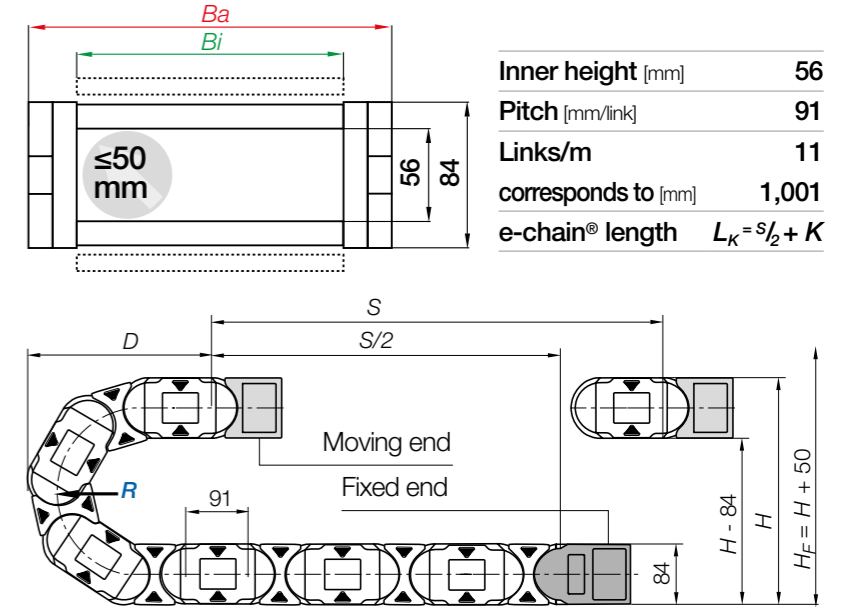
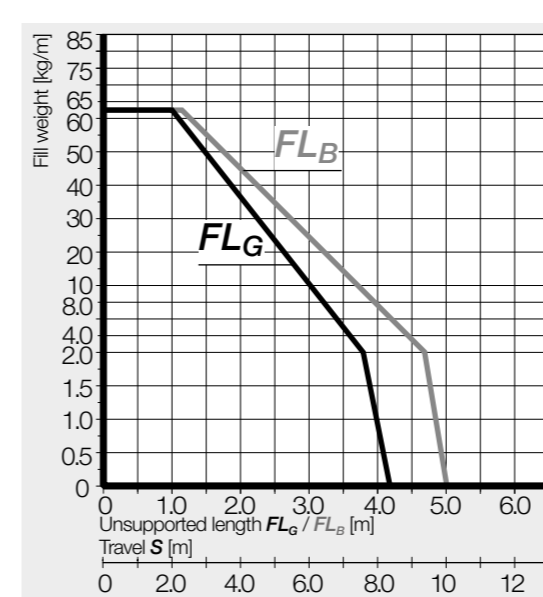

R	135*	150	175	200	240	250	300	350	400	450	500
H ₂₅ ⁰	354	384	434	484	564	584	684	784	884	984	1084
D	314	329	354	379	419	429	479	529	579	629	679
K	610	655	735	815	940	970	1,125	1,285	1,440	1,600	1,755

The required clearance height: $H_F = H + 50\text{mm}$ (with 3.0kg/m fill weight)

*Radius not available for e-tubes

Gliding applications | For travel lengths from 12m to max. 400m

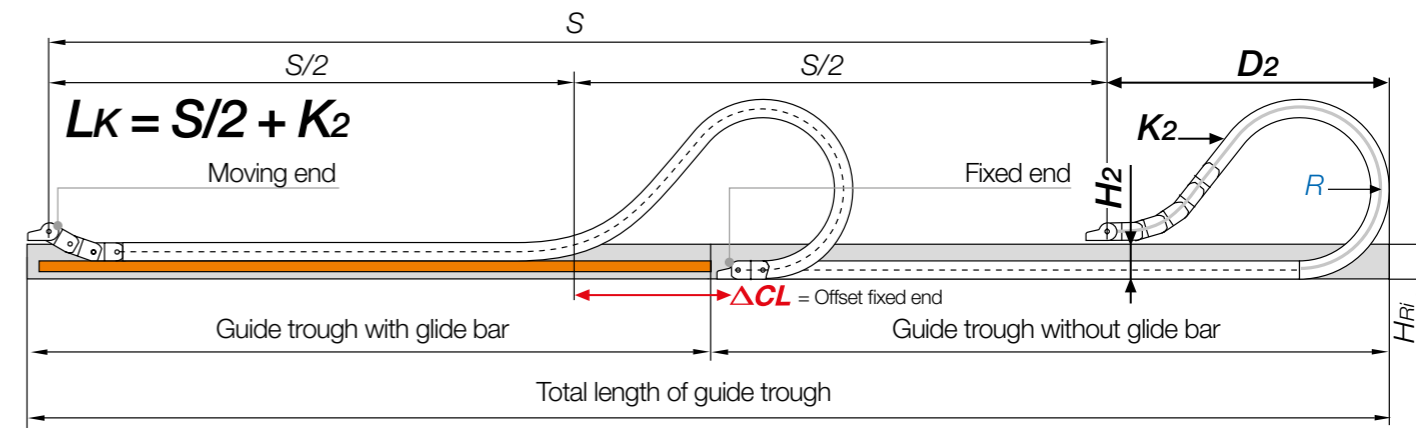

Note: We recommend the project planning of such a system to be carried out by igus®.

In case of travels between 10 and 12m we recommend an e-chain® with a longer unsupported length.

R	135*	150	175	200	240	250	300	350	400	450	500
H ₂	270	266	266	266	266	266	266	266	266	266	266
D ₂₅ ⁺	268	450	580	710	900	980	1,180	1,440	1,530	1,700	1,850
K ₂	610	819	1,092	1,274	1,547	1,638	2,002	2,275	2,548	2,912	3,276
ΔCL	-	159	259	359	509	559	709	909	959	1,059	1,159

*Radius not available for e-tubes

E4.1 | e-chains® E4.56-H4.56 | Accessories

KMA mounting brackets | Attachment from any side | Pivoting | Locking

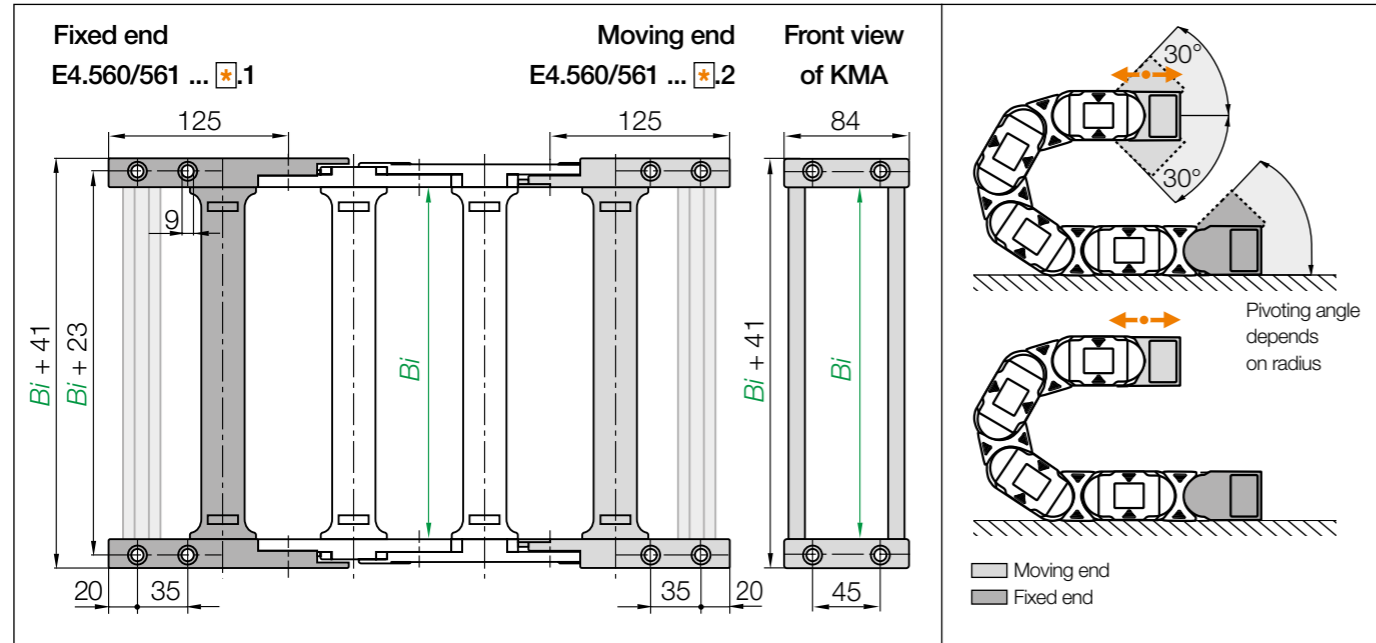

KMA pivoting | Recommended for unsupported and gliding applications
KMA locking | Recommended for vertical hanging and standing applications

Width index	Part No. full set KMA pivoting	Part No. full set KMA locking	Bi [mm]	Width index	Part No. full set KMA pivoting	Part No. full set KMA locking	Bi [mm]
05.	E4.560.05	E4.561.05	50	28.	E4.560.28	E4.561.28	287
055.	E4.560.055	E4.561.055	55	30.	E4.560.30	E4.561.30	300
06.	E4.560.06	E4.561.06	65	31.	E4.560.31	E4.561.31	312
07.	E4.560.07	E4.561.07	75	32.	E4.560.32	E4.561.32	325
08.	E4.560.08	E4.561.08	87	33.	E4.560.33	E4.561.33	337
10.	E4.560.10	E4.561.10	100	35.	E4.560.35	E4.561.35	350
11.	E4.560.11	E4.561.11	112	36.	E4.560.36	E4.561.36	362
12.	E4.560.12	E4.561.12	125	37.	E4.560.37	E4.561.37	375
13.	E4.560.13	E4.561.13	137	38.	E4.560.38	E4.561.38	387
15.	E4.560.15	E4.561.15	150	40.	E4.560.40	E4.561.40	400
16.	E4.560.16	E4.561.16	162	41.	E4.560.41	E4.561.41	412
169.	E4.560.169	E4.561.169	169	42.	E4.560.42	E4.561.42	425
17.	E4.560.17	E4.561.17	175	43.	E4.560.43	E4.561.43	437
182.	E4.560.182	E4.561.182	182	45.	E4.560.45	E4.561.45	450
18.	E4.560.18	E4.561.18	187	46.	E4.560.46	E4.561.46	462
20.	E4.560.20	E4.561.20	200	47.	E4.560.47	E4.561.47	475
207.	E4.560.207	E4.561.207	207	48.	E4.560.48	E4.561.48	487
21.	E4.560.21	E4.561.21	212	50.	E4.560.50	E4.561.50	500
22.	E4.560.22	E4.561.22	225	51.	E4.560.51	E4.561.51	512
23.	E4.560.23	E4.561.23	237	52.	E4.560.52	E4.561.52	525
25.	E4.560.25	E4.561.25	250	53.	E4.560.53	E4.561.53	537
26.	E4.560.26	E4.561.26	262	55.	E4.560.55	E4.561.55	550
27.	E4.560.27	E4.561.27	275	60.	E4.560.60	E4.561.60	600

(KMA = polymer metal mounting bracket) For the C-profile option please add index .C

E4.1 | e-tubes R4.56 | Accessories

KMA mounting brackets | Attachment from any side | Pivoting | Locking

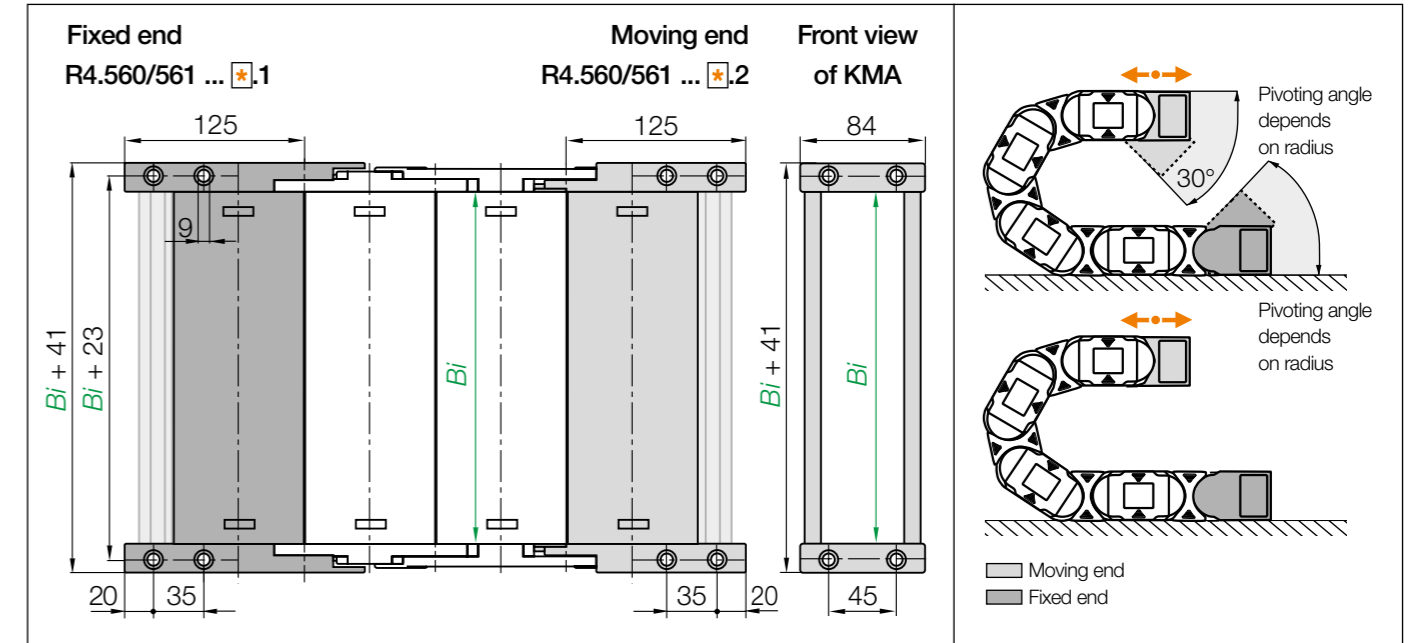

KMA pivoting | Recommended for unsupported and gliding applications
KMA locking | Recommended for vertical hanging and standing applications

Width index	Part No. full set KMA pivoting	Part No. full set KMA locking	Bi [mm]	Width index	Part No. full set KMA pivoting	Part No. full set KMA locking	Bi [mm]
07.	R4.560.07	R4.561.07	75	25.	R4.560.25	R4.561.25	250
10.	R4.560.10	R4.561.10	100	27.	R4.560.27	R4.561.27	275
12.	R4.560.12	R4.561.12	112	30.	R4.560.30	R4.561.30	300
15.	R4.560.15	R4.561.15	150	35.	R4.560.35	R4.561.35	350
17.	R4.560.17	R4.561.17	175	40.	R4.560.40	R4.561.40	400
20.	R4.560.20	R4.561.20	200	46.	R4.560.46	R4.561.46	462

(KMA = polymer metal mounting bracket) For the C-profile option please add index .C

Note: The e-chains® may end with either an inner or an outer side link. An outer side link should always be the first e-chain® link at the moving end. Please specify the index 1 (for odd) or 2 (for even) depending on an even or odd number of links required.

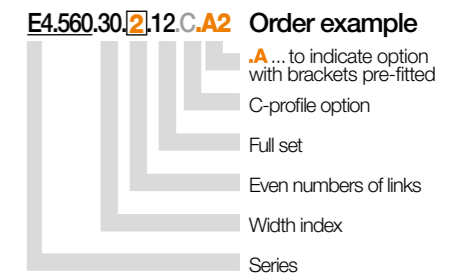
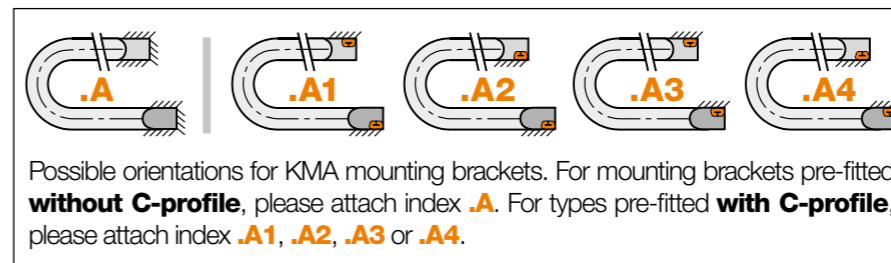
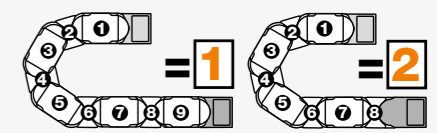

Strain relief e.g. clamps, tie-wrap plates, nuggets and clips are available from stock. The complete chainfix range with ordering options ▶ From page 1392

Previous generation of interior separation with other options ► www.igus.eu/E4.56

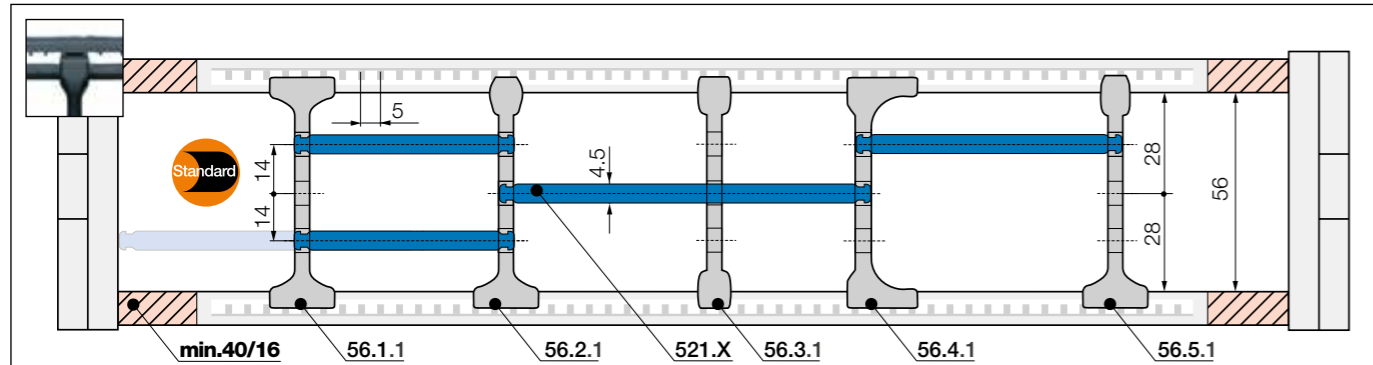

Note: Please be aware of the minimum lateral gap to the side links! **e-tube: 40mm** | **e-chain®: 16mm**
As standard separators are fitted every 2nd e-chain® link!

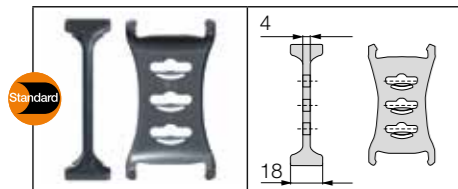

Standard separator, wide base
unassembled **56.1**
assembled **56.1.1**

Standard - for any application
Separator with a wide base for maximum holding force.

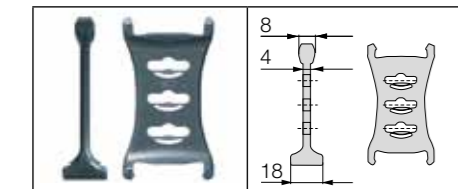

Separator, narrow top
unassembled **56.2**
assembled **56.2.1**

For even faster installation
Wide on one side for high holding force, narrow on opposite side for easy cable fitting.

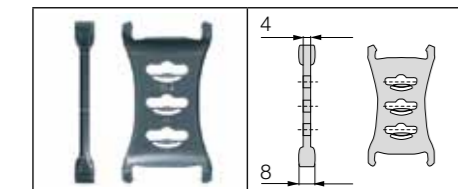

Separator, narrow
unassembled **56.3**
assembled **56.3.1**

For small cables
Separator with a narrow base for a large number of small cables side by side. Saves space.

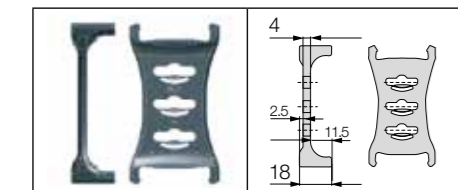

Separator, asymmetrical
unassembled **56.4**
assembled **56.4.1**

For side-mounted applications
Asymmetrical separator, for defined gap distance. No additional spacers required.

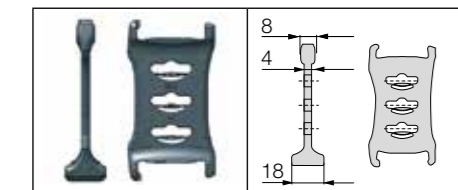

Notch separator for notched crossbar
unassembled **56.5**
assembled **56.5.1**

Locks securely in preset increments
Notch separator for exact positioning. Recommended for side-mounted applications.

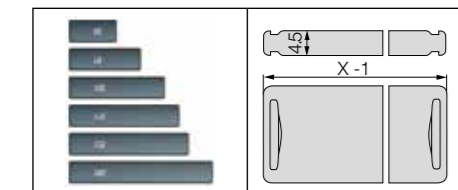

Shelf, lockable
unassembled **520.X**
assembled **521.X**

Horizontal separation
Full-width shelf locks securely into separators at both ends, giving a fixed width. Can be used as full-width or partial shelf.

Shelves Width = X [mm]	X [mm]		X [mm]		X [mm]		X [mm]	
	unassembled	assembled	unassembled	assembled	unassembled	assembled	unassembled	assembled
	050	520.050	150	520.150	300	520.300	450	520.450
	065	520.065	175	520.175	350	520.350	475	520.475
	075	520.075	200	520.200	375	520.375	487	520.387
	100	520.100	225	520.225	387	520.387	512	520.512
	125	520.125	250	520.250	450	520.450	525	521.525

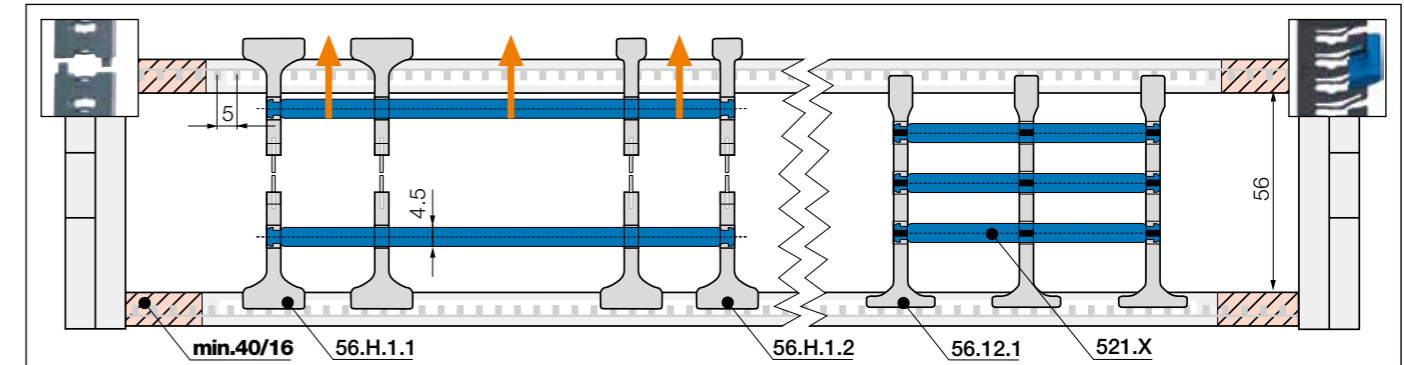

Note: Please be aware of the minimum lateral gap to the side links! **e-tube: 40mm** | **e-chain®: 16mm**
As standard separators are fitted every 2nd e-chain® link!

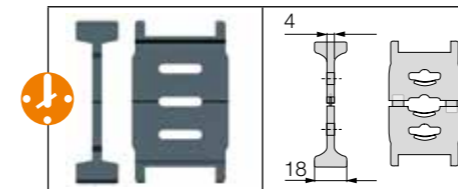

Split separator, wide base/top
unassembled **56.H.1**
assembled **56.H.1.1**

Split separators
In order to fill e-chains® more easily and effectively, these separators can be split in the middle. This allows easier access to middle shelf partitions. Fast assembly and easy retrofit. 2 types available: with wide or narrow top.

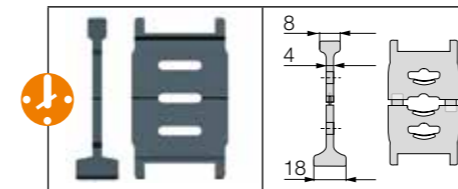

Split separator, narrow top
unassembled **56.H.2**
assembled **56.H.2.1**

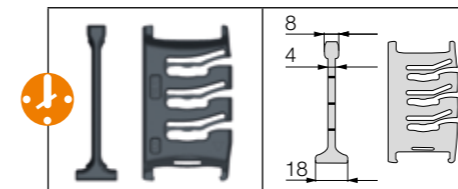

Lean separator¹⁾
unassembled **56.12**
assembled **56.12.1**

Lean separators¹⁾
For quick fitting of shelves in several layers.
1) Note: Please combine maximum 4 lean separators with one shelf. Not suitable for side-mounted e-chains®!

With the lean separator you can quickly insert several layers of cables into the e-chain® and reduce the installation time by up to 50%²⁾.

2) Lean interior separation vs. Standard separator - measured on a 4m long e-chain® fitted with 12 cables in the igus® readychain® factory



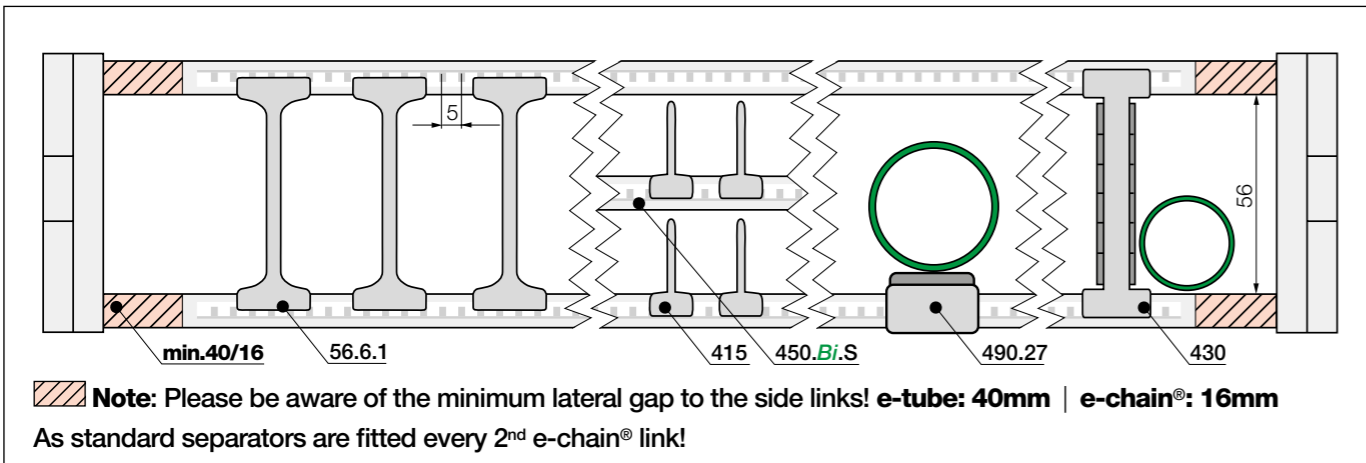

		Notch locking separator*, lockable for e-chains® unassembled 56.6 assembled 56.6.1
--	--	---

Notch locking separator* for increased holding force
 Notch locking separators offer higher crossbar opening forces for high humidity and/or large hydraulic hoses. They can be positioned precisely and then locked in position.

		Partial height separator*, for e-chains® unassembled 405 assembled 415
--	--	---

Partial height separator*
 In conjunction with an additional opening crossbar, **part no. 450.Bi.S**, it provides the option to separate the upper and lower halves of the e-chain® independently of each other.

		Rollclip*, for e-chains® unassembled 489.27 assembled 490.27
--	--	---

Rollclip*
 Minimises abrasion of sensitive hoses. Simply clamps onto the opening crossbar. The movable rollers compensate for relative movement between the e-chain® and hose.

		Roller separator*, for e-chains® unassembled 429 assembled 430
--	--	---

Roller separator*
 The roller separator is used in a similar way to the rollclip. It is used like a separator. For rigid cables and hoses.
 *Only suitable for e-chains®

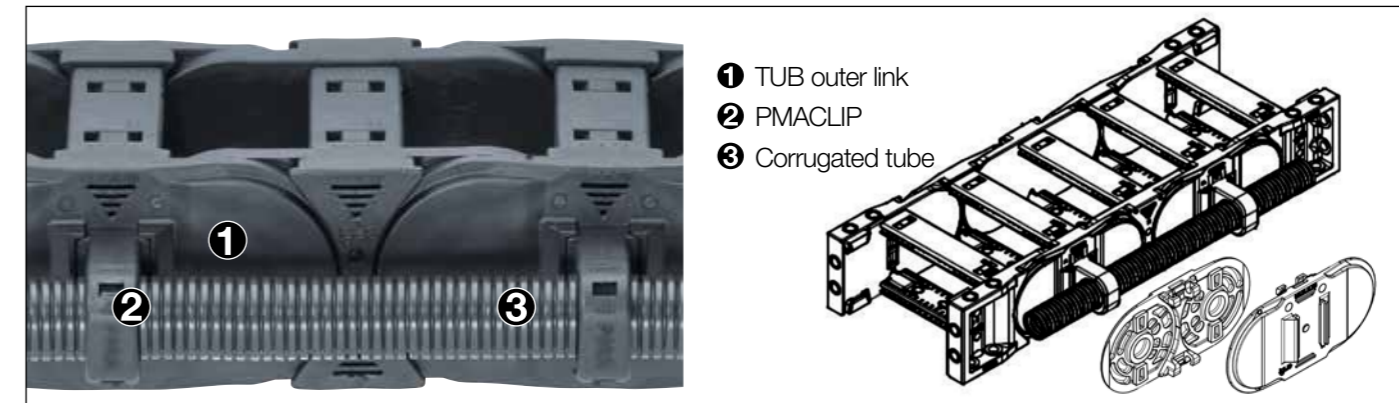

TUB | Safe guidance for corrugated tubes parallel to the e-chain®

- Additional, simple guidance for corrugated tubes on the outside of the e-chain®
- PMACLIP support to be easily clipped on corrugated tubes with nominal widths 17, 23, 29, 36, 48mm
- Easy access to the corrugated tubes, fast replacement of the hoses
- Reduce assembly time and cost - easy to assemble, without any additional screws or tools
- The part number includes the e-chain® with TUB side sections; the PMACLIP support and the hose are ordered separately

Part No. TUB	Part No. TUB	Part No. TUB	For corrugated tube nominal diameter
Outer link right*	Outer link left*	Outer link at both ends*	Ø [mm]
E4.56.XXXTUBR.R.0	E4.56.XXXTUBL.R.0	E4.56.XXXTUB.R.0	17 / 23 / 29 / 36 / 48

*As viewed from the fixed end

Complete Part No. with the width index **XXX** of **Bi** and the minimum bend radius (**R**). Example:

E4.56.10TUBR.150.0 = with TUB outer sections every 2nd right hand link

Product range | PMACLIP | Support, one-piece, with safety clip

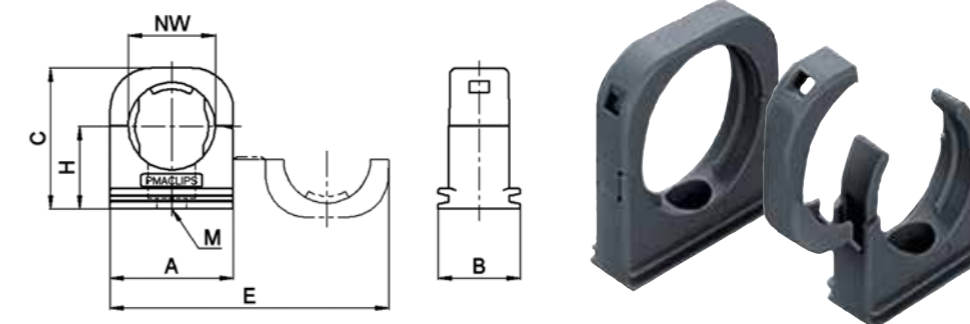

PMACLIP support - one-piece construction with safety clip, suitable for corrugated tubes

Part No.	NW	A	B	C	H	E	M
PMACLIP	Ø [mm]	mm	mm	mm	mm	mm	mm
I-BFH-17-0	17	30.0	20.0	34.0	20.0	68.0	M6
I-BFH-23-0	23	38.5	20.0	42.0	24.0	85.0	M6
I-BFH-29-0	29	45.5	20.0	48.0	27.0	99.0	M6
I-BFH-36-0	36	55.5	20.0	56.0	31.0	119.0	M6
I-BFH-48-0	48	67.5	20.0	68.0	37.0	143.0	M6

Extender crossbar with fixed width

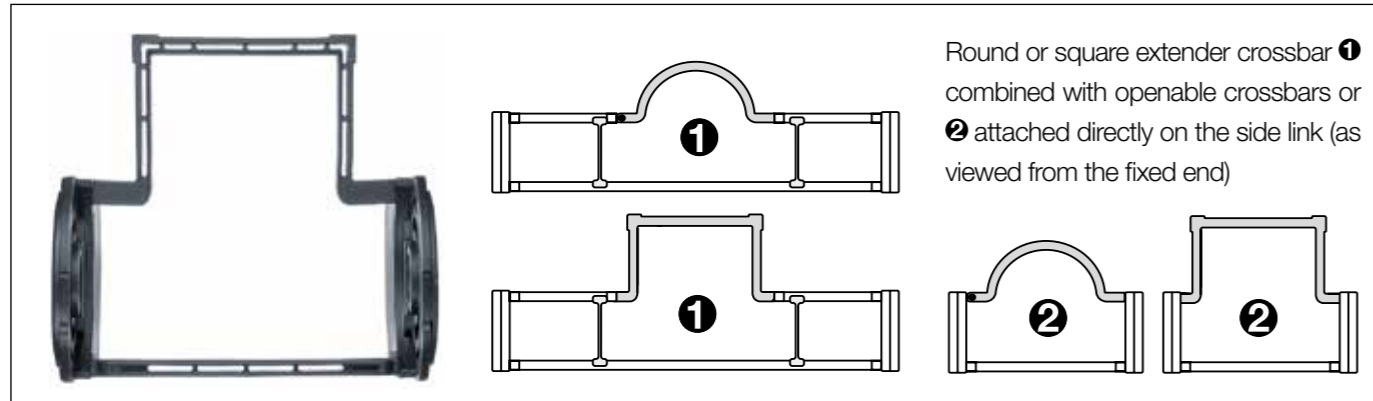

Extender crossbars with fixed width | Safe guiding for large hoses

- Suitable for hoses with a maximum outer diameter of 245mm
- Option 1 extender crossbars with fixed width to combine with openable crossbars
- Option 2 extender crossbars with fixed width attached directly on the side link
- Optionally openable along the inner "Z" or the outer radius "E"
- Gliding with crossbars assembled along the outer radius and a special guide trough

Part No. extender crossbar with fixed width, as individual parts	Hose $\varnothing \leq$ [mm]	Extender crossbar shape	2 Fitted to side link	1 Combine with openable crossbars
450.15RHD115	115	○ round	No	Yes
450.17RD115	115	○ round	Yes	No
450.25D150	150	□ square	Yes	No
450.30D200	180	□ square	Yes	No
450.35D250	195	□ square	Yes	No
450.40D300	245	□ square	Yes	No
450.20HD150	150	□ square	No	Yes
450.25HD200	180	□ square	No	Yes
450.30HD250	195	□ square	No	Yes

Order example: 1 combined with openable crossbars

To receive extender crossbar RHD115 pre-fitted along the outer radius of the-chain®, please add index **E**: E4.56.10/15RHDE115/10.R.0

To receive extender crossbar RHD115 pre-fitted along the inner radius of the-chain®, please add index **Z**: E4.56.10/15RHDZ115/10.R.0

Order example: 2 fitted to side link

To receive extender crossbar RD115 pre-fitted along the outer radius of the-chain®, please add index **E**: E4.56.17RDE115.R.0

To receive extender crossbar RD115 pre-fitted along the inner radius of the-chain®, please add index **Z**: E4.56.17RDZ115.R.0

Extension links

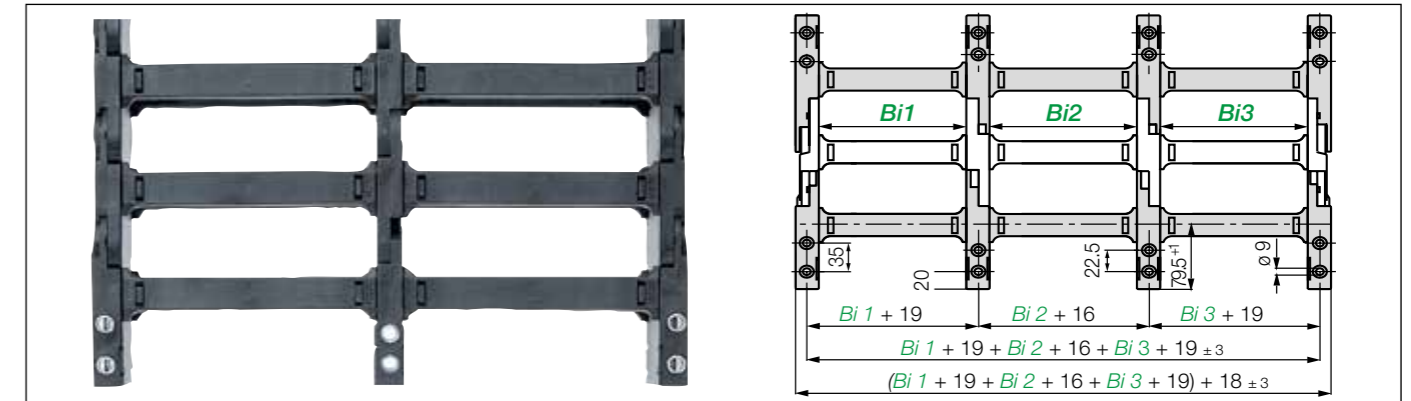

Extension links | For extremely wide e-chains® up to 3.0m

- Virtually unlimited side-by-side extension
- For extremely wide e-chains® up to 3000mm
- Unsupported length FL_G max. can be increased when heavy fill weights are required
- e-chains® and e-tubes can be combined
- Attached with KMA or steel mounting brackets

Part No. Extension link e-chain®	Part No. Extension link e-tube	Part No. Extension link as an individual part
E4.56.Bi1/Bi2/Bi3.R.0	R4.56.Bi1/Bi2/Bi3.R.0	422.R.

Complete Part No. with the width index **Bi1/Bi2/Bi3/etc.** and the radius (**R**). Example: E4.56.10/20/10.200.0



With the E4.1 TUB, corrugated tubes can be reliably guided in parallel, saving space

Steel support tray for support of the lower run

- Simple one-piece support trays for the lower run
 - To your requirements and specification
 - 4 options available
- More information ► From page 1356



Hot swarf up to +850°C for e-tubes

- Lids and shelves can repel swarf up to +850°C. Special production option with the igus® material igumid HT
 - No hot swarf melting or embedding into the chain
- More information ► www.igus.eu/HT



Reduce assembly time - E4 e-chain® opener

- e-chain® opener tools for easy opening and closing of e-chains®
 - Simple opening and closing of e-chain® crossbars
 - Also for use in hard to reach locations
 - Significant assembly time reduction
- More information ► www.igus.eu/E4savetime



Roller crossbars - increase the service life of cables and hoses

- Significantly reduce jacket abrasion of very stiff cables and hoses with rolling contact surfaces equipped with tribo-optimised bearings
 - For sensitive hoses in restricted space
 - Usable along the inner and/or outer radius, retrofit possible
- More information ► upon request



Also available for heavy-duty applications | Series 4040HD·R8840HD

Heavy-duty version - for very long travels or heavy fill weights

- High torsional rigidity and tensile strength
- Tough steel mounting brackets
- For long-term operation in very humid environments

Series 4040HD·R8840HD - more information ► www.igus.eu/4040HD



E4.1 as a noise-optimised version with extension links. Unsupported application with high fill weight. Harnessed with rigid hydraulic hoses. The max. noise level can be reduced up to 9dB(A) using the optional rubber dampers

Option: E4Q - the next generation of easy-to-assemble igus® e-chains®

The latest E4Q e-chains® generation combines proven design features of the 12-year old, robust E4.1 e-chains® standard with new bionic design elements and a novel opening mechanism. This gives the E4Q an even longer service life and significantly improved ease of installation.

- Opening and closing completely without tools
- Greater strength and longer unsupported lengths
- Lighter e-chain® links due to material saving
- Optional noise dampening - new system for noise reduction

More information ► From page 580

New



E4.1 | Series E4.80·H4.80·R4.80 | Product range

Strong due to undercut design, new very large inner height

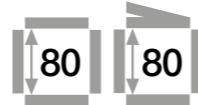

e-chains® | Series E4.80 | Crossbars every link (crossbars removable along the inner and outer radius)
e-chains® | Series H4.80 | Crossbars every 2nd link (crossbars removable along the inner and outer radius)
e-tubes | Series R4.80 | Fully enclosed (lids openable along the outer radius, from one side)

Part No.	Bi	Ba	E4.80	H4.80	R4.80	Part No.	Bi	Ba	E4.80	H4.80	R4.80
e-chains® / e-tubes	[mm]	[mm]	[kg/m]	[kg/m]	[kg/m]	e-chains® / e-tubes	[mm]	[mm]	[kg/m]	[kg/m]	[kg/m]
E4. H4. - 80.05. R.0	50	100	≈ 5.73	≈ 5.72	-	E4. H4. - 80.28. R.0	287	338	≈ 7.14	≈ 6.42	-
E4. H4. - 80.055. R.0	55	105	≈ 5.77	≈ 5.74	-	E4. H4. R4. 80.30. R.0	300	350	≈ 7.27	≈ 6.49	≈ 9.22
E4. H4. - 80.06. R.0	65	115	≈ 5.80	≈ 5.76	-	E4. H4. - 80.31. R.0	312	363	≈ 7.30	≈ 6.50	-
E4. H4. - 80.07. R.0	75	125	≈ 5.86	≈ 5.78	-	E4. H4. - 80.32. R.0	325	375	≈ 7.38	≈ 6.54	-
E4. H4. - 80.08. R.0	87	137	≈ 5.93	≈ 5.82	-	E4. H4. - 80.33. R.0	337	388	≈ 7.48	≈ 6.59	-
E4. H4. R4. 80.10. R.0	100	150	≈ 6.00	≈ 5.85	≈ 6.70	E4. H4. R4. 80.35. R.0	350	400	≈ 7.59	≈ 6.65	≈ 9.90
E4. H4. - 80.11. R.0	112	163	≈ 6.10	≈ 5.90	-	E4. H4. - 80.36. R.0	362	413	≈ 7.61	≈ 6.66	-
E4. H4. - 80.12. R.0	125	175	≈ 6.16	≈ 5.93	-	E4. H4. - 80.37. R.0	375	425	≈ 7.71	≈ 6.71	-
E4. H4. - 80.13. R.0	137	188	≈ 6.27	≈ 5.99	-	E4. H4. - 80.38. R.0	387	438	≈ 7.74	≈ 6.73	-
E4. H4. R4. 80.15. R.0	150	200	≈ 6.30	≈ 6.01	≈ 7.34	E4. H4. R4. 80.40. R.0	400	450	≈ 7.84	≈ 6.77	≈ 10.52
E4. H4. - 80.16. R.0	162	213	≈ 6.39	≈ 6.05	-	E4. H4. - 80.41. R.0	412	463	≈ 7.90	≈ 6.80	-
E4. H4. - 80.169. R.0	169	220	≈ 6.46	≈ 6.08	-	E4. H4. - 80.42. R.0	425	475	≈ 8.00	≈ 6.85	-
E4. H4. - 80.17. R.0	175	225	≈ 6.50	≈ 6.11	-	E4. H4. - 80.43. R.0	437	488	≈ 8.07	≈ 6.89	-
E4. H4. - 80.182. R.0	182	233	≈ 6.54	≈ 6.12	-	E4. H4. - 80.45. R.0	450	500	≈ 8.23	≈ 6.97	-
E4. H4. - 80.18. R.0	187	238	≈ 6.59	≈ 6.15	-	E4. H4. R4. 80.46. R.0	462	513	≈ 8.26	≈ 6.99	≈ 11.33
E4. H4. R4. 80.20. R.0	200	250	≈ 6.64	≈ 6.17	≈ 8.09	E4. H4. - 80.47. R.0	475	525	≈ 8.29	≈ 7.00	-
E4. H4. - 80.207. R.0	207	258	≈ 6.68	≈ 6.20	-	E4. H4. - 80.48. R.0	487	538	≈ 8.35	≈ 7.03	-
E4. H4. - 80.21. R.0	212	263	≈ 6.70	≈ 6.20	-	E4. H4. - 80.50. R.0	500	550	≈ 8.48	≈ 7.09	-
E4. H4. - 80.22. R.0	225	275	≈ 6.76	≈ 6.23	-	E4. H4. - 80.51. R.0	512	563	≈ 8.52	≈ 7.11	-
E4. H4. - 80.23. R.0	237	288	≈ 6.84	≈ 6.28	-	E4. H4. - 80.52. R.0	525	575	≈ 8.63	≈ 7.17	-
E4. H4. R4. 80.25. R.0	250	300	≈ 6.94	≈ 6.32	≈ 8.47	E4. H4. - 80.53. R.0	537	588	≈ 8.70	≈ 7.21	-
E4. H4. - 80.26. R.0	262	313	≈ 7.01	≈ 6.36	-	E4. H4. - 80.55. R.0	550	600	≈ 9.05	≈ 7.38	-
E4. H4. - 80.27. R.0	275	325	≈ 7.09	≈ 6.40	-	E4. H4. - 80.60. R.0	600	650	≈ 9.23	≈ 7.47	-

▲ ESD version (Electro Static Discharge) available from stock. More information ▶ From page 142

*Radius not available for e-tubes

Available bend radii

R [mm] | 150* | 200 | 250 | 300 | 350 | 400 | 500 | 550 | 600 | 1,000 |

Complete Part No. with required radius (R). Example:

E4.80.30.300.0 = crossbars every link / H4.80.30.300.0 = crossbars every 2nd link / R4.80.30.300.0 = fully enclosed

ESD - many sizes from stock

- Standardised product made from igumid ESD
 - ESD material tested for over 10 million cycles for the toughest requirements
 - Short delivery times including mounting brackets and interior separation; 24hrs, from stock
- More information and the complete product range ▶ From page 142



E4.1 | E4.80·H4.80·R4.80 | Installation dimensions

Unsupported applications | Short travels

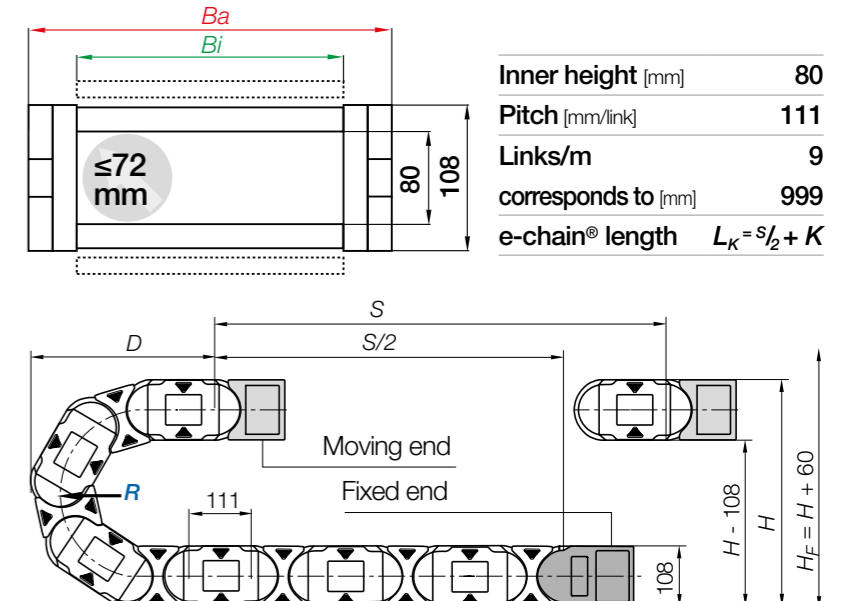
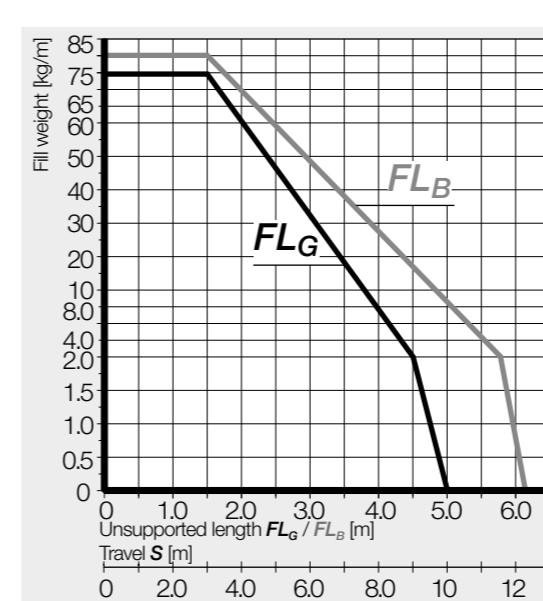

R	150*	200	250	300	350	400	500	550	600	1,000
H _{±25}	408	508	608	708	808	908	1,108	1,208	1,308	2,108
D	371	421	471	521	571	621	721	771	821	1,221
K	695	855	1,010	1,165	1,325	1,480	1,795	1,950	2,110	3,365

The required clearance height: $H_F = H + 60\text{mm}$ (with 3.0kg/m fill weight)

*Radius not available for e-tubes

Gliding applications | For travel lengths from 12m to max. 400m

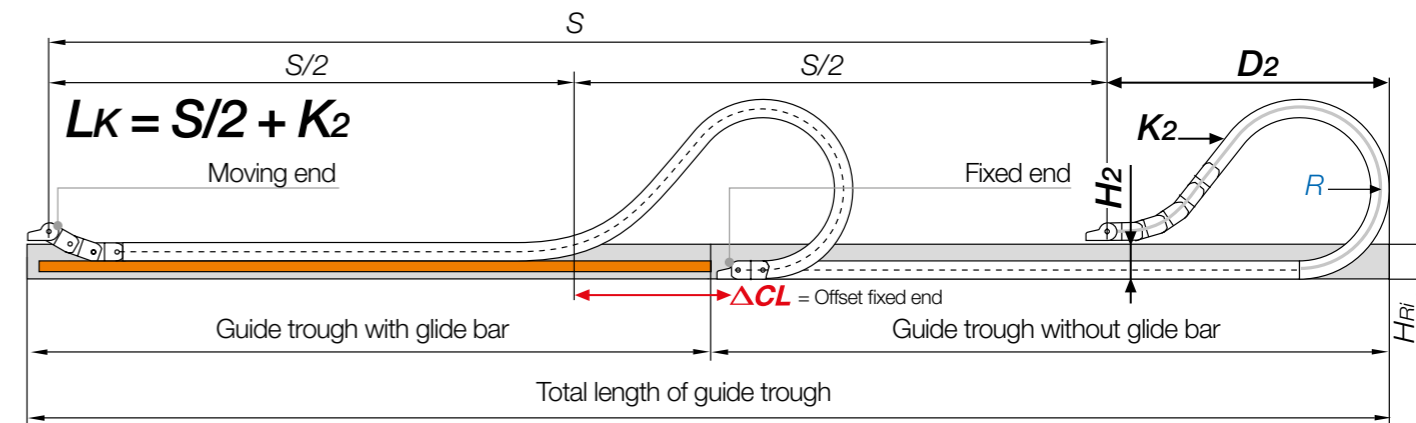

Note: We recommend the project planning of such a system to be carried out by igus®.

In case of travels between 10 and 12m we recommend an e-chain® with a longer unsupported length.

R	150*	200	250	300	350	400	500	550	600	1,000
H ₂	242	242	242	242	242	242	242	-	-	-
D _{2±25}	550	800	1,000	1,200	1,450	1,600	2,100	-	-	-
K ₂	890	1,330	1,665	2,000	2,330	2,660	3,440	-	-	-
ΔCL	189	389	539	689	889	989	1,389	-	-	-

*Radius not available for e-tubes

E4.1 | e-chains® E4.80·H4.80 | Accessories

KMA mounting brackets | Attachment from any side | Pivoting | Locking

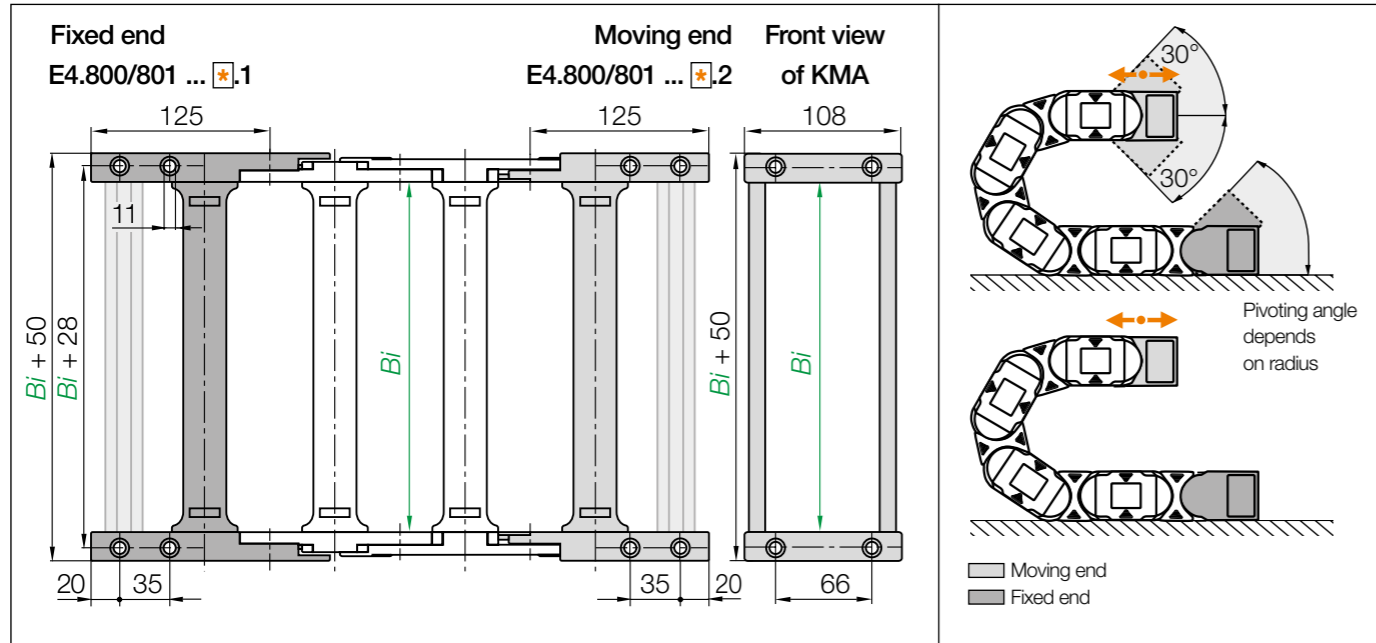

KMA pivoting | Recommended for unsupported and gliding applications
KMA locking | Recommended for vertical hanging and standing applications

Width index	Part No. full set KMA pivoting	Part No. full set KMA locking	Bi [mm]	Width index	Part No. full set KMA pivoting	Part No. full set KMA locking	Bi [mm]
05.	E4.800.05	E4.801.05	50	28.	E4.800.28	E4.801.28	287
055.	E4.800.055	E4.801.055	55	30.	E4.800.30	E4.801.30	300
06.	E4.800.06	E4.801.06	65	31.	E4.800.31	E4.801.31	312
07.	E4.800.07	E4.801.07	75	32.	E4.800.32	E4.801.32	325
08.	E4.800.08	E4.801.08	87	33.	E4.800.33	E4.801.33	337
10.	E4.800.10	E4.801.10	100	35.	E4.800.35	E4.801.35	350
11.	E4.800.11	E4.801.11	112	36.	E4.800.36	E4.801.36	362
12.	E4.800.12	E4.801.12	125	37.	E4.800.37	E4.801.37	375
13.	E4.800.13	E4.801.13	137	38.	E4.800.38	E4.801.38	387
15.	E4.800.15	E4.801.15	150	40.	E4.800.40	E4.801.40	400
16.	E4.800.16	E4.801.16	162	41.	E4.800.41	E4.801.41	412
169.	E4.800.169	E4.801.169	169	42.	E4.800.42	E4.801.42	425
17.	E4.800.17	E4.801.17	175	43.	E4.800.43	E4.801.43	437
182.	E4.800.182	E4.801.182	182	45.	E4.800.45	E4.801.45	450
18.	E4.800.18	E4.801.18	187	46.	E4.800.46	E4.801.46	462
20.	E4.800.20	E4.801.20	200	47.	E4.800.47	E4.801.47	475
207.	E4.800.207	E4.801.207	207	48.	E4.800.48	E4.801.48	487
21.	E4.800.21	E4.801.21	212	50.	E4.800.50	E4.801.50	500
22.	E4.800.22	E4.801.22	225	51.	E4.800.51	E4.801.51	512
23.	E4.800.23	E4.801.23	237	52.	E4.800.52	E4.801.52	525
25.	E4.800.25	E4.801.25	250	53.	E4.800.53	E4.801.53	537
26.	E4.800.26	E4.801.26	262	55.	E4.800.55	E4.801.55	550
27.	E4.800.27	E4.801.27	275	60.	E4.800.60	E4.801.60	600

(KMA = polymer metal mounting bracket) For the C-profile option please add index .C

E4.1 | e-tubes R4.80 | Accessories

KMA mounting brackets | Attachment from any side | Pivoting | Locking

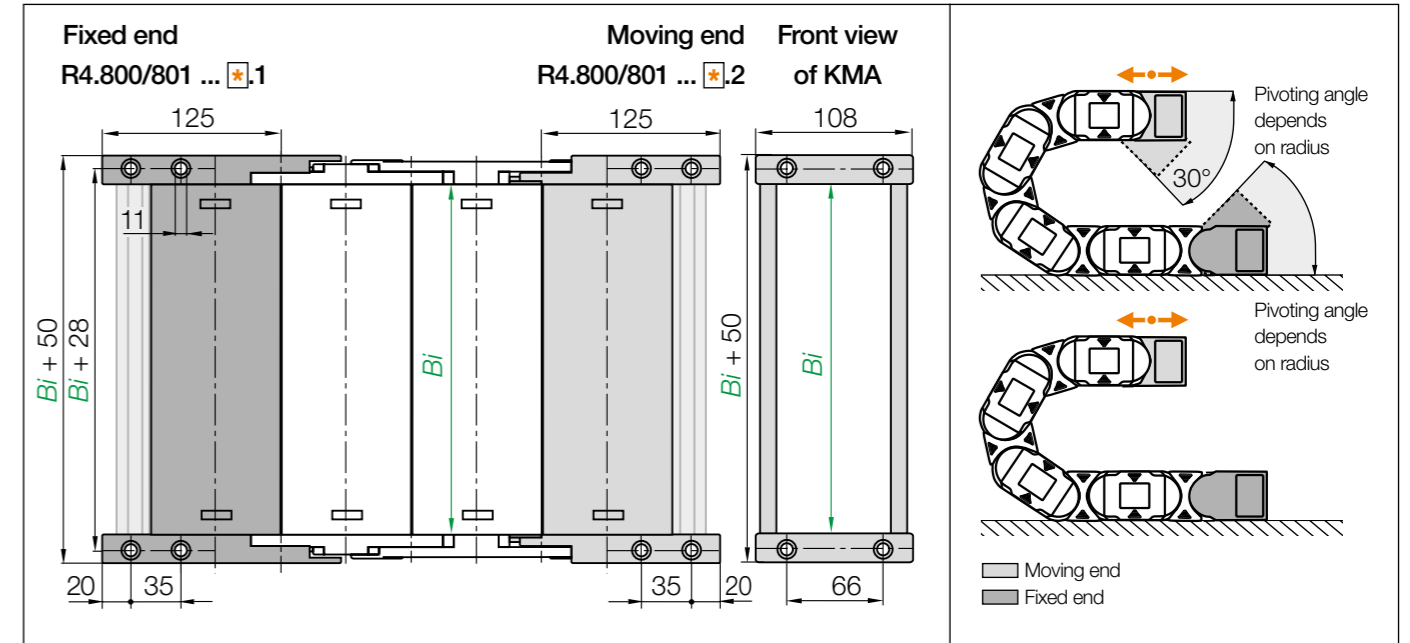

KMA pivoting | Recommended for unsupported and gliding applications
KMA locking | Recommended for vertical hanging and standing applications

Width index	Part No. full set KMA pivoting	Part No. full set KMA locking	Bi [mm]	Width index	Part No. full set KMA pivoting	Part No. full set KMA locking	Bi [mm]
10.	R4.800.10	R4.801.10	100	30.	R4.800.30	R4.801.30	300
15.	R4.800.15	R4.801.15	150	35.	R4.800.35	R4.801.35	350
20.	R4.800.20	R4.801.20	200	40.	R4.800.40	R4.801.40	400
25.	R4.800.25	R4.801.25	250	46.	R4.800.46	R4.801.46	462

(KMA = polymer metal mounting bracket) For the C-profile option please add index .C

Note: The e-chains® may end with either an inner or an outer side link. An outer side link should always be the first e-chain® link at the moving end. Please specify the index 1 (for odd) or 2 (for even) depending on an even or odd number of links required.

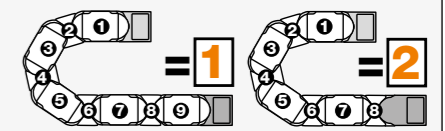

Possible orientations for KMA mounting brackets. For mounting brackets pre-fitted **without C-profile**, please attach index **.A**. For types pre-fitted **with C-profile**, please attach index **.A1, .A2, .A3 or .A4**.

E4.800.30.2.12.C.A2 Order example
.A... to indicate option with brackets pre-fitted
C-profile option
Full set
Even numbers of links
Width index
Series

Strain relief e.g. clamps, tie-wrap plates, nuggets and clips are available from stock. The complete chainfix range with ordering options ▶ From page 1392

E4.1 | Series E4.80·H4.80·R4.80 | Accessories

Interior separation | Increase cable service life

Previous generation of interior separation with other options ► www.igus.eu/E4.80

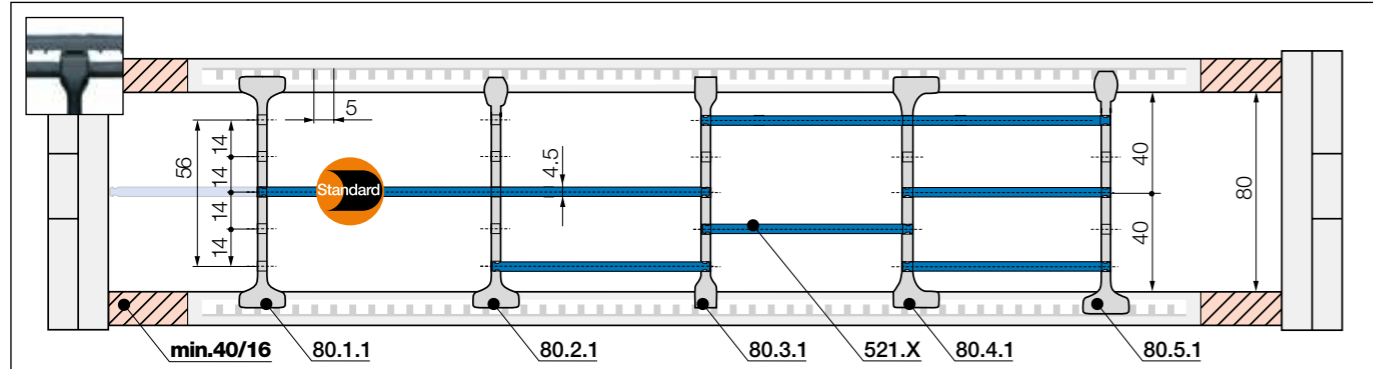

Note: Please be aware of the minimum lateral gap to the side links! **e-tube: 40mm | e-chain®: 16mm**
As standard separators are fitted every 2nd e-chain® link!

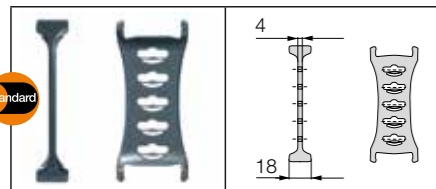

Standard separator, wide base
unassembled **80.1**
assembled **80.1.1**

Standard - for any application
Separator with a wide base for maximum holding force.

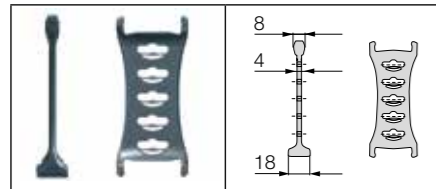

Separator, narrow top
unassembled **80.2**
assembled **80.2.1**

For even faster installation
Wide on one side for high holding force, narrow on opposite side for easy cable fitting.

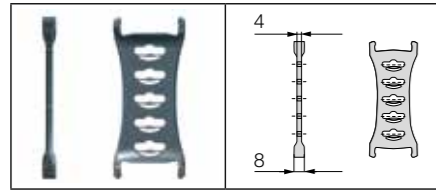

Separator, narrow
unassembled **80.3**
assembled **80.3.1**

For small cables
Separator with a narrow base for a large number of small cables side by side. Saves space.

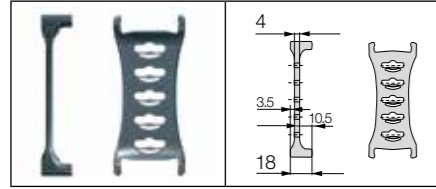

Separator, asymmetrical
unassembled **80.4**
assembled **80.4.1**

For side-mounted applications
Asymmetrical separator, for defined gap distance. No additional spacers required.

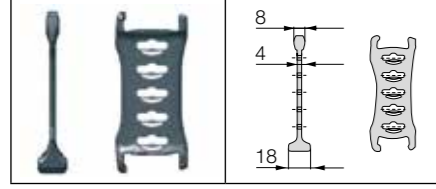

Notch separator for notched crossbar
unassembled **80.5**
assembled **80.5.1**

Locks securely in preset increments
Notch separator for exact positioning. Recommended for side-mounted applications.

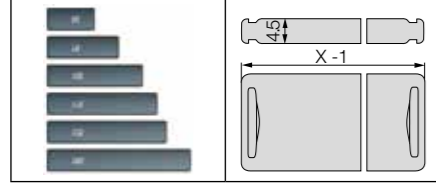

Shelf, lockable
unassembled **520.X**
assembled **521.X**

Horizontal separation
Full-width shelf locks securely into separators at both ends, giving a fixed width. Can be used as full-width or partial shelf.

Shelves Width = X [mm]	X [mm]		X [mm]		X [mm]		X [mm]	
	unassembled	assembled	unassembled	assembled	unassembled	assembled	unassembled	assembled
	050	520.050	150	520.150	300	520.300	450	520.450
	065	520.065	175	520.175	350	520.350		
	075	520.075	200	520.200	375	520.375		
	100	520.100	225	520.225	387	520.387		
	125	520.125	250	520.250	450	520.450		



E4.1 | Series E4.80·H4.80·R4.80 | Accessories

Interior separation | To allow faster filling

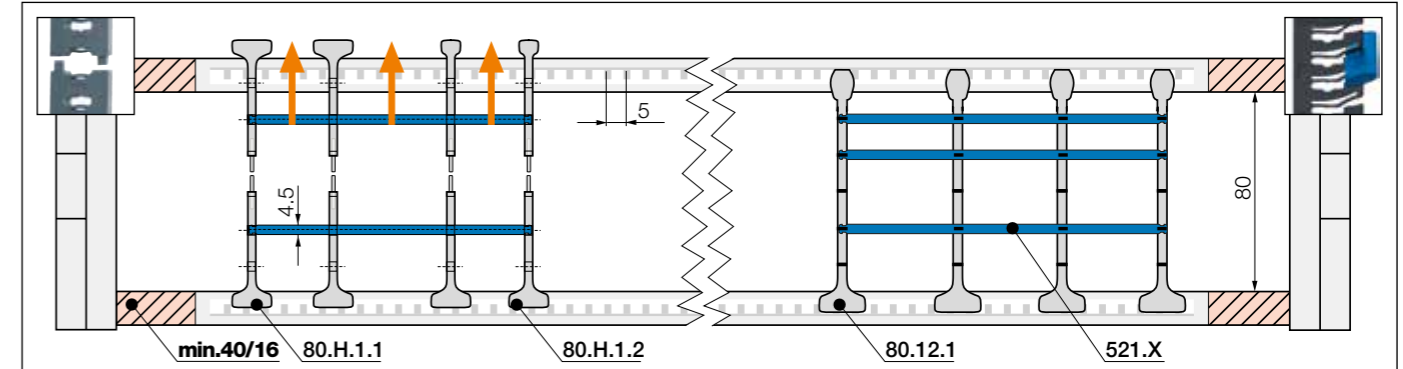

Note: Please be aware of the minimum lateral gap to the side links! **e-tube: 40mm | e-chain®: 16mm**
As standard separators are fitted every 2nd e-chain® link!

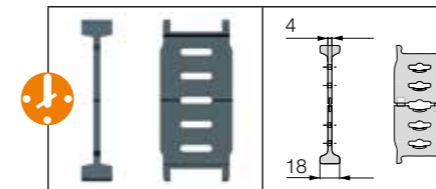

Split separator, wide base/top
unassembled **80.H.1**
assembled **80.H.1.1**

Split separators
In order to fill e-chains® more easily and effectively, these separators can be split in the middle. This allows easier access to middle shelf partitions. Fast assembly and easy retrofit. 2 types available: with wide or narrow top.

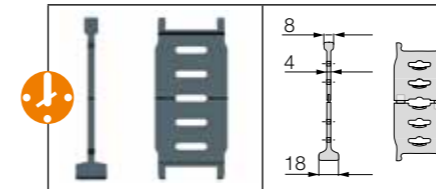

Split separator, narrow top
unassembled **80.H.2**
assembled **80.H.2.1**

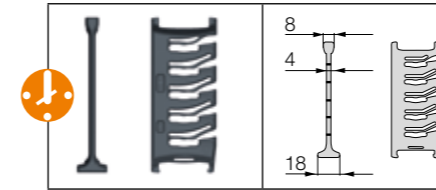

Lean separator¹⁾
unassembled **80.12**
assembled **80.12.1**

Lean separators¹⁾
For quick fitting of shelves in several layers.
1) Note: Please combine maximum 4 lean separators with one shelf. Not suitable for side-mounted e-chains®!

With the lean separator you can quickly insert several layers of cables into the e-chain® and reduce the installation time by up to 50%²⁾.

²⁾ Lean interior separation vs. Standard separator - measured on a 4m long e-chain® fitted with 12 cables in the igus® readychain® factory



More interior separation options

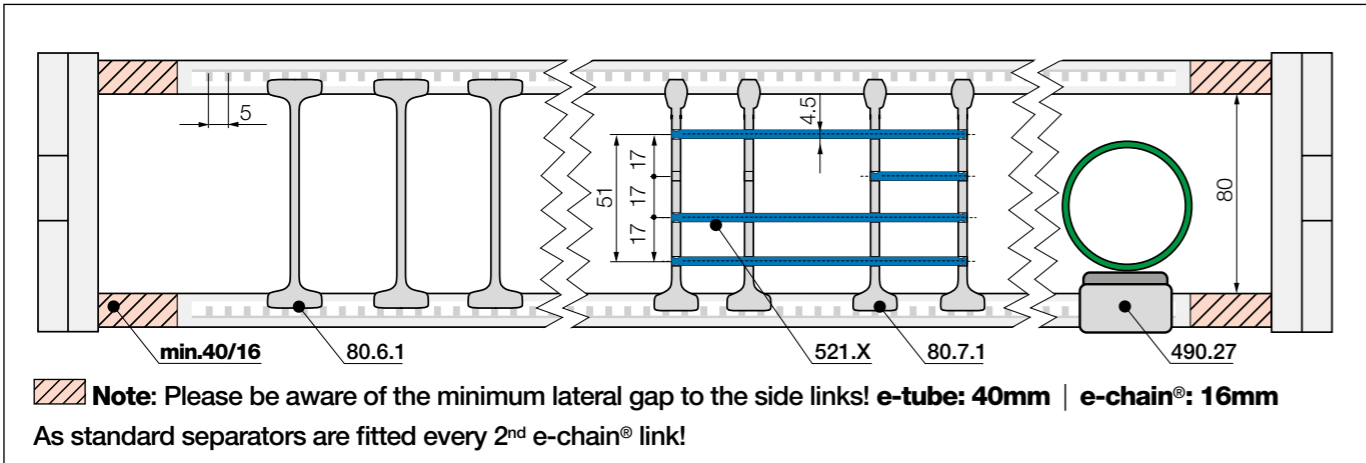

		Notch locking separator*, lockable for e-chains®
	unassembled	80.6
	assembled	80.6.1

Notch locking separator* for increased holding force
Notch locking separators offer higher crossbar opening forces for high humidity and/or large hydraulic hoses. They can be positioned precisely and then locked in position.

		Separator, one end locking
	unassembled	80.7
	assembled	80.7.1

Separator, one end locking
Offset slots for more variability in horizontal subdivisions.

		Rollclip*, for e-chains®
	unassembled	489.27
	assembled	490.27

Rollclip*
Minimises abrasion of sensitive hoses. Simply clamps onto the opening crossbar. The movable rollers compensate for relative movement between the e-chain® and hose.

*Only suitable for e-chains®

TUB

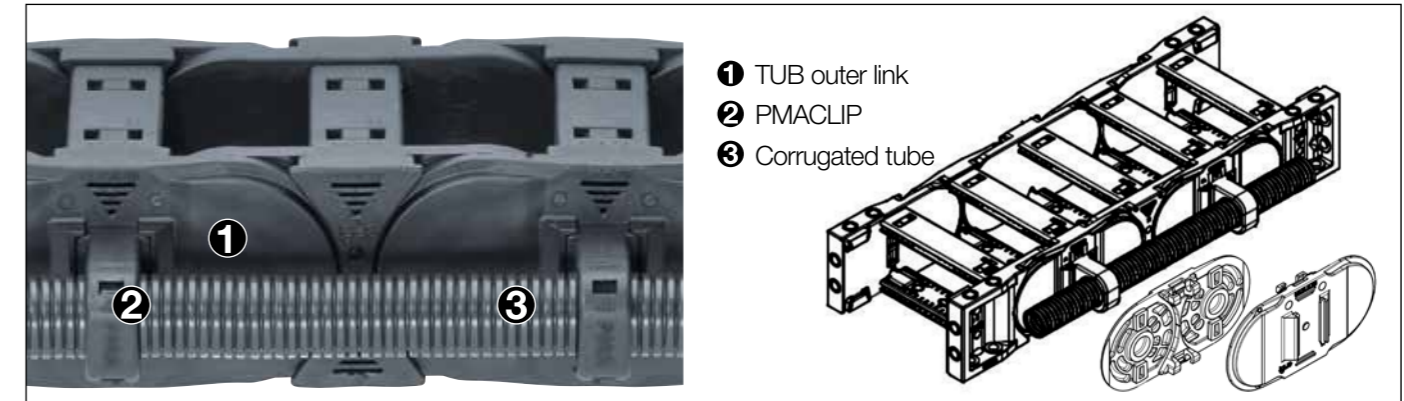

TUB | Safe guidance for corrugated tubes parallel to the e-chain®

- Additional, simple guidance for corrugated tubes on the outside of the e-chain®
- PMACLIP support to be easily clipped on corrugated tubes with nominal widths 17, 23, 29, 36, 48mm
- Easy access to the corrugated tubes, fast replacement of the hoses
- Reduce assembly time and cost - easy to assemble, without any additional screws or tools
- The part number includes the e-chain® with TUB side sections; the PMACLIP support and the hose are ordered separately

Part No. TUB	Part No. TUB	Part No. TUB	For corrugated tube nominal diameter
Outer link right*	Outer link left*	Outer link at both ends*	Ø [mm]
E4.80.XXXTUBR.R.0	E4.80.XXXTUBL.R.0	E4.80.XXXTUB.R.0	17 / 23 / 29 / 36 / 48

*As viewed from the fixed end

Complete Part No. with the width index **XXX** of **B_i** and the minimum bend radius (**R**). Example:

E4.80.10TUBR.150.0 = with TUB outer sections every 2nd right hand link

Product range | PMACLIP | Support, one-piece, with safety clip

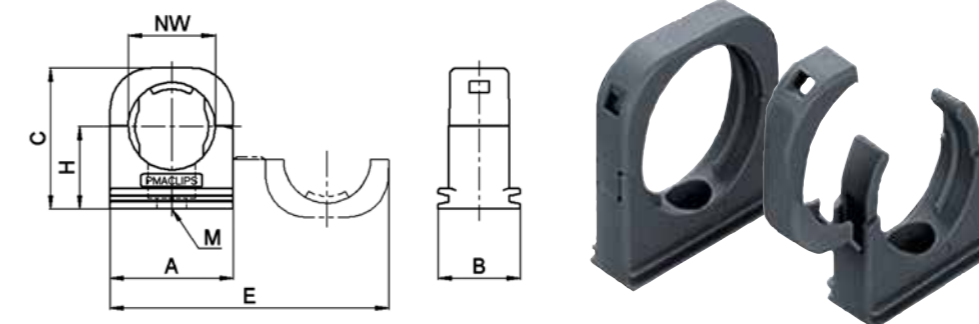

PMACLIP support - one-piece construction with safety clip, suitable for corrugated tubes

Part No.	NW	A	B	C	H	E	M
PMACLIP	Ø [mm]	mm	mm	mm	mm	mm	mm
I-BFH-17-0	17	30.0	20.0	34.0	20.0	68.0	M6
I-BFH-23-0	23	38.5	20.0	42.0	24.0	85.0	M6
I-BFH-29-0	29	45.5	20.0	48.0	27.0	99.0	M6
I-BFH-36-0	36	55.5	20.0	56.0	31.0	119.0	M6
I-BFH-48-0	48	67.5	20.0	68.0	37.0	143.0	M6

Extender crossbar with fixed width

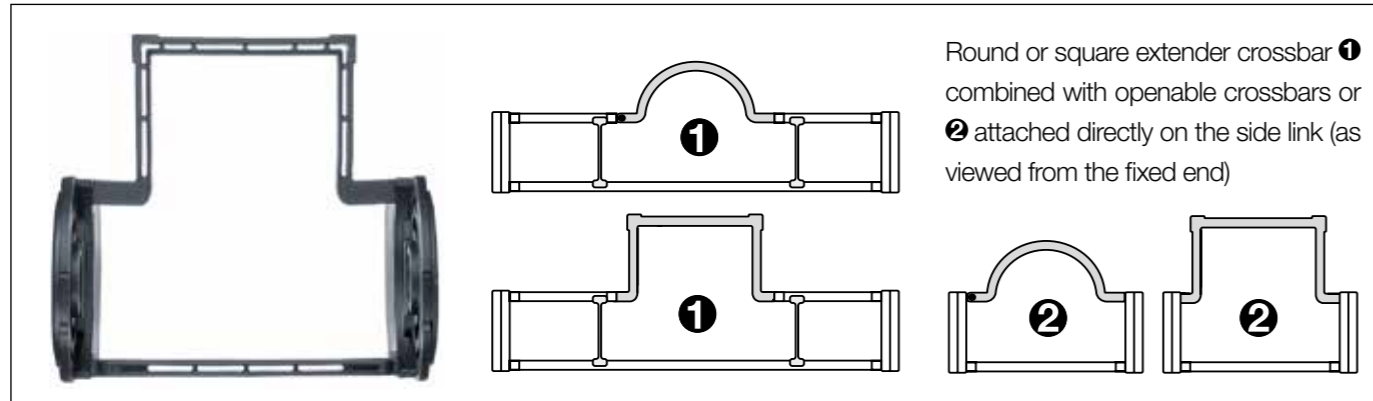

Extender crossbars with fixed width | Safe guiding for large hoses

- Suitable for hoses with a maximum outer diameter of 270mm
- Option 1 extender crossbars with fixed width to combine with openable crossbars
- Option 2 extender crossbars with fixed width attached directly on the side link
- Optionally openable along the inner "Z" or the outer radius "E"
- Gliding with crossbars assembled along the outer radius and a special guide trough

Part No. extender crossbar with fixed width, as individual parts	Hose $\varnothing \leq$ [mm]	Extender crossbar shape	2 Fitted to side link	1 Combine with openable crossbars
450.15RHD115	115	○ round	No	Yes
450.17RD115	115	○ round	Yes	No
450.25D150	150	□ square	Yes	No
450.30D200	200	□ square	Yes	No
450.35D250	220	□ square	Yes	No
450.40D300	270	□ square	Yes	No
450.20HD150	150	□ square	No	Yes
450.25HD200	200	□ square	No	Yes
450.30HD250	220	□ square	No	Yes

Order example: 1 combined with openable crossbars

To receive extender crossbar RHD115 pre-fitted along the outer radius of the-chain®, please add index **E**: E4.80.10/15RHD**E**115/10.R.0

To receive extender crossbar RHD115 pre-fitted along the inner radius of the-chain®, please add index **Z**: E4.80.10/15RHD**Z**115/10.R.0

Order example: 2 fitted to side link

To receive extender crossbar RD115 pre-fitted along the outer radius of the-chain®, please add index **E**: E4.80.17RD**E**115.R.0

To receive extender crossbar RD115 pre-fitted along the inner radius of the-chain®, please add index **Z**: E4.80.17RD**Z**115.R.0

Extension links

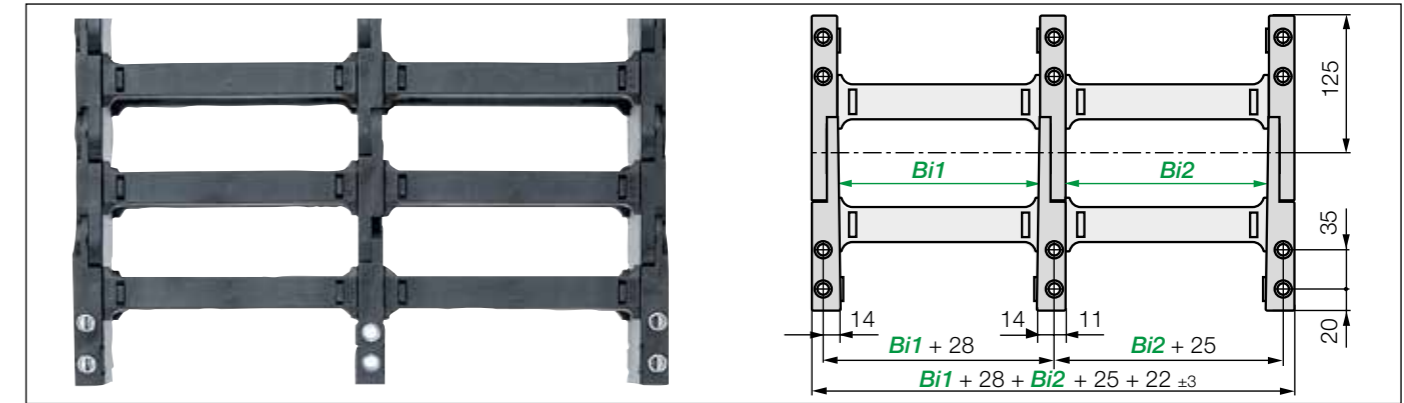

Extension links | For extremely wide e-chains® up to 3.0m

- Virtually unlimited side-by-side extension
- For extremely wide e-chains® up to 3000mm
- Unsupported length FL_G max. can be increased when heavy fill weights are required
- e-chains® and e-tubes can be combined
- Attached with KMA or steel mounting brackets

Part No. Extension link e-chain®	Part No. Extension link e-tube	Part No. extension link as an individual part
		Outer link
E4.80.Bi1/Bi2/Bi3.R.0	R4.80.Bi1/Bi2/Bi3.R.0	E4.80M.01
		Inner link
		E4.80M.02.R.

Complete Part No. with the width index **Bi1/Bi2/Bi3/etc.** and the radius (**R**). Example: E4.80.10/20/10.200.0

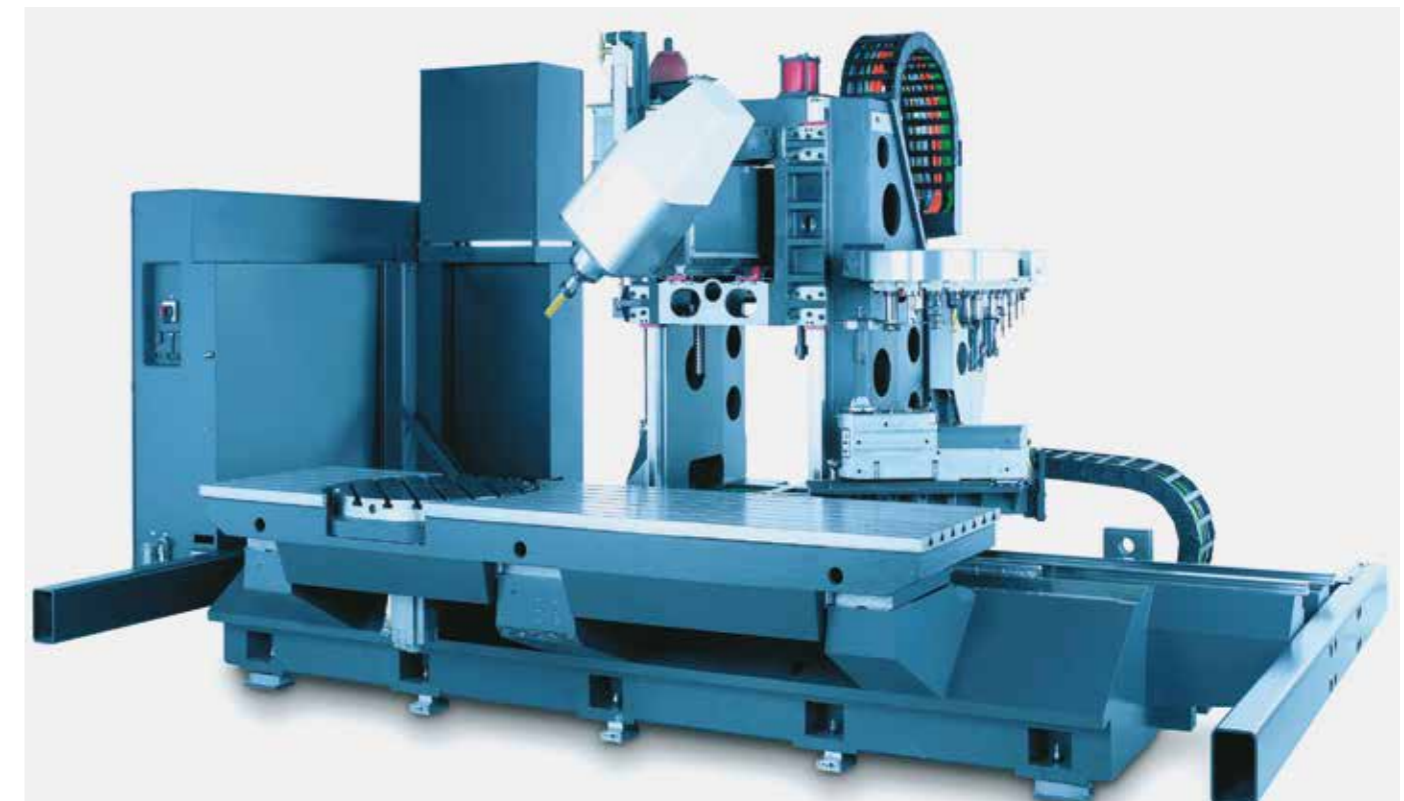

Due to the undercut design igus® E4.1 series feature high lateral stability. High lateral accelerations of up to 8m/s² can be managed on this milling machine for bicycles

E4 snapclip - clip-on tiewrap

- For side-mounted applications, compatible with many E4 e-chains®
 - Serves as a clip-on, lateral guide for hoses and cables on e-chains®
 - The loops can be adjusted as required
- More information ► www.igus.eu/E4.80



Steel support tray for support of the lower run

- Simple one-piece support trays for the lower run
 - To your requirements and specification
 - 4 options available
- More information ► From page 1356



Hot swarf up to +850°C for e-tubes

- Lids and shelves can repel swarf up to +850°C. Special production option with the igus® material igumid HT
 - No hot swarf melting or embedding into the chain
- More information ► www.igus.eu/HT

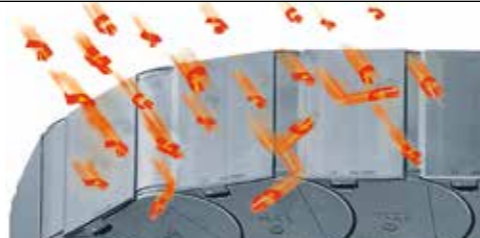

Reduce assembly time - E4 e-chain® opener

- e-chain® opener tools for easy opening and closing of e-chains®
 - Simple opening and closing of e-chain® crossbars
 - Also for use in hard to reach locations
 - Significant assembly time reduction
- More information ► www.igus.eu/E4savetime



Roller crossbars - increase the service life of cables and hoses

- Significantly reduce jacket abrasion of very stiff cables and hoses with rolling contact surfaces equipped with tribo-optimised bearings
 - For sensitive hoses in restricted space
 - Usable along the inner and/or outer radius, retrofit possible
- More information ► upon request



Also available for heavy-duty applications | Series 5050HD·R9850HD

Heavy-duty version - for very long travels or heavy fill weights

- High torsional rigidity and tensile strength
 - Tough steel mounting brackets
 - For long-term operation in very humid environments
- Series 5050HD·R9850HD - more information ► www.igus.eu/5050HD



igus® E4.1 in an earth drilling machine. Standing installation, it defies strong vibrations. Thanks to plastic, no loose parts such as rivets or screws

Option: E4Q - the next generation of easy-to-assemble igus® e-chains®

The latest E4Q e-chains® generation combines proven design features of the 12-year old, robust E4.1 e-chains® standard with new bionic design elements and a novel opening mechanism. This gives the E4Q an even longer service life and significantly improved ease of installation.

- Opening and closing completely without tools
 - Greater strength and longer unsupported lengths
 - Lighter e-chain® links due to material saving
 - Optional noise dampening - new system for noise reduction
- More information ► From page 580



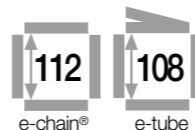

e-chains® | Series E4.112 | Crossbars every link (crossbars removable along the inner and outer radius)
e-tubes | Series R4.112 | Fully enclosed (lids openable along the outer radius, from one side)

Part No.	Bi	Ba	E4.112	R4.112	Part No.	Bi	Ba	E4.112	R4.112
e-chains® / e-tubes	[mm]	[mm]	[kg/m]	[kg/m]	e-chains® / e-tubes	[mm]	[mm]	[kg/m]	[kg/m]
E4. - 112.05.R.0	50	102	≈7.78	-	E4. - 112.28.R.0	287	339	≈8.88	-
E4. - 112.055.R.0	55	107	≈7.81	-	E4. R4. 112.30.R.0	300	352	≈8.97	≈11.42
E4. - 112.06.R.0	65	117	≈7.84	-	E4. - 112.31.R.0	312	364	≈9.00	-
E4. - 112.07.R.0	75	127	≈7.88	-	E4. - 112.32.R.0	325	377	≈9.06	-
E4. - 112.08.R.0	87	139	≈7.94	-	E4. - 112.33.R.0	337	389	≈9.14	-
E4. - 112.10.R.0	100	152	≈7.99	-	E4. R4. 112.35.R.0	350	402	≈9.27	≈12.07
E4. - 112.11.R.0	112	164	≈8.07	-	E4. - 112.36.R.0	362	414	≈9.21	-
E4. - 112.12.R.0	125	177	≈8.12	-	E4. - 112.37.R.0	375	427	≈9.27	-
E4. - 112.13.R.0	137	189	≈8.20	-	E4. - 112.38.R.0	387	439	≈9.35	-
E4. - 112.15.R.0	150	202	≈8.23	-	E4. R4. 112.40.R.0	400	452	≈9.52	≈12.71
E4. - 112.16.R.0	162	214	≈8.30	-	E4. - 112.41.R.0	412	464	≈9.47	-
E4. - 112.169.R.0	169	222	≈8.35	-	E4. - 112.42.R.0	425	477	≈9.66	-
E4. - 112.17.R.0	175	227	≈8.38	-	E4. - 112.43.R.0	437	489	≈9.56	-
E4. - 112.182.R.0	182	235	≈8.41	-	E4. - 112.45.R.0	450	502	≈9.77	-
E4. - 112.18.R.0	187	239	≈8.45	-	E4. - 112.46.R.0	462	514	≈9.74	-
E4. R4. 112.20.R.0	200	252	≈8.49	≈10.15	E4. - 112.47.R.0	475	527	≈9.76	-
E4. - 112.207.R.0	207	260	≈8.52	-	E4. - 112.48.R.0	487	539	≈9.92	-
E4. - 112.21.R.0	212	264	≈8.53	-	E4. R4. 112.50.R.0	500	552	≈9.98	≈13.99
E4. - 112.22.R.0	225	277	≈8.58	-	E4. - 112.51.R.0	512	564	≈9.92	-
E4. - 112.23.R.0	237	289	≈8.65	-	E4. - 112.52.R.0	525	577	≈10.03	-
E4. R4. 112.25.R.0	250	302	≈8.72	≈10.79	E4. - 112.53.R.0	537	589	≈10.09	-
E4. - 112.26.R.0	262	314	≈8.78	-	E4. - 112.55.R.0	550	602	≈10.36	-
E4. - 112.27.R.0	275	327	≈8.84	-	E4. - 112.60.R.0	600	652	≈10.51	-

*Radius not available for e-tubes **Radius available for e-tubes with technical limitations, upon request

Available bend radii

R [mm] | 200* | 250** | 300** | 350 | 400 | 450 | 500 | 550 | 600 | 750 | 1,000 |

Complete Part No. with required radius (R). Example:

E4.112.30.300.0 = crossbars every link / R4.112.30.300.0 = fully enclosed

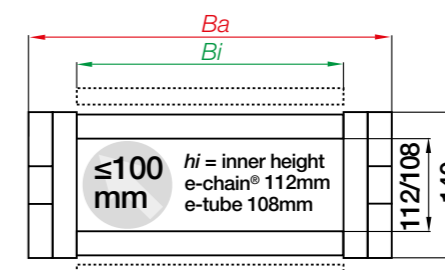
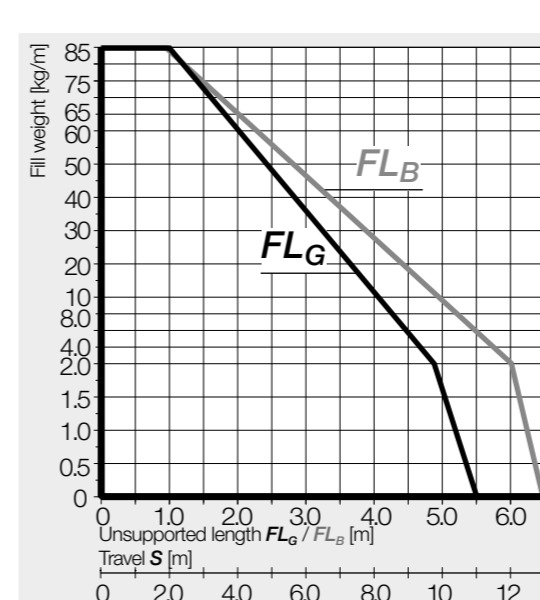
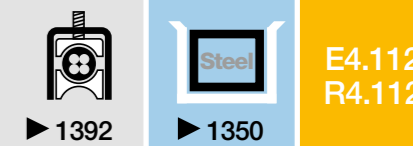

E4.112 Inner height [mm]	112
R4.112 Inner height [mm]	108
Pitch [mm/link]	143
Links/m	7
corresponds to [mm]	1,001
e-chain® length	$L_K = S/2 + K$

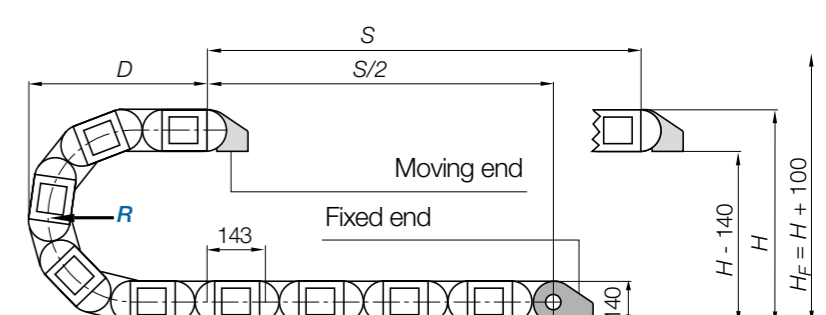

R	200*	250**	300**	350	400	450	500	550	600	750	1,000
H	545	645	745	845	945	1,045	1,145	1,245	1,345	1,645	2,145
D	415	465	515	565	615	665	715	765	815	965	1,215
K	915	1,075	1,230	1,390	1,545	1,700	1,860	2,015	2,175	2,645	3,430

The required clearance height: $H_F = H + 100$ mm (with 5.0kg/m fill weight)

*Radius not available for e-tubes **Radius available for e-tubes with technical limitations, upon request

Gliding applications | For travel lengths from 14m to max. 450m

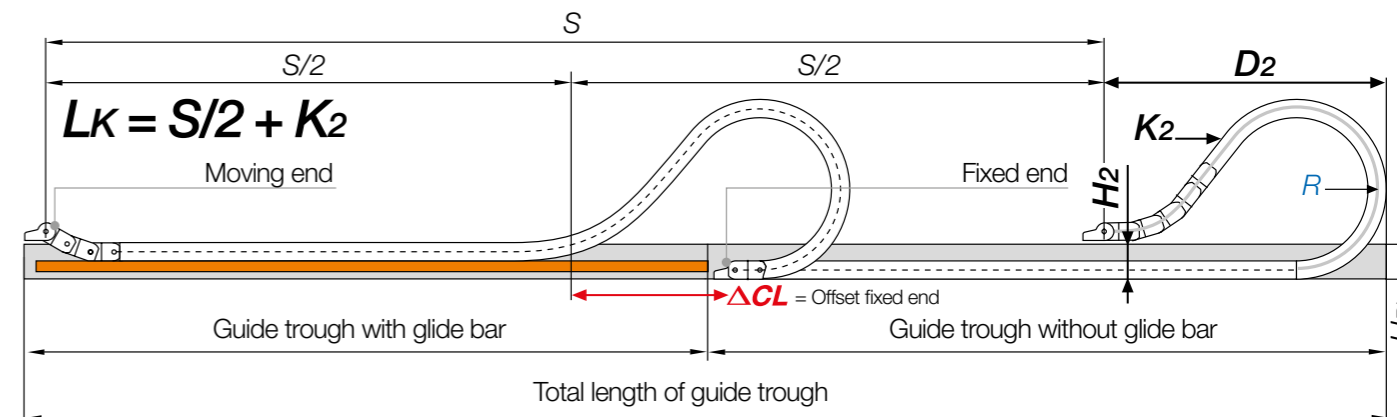

Note: We recommend the project planning of such a system to be carried out by igus®.

In case of travels between 11 and 14m we recommend an e-chain® with a longer unsupported length.

R	200*	250**	300**	350	400	450	500	550	600	750	1,000
H ₂	325	325	325	325	325	325	325	325	325	-	-
D ₂	900	1,000	1,100	1,250	1,450	1,600	1,700	1,900	2,050	-	-
K ₂	1,573	1,716	1,859	2,288	2,574	2,860	3,146	3,432	3,861	-	-
ΔCL	450	500	550	650	800	900	950	1,100	1,200	-	-

*Radius not available for e-tubes **Radius available for e-tubes with technical limitations, upon request

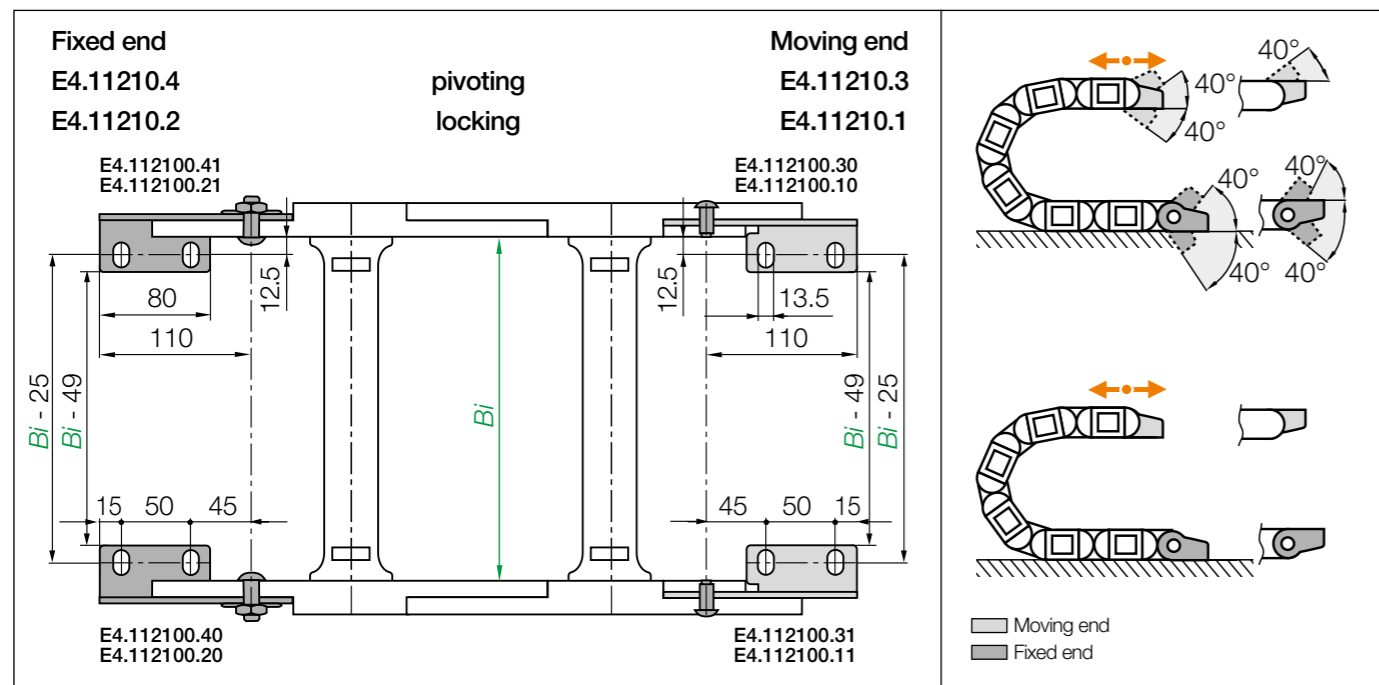

KMA pivoting | Recommended for unsupported and gliding applications
Steel locking | Recommended for vertical hanging and standing applications

Part No. full set	Part No. full set	Description
steel pivoting	steel locking	Mounting bracket
E4.11210. 1 .34.VS E45	E4.11210. 1 .12.VS E45	Full set (both ends) ending with outer side link, screwed - standard
E4.11210. 2 .34.VS E45	E4.11210. 2 .12.VS E45	Full set (both ends) beginning with outer side link (moving end) - ending with inner side link (fixed end), screwed - standard

Stainless steel version available. Please add the index **.E45!** (Material: AISI 316Ti stainless steel)

Note: The e-chains® may end with either an inner or an outer side link. An outer side link should always be the first e-chain® link at the moving end. Please specify the index **1** (for odd) or **2** (for even) depending on an even or odd number of links required. For the best appearance, make sure the e-chain® ends with **1** outer side links whenever possible. (with odd number of links)

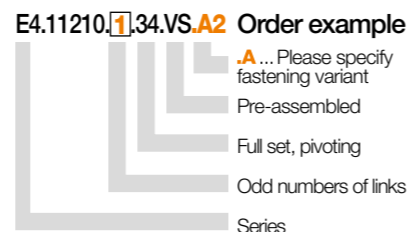
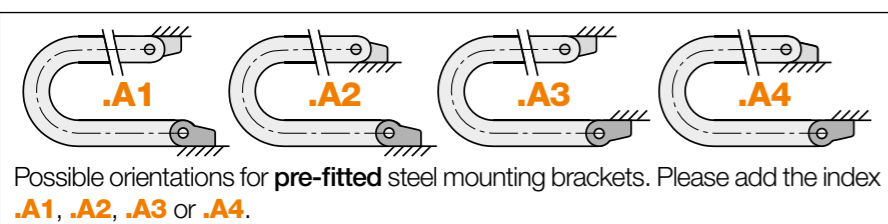
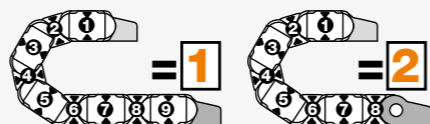

Strain relief e.g. clamps, tiwrap plates, nuggets and clips are available from stock. The complete chainfix range with ordering options ► From page 1392

Previous generation of interior separation with other options ► www.igus.eu/E4.112

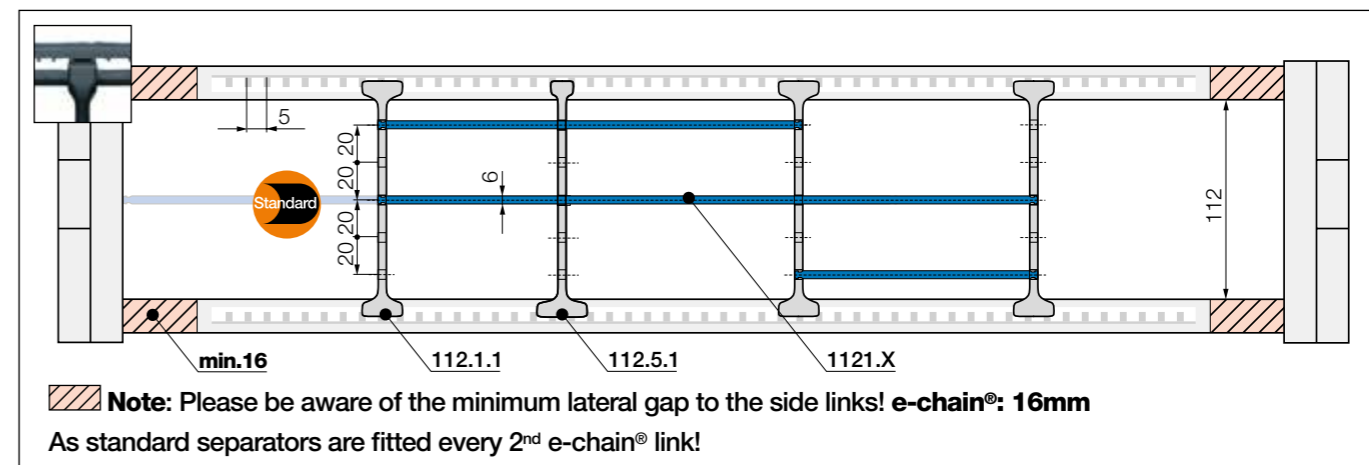

		Standard separator, wide base unassembled 112.1 assembled 112.1.1
		Notch separator for notched crossbar unassembled 112.5 assembled 112.5.1
		Shelf, lockable unassembled 1120.X assembled 1121.X

Standard - for any application

Separator with a wide base for maximum holding force.

Locks securely in preset increments

Notch separator for exact positioning. Recommended for side-mounted applications.

Horizontal separation

Full-width shelf locks securely into separators at both ends, giving a fixed width. Can be used as full-width or partial shelf.

Shelves

Width = X [mm]



X [mm]	unassembled	assembled	X [mm]	unassembled	assembled	X [mm]	unassembled	assembled
050	1120.050	1121.050	150	1120.150	1121.150	300	1120.300	1121.300
065	1120.065	1121.065	175	1120.175	1121.175	350	1120.350	1121.350
075	1120.075	1121.075	200	1120.200	1121.200	375	1120.375	1121.375
100	1120.100	1121.100	225	1120.225	1121.225	387	1120.387	1121.387
125	1120.125	1121.125	250	1120.250	1121.250	450	1120.450	1121.450

Interior separation | Increase cable service life | Only for e-tubes

Previous generation of interior separation with other options ► www.igus.eu/R4,112

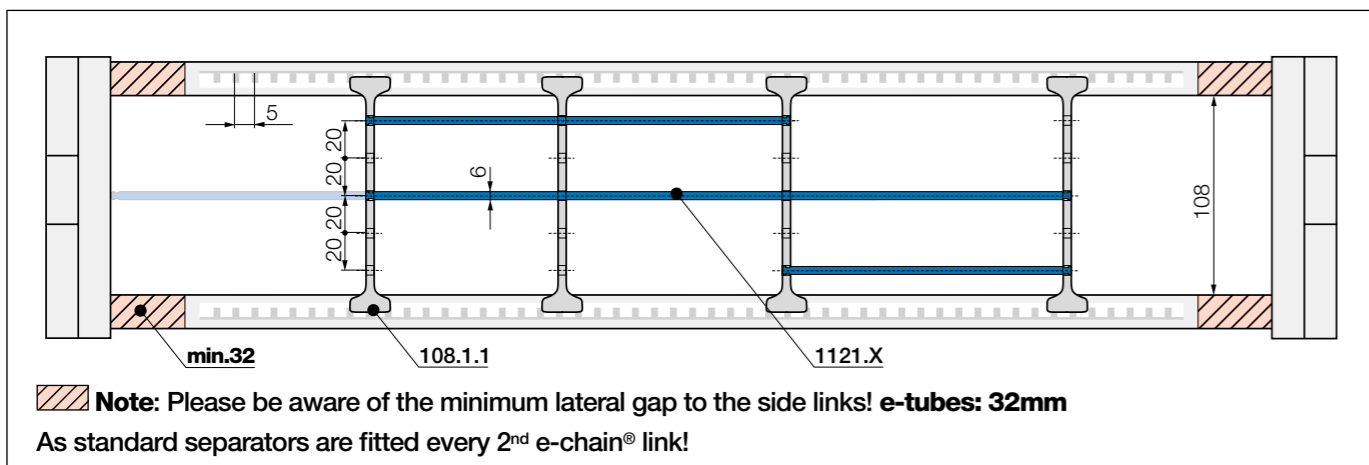

Standard separator, wide base

unassembled	108.1
assembled	108.1.1

Standard - for any application
Separator with a wide base for maximum holding force.

Shelf, lockable

unassembled	1120.X
assembled	1121.X

Horizontal separation
Full-width shelf locks securely into separators at both ends, giving a fixed width. Can be used as full-width or partial shelf.

Shelves Width = X [mm]	X [mm]	unassembled	assembled	X [mm]	unassembled	assembled	X [mm]	unassembled	assembled
		050	1120.050	1121.050	150	1120.150	1121.150	300	1120.300
	065	1120.065	1121.065	175	1120.175	1121.175	350	1120.350	1121.350
	075	1120.075	1121.075	200	1120.200	1121.200	375	1120.375	1121.375
	100	1120.100	1121.100	225	1120.225	1121.225	387	1120.387	1121.387
	125	1120.125	1121.125	250	1120.250	1121.250	450	1120.450	1121.450



Compact design, custom configuration: two nested E4.112 e-chains® each around 12m long carry very heavy fill weights

Interior separation | To allow faster filling

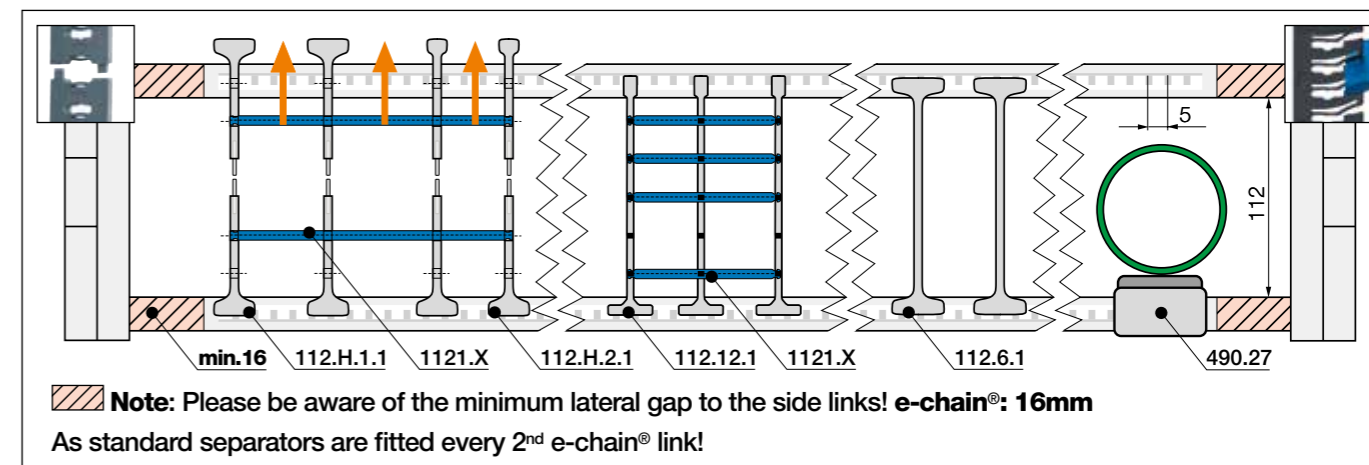

Split separator, wide base/top*

unassembled	112.H.1
assembled	112.H.1.1

Split separators*
In order to fill e-chains® more easily and effectively, these separators can be split in the middle. This allows easier access to middle shelf partitions. Fast assembly and easy retrofit. 2 types available: with wide or narrow top.

Split separator, narrow top*

unassembled	112.H.2
assembled	112.H.2.1

Lean separator*¹⁾

unassembled	112.12
assembled	112.12.1

Lean separators*¹⁾
For quick fitting of shelves in several layers.
1) Note: Please combine maximum 4 lean separators with one shelf. Not suitable for side-mounted e-chains®!

With the lean separator you can quickly insert several layers of cables into the e-chain® and reduce the installation time by up to 50%²⁾.

2) Lean interior separation vs. Standard separator - measured on a 4m long e-chain® fitted with 12 cables in the igus® readychain® factory



More interior separation options | Only for e-chains®

Notch locking separator*, lockable for e-chains®

unassembled	112.6
assembled	112.6.1

Notch locking separator* for increased holding force
Notch locking separators* offer higher crossbar opening forces for high humidity and/or large hydraulic hoses. They can be positioned precisely and then locked in position.

Rollclip*, for e-chains®

unassembled	489.27
assembled	490.27

Rollclip*
Minimises abrasion of sensitive hoses. Simply clamps onto the opening crossbar. The movable rollers compensate for relative movement between the e-chain® and hose.

*Only suitable for e-chains®

Extender crossbar with fixed width

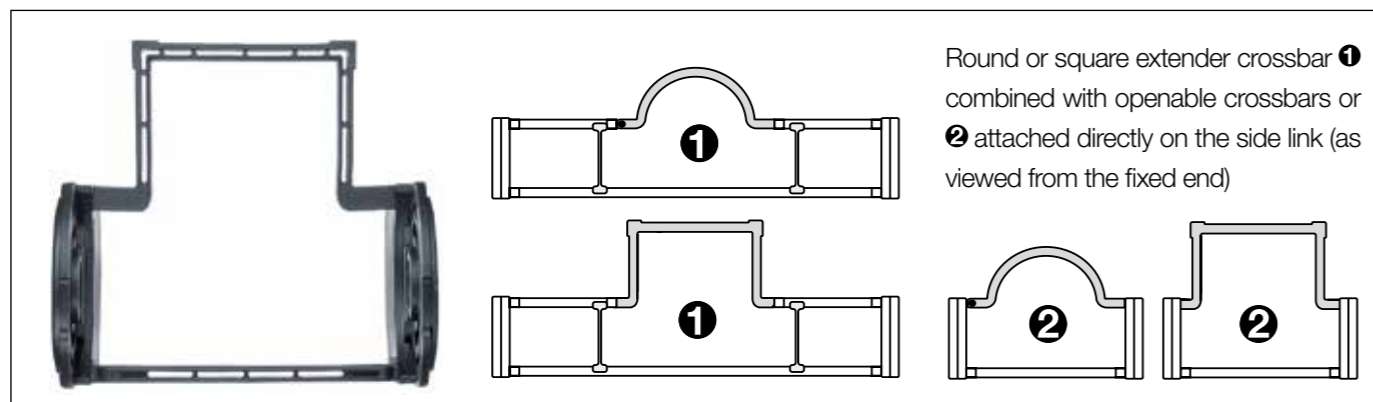

Extender crossbars with fixed width | Safe guiding for large hoses

- Suitable for hoses with a maximum outer diameter of 270mm
- Option ❶ extender crossbars with fixed width to combine with openable crossbars
- Option ❷ extender crossbars with fixed width attached directly on the side link
- Optionally openable along the inner "Z" or the outer radius "E"
- Gliding with crossbars assembled along the outer radius and a special guide trough

Part No. extender crossbar with fixed width, as individual parts	Hose $\varnothing \leq$ [mm]	Extender crossbar shape	❷ Fitted to side link	❶ Combine with openable crossbars
450.15RHD115	115	○ round	No	Yes
450.17RD115	115	○ round	Yes	No
450.25D150	150	□ square	Yes	No
450.30D200	200	□ square	Yes	No
450.35D250	220	□ square	Yes	No
450.40D300	270	□ square	Yes	No
450.20HD150	150	□ square	No	Yes
450.25HD200	200	□ square	No	Yes
450.30HD250	220	□ square	No	Yes

Order example: ❶ combined with openable crossbars

To receive extender crossbar RHD115 pre-fitted along the outer radius of the-chain®, please add index **E**: E4.112.10/15RHD**E**115/10.**R**.0

To receive extender crossbar RHD115 pre-fitted along the inner radius of the-chain®, please add index **Z**: E4.112.10/15RHD**Z**115/10.**R**.0

Order example: ❷ fitted to side link

To receive extender crossbar RD115 pre-fitted along the outer radius of the-chain®, please add index **E**: E4.112.17RD**E**115.**R**.0

To receive extender crossbar RD115 pre-fitted along the inner radius of the-chain®, please add index **Z**: E4.112.17RD**Z**115.**R**.0

Extension links

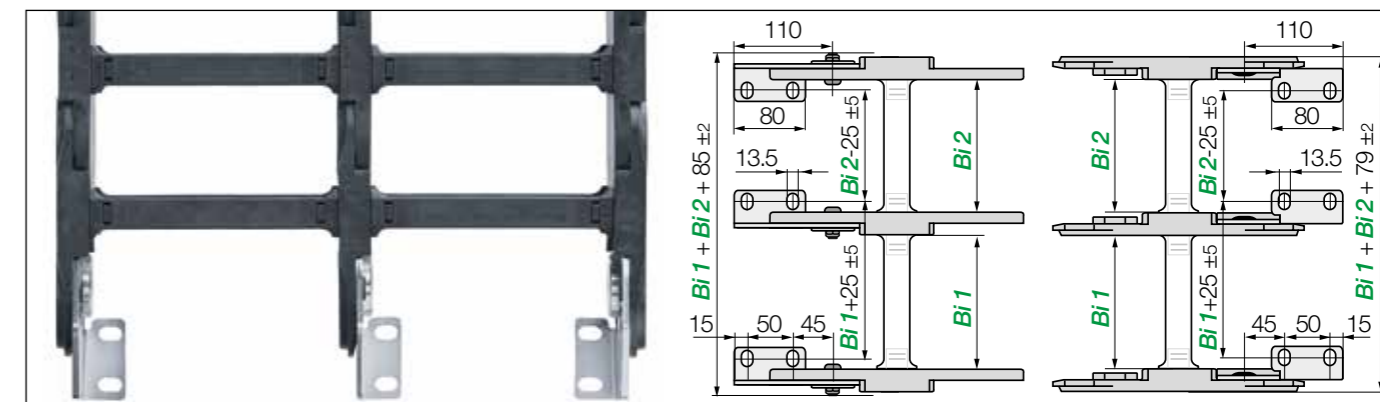

Extension links | For extremely wide e-chains® up to 3.0m

- Virtually unlimited side-by-side extension
- For extremely wide e-chains® up to 3000mm
- Unsupported length FL_G max. can be increased when heavy fill weights are required
- e-chains® and e-tubes can be combined
- Attached with KMA or steel mounting brackets

Part No.	Part No.	Part No.
Extension link e-chain®	Extension link e-tube	Extension link as an individual part
E4.112. Bi1/Bi2/Bi3 . R .0	R4.112. Bi1/Bi2/Bi3 . R .0	6022. R .

Complete Part No. with the width index **Bi1/Bi2/Bi3/etc.** and the radius (**R**). Example: E4.112.10/20/10.200.0

Hot swarf up to +850°C for e-tubes

- Lids and shelves can repel swarf up to +850°C. Special production option with the igus® material igumid HT
 - No hot swarf melting or embedding into the chain
- More information ► www.igus.eu/HT



Reduce assembly time - E4 e-chain® opener

- e-chain® opener tools for easy opening and closing of e-chains®
 - Simple opening and closing of e-chain® crossbars
 - Also for use in hard to reach locations
 - Significant assembly time reduction
- More information ► www.igus.eu/E4savetime



Roller crossbars - increase the service life of cables and hoses

- Significantly reduce jacket abrasion of very stiff cables and hoses with rolling contact surfaces equipped with tribo-optimised bearings
 - For sensitive hoses in restricted space
 - Usable along the inner and/or outer radius, retrofit possible
- More information ► upon request





... E4.162

e-chains® | Series E4.162 | Crossbars every link (crossbars removable along the inner and outer radius)

Part No. e-chains®	Bi [mm]	Ba [mm]	E4.162 [kg/m]	Part No. e-chains®	Bi [mm]	Ba [mm]	E4.162 [kg/m]
E4.162 .20. R.0	200	256	≈ 10.45	E4.162 .40. R.0	400	456	≈ 11.51
E4.162 .25. R.0	250	306	≈ 10.74	E4.162 .45. R.0	450	506	≈ 11.65
E4.162 .30. R.0	300	356	≈ 10.99	E4.162 .50. R.0	500	556	≈ 11.83
E4.162 .32. R.0	325	381	≈ 11.02	E4.162 .55. R.0	550	606	≈ 12.11
E4.162 .35. R.0	350	406	≈ 11.21	E4.162 .60. R.0	600	656	≈ 12.45

Available bend radii

R [mm] | 250 | 300 | 350 | 400 | 450 | 500 | 550 | 600 | 750 | 1,000 |

Complete Part No. with required radius (R). Example: E4.162.40.350.0 = crossbars every link

Reduce assembly time - E4 e-chain® opener

- e-chain® opener tools for easy opening and closing of e-chains®
 - Simple opening and closing of e-chain® crossbars
 - Also for use in hard to reach locations
 - Significant assembly time reduction
- More information ► www.igus.eu/E4savetime

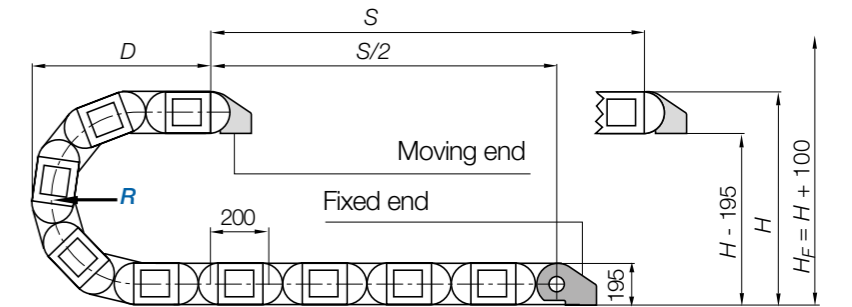
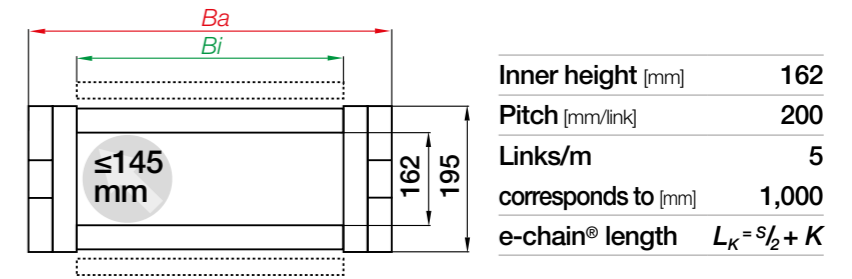
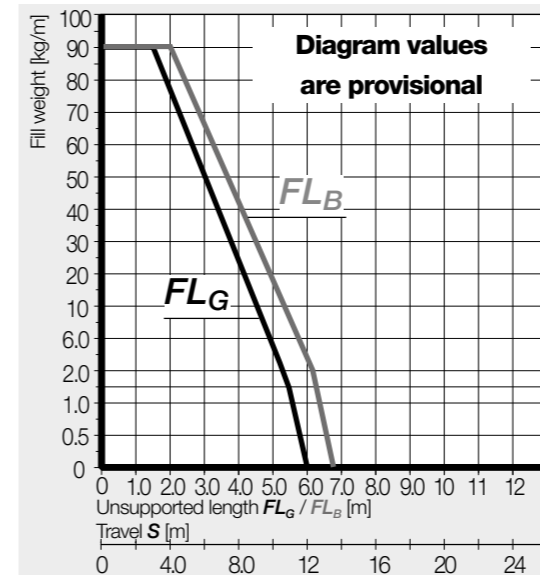

R	250	300	350	400	450	500	550	600	750	1,000
H	700	800	900	1,000	1,100	1,200	1,300	1,400	1,700	2,200
D	648	698	748	798	848	898	948	998	1,148	1,398
K	1,190	1,345	1,500	1,660	1,815	1,975	2,130	2,285	2,760	3,545

The required clearance height: $H_F = H + 100\text{mm}$ (with 5.0kg/m fill weight)

Gliding applications | For travel lengths from 14m to max. 450m

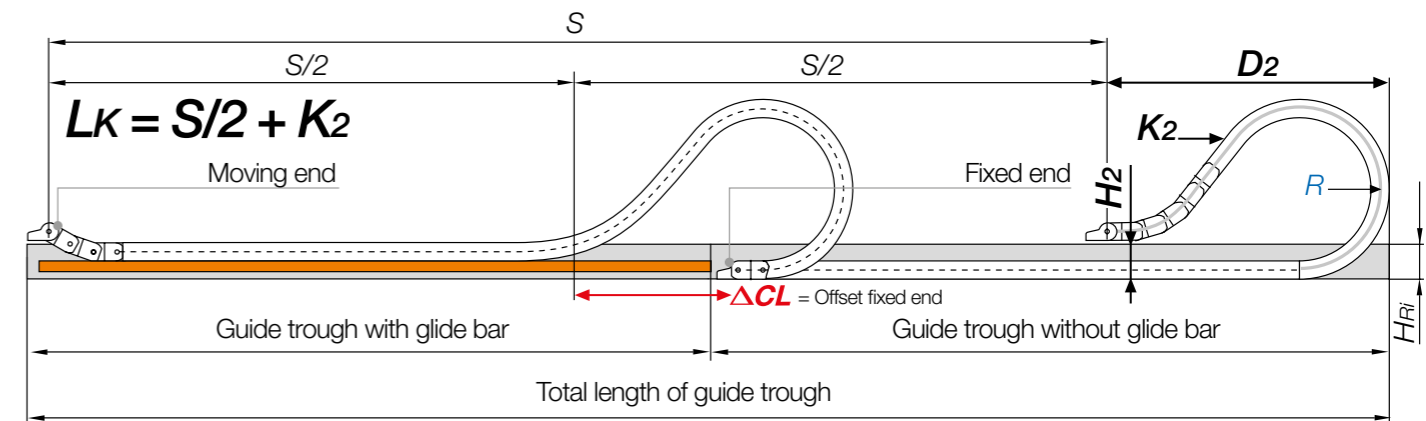

Note: We recommend the project planning of such a system to be carried out by igus®.

In case of travels between 12 and 14m we recommend an e-chain® with a longer unsupported length.

R	250	300	350	400	450	500	550	600	750	1,000
H ₂	*	580	580	580	580	580	580	580	**	**
D ₂	*	950	1,050	1,350	1,600	1,950	2,050	2,400	**	**
K ₂	*	1,600	1,800	2,400	2,800	3,200	3,400	3,800	**	**
ΔCL	*	300	350	600	800	1,100	1,150	1,450	**	**

*Values such as unsupported applications **Values upon request

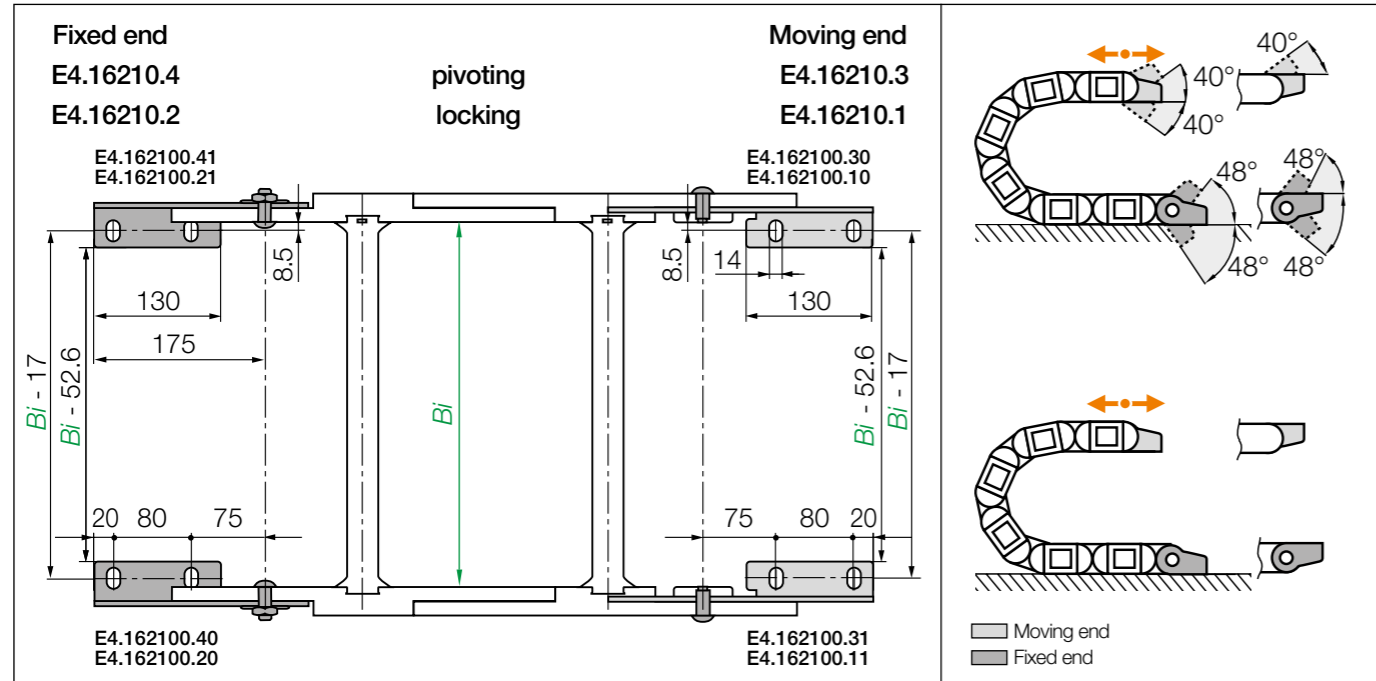

KMA pivoting | Recommended for unsupported and gliding applications
Steel locking | Recommended for vertical hanging and standing applications

Part No. full set	Part No. full set	Description
steel pivoting	steel locking	Mounting bracket
E4.16210.1.34.VS.E45	E4.16210.1.12.VS E45	Full set (both ends) ending with outer side link, screwed - standard
E4.16210.2.34.VS.E45	E4.16210.2.12.VS E45	Full set (both ends) beginning with outer side link (moving end) - ending with inner side link (fixed end), screwed - standard

Stainless steel version available. Please add the index **.E45!** (Material: AISI 316Ti stainless steel)

Note: The e-chains® may end with either an inner or an outer side link. An outer side link should always be the first e-chain® link at the moving end. Please specify the index **1** (for odd) or **2** (for even) depending on an even or odd number of links required. For the best appearance, make sure the e-chain® ends with **1** outer side links whenever possible. (with odd number of links)

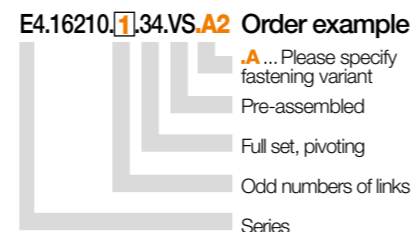
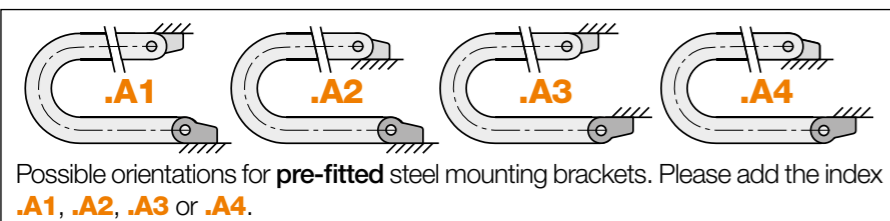
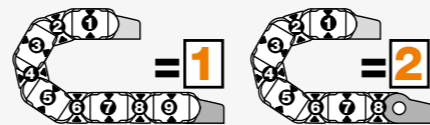

Strain relief e.g. clamps, tiwrap plates, nuggets and clips are available from stock. The complete chainfix range with ordering options ▶ From page 1392

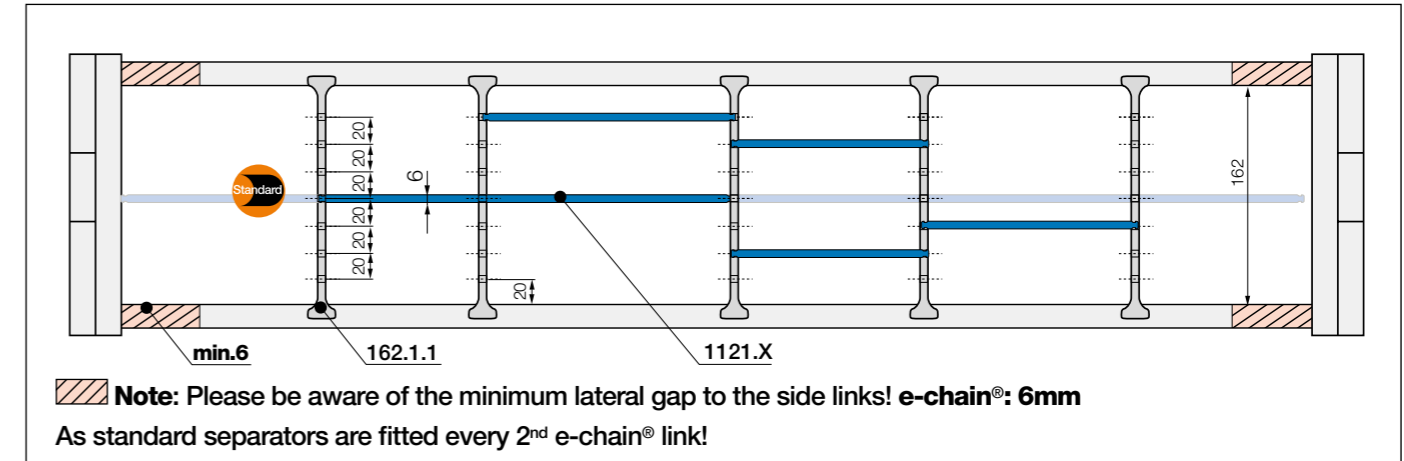

Standard separator, wide base	Standard separator, wide base
unassembled 162.1	unassembled 162.1
assembled 162.1.1	assembled 162.1.1

Shelf, lockable	Shelf, lockable
unassembled 1120.X	unassembled 1120.X
assembled 1121.X	assembled 1121.X

Standard - for any application
 Separator with a wide base for maximum holding force.

Horizontal separation
 Full-width shelf locks securely into separators at both ends, giving a fixed width. Can be used as full-width or partial shelf.



X [mm]	unassembled	assembled	X [mm]	unassembled	assembled	X [mm]	unassembled	assembled
050	1120.050	1121.050	150	1120.150	1121.150	300	1120.300	1121.300
065	1120.065	1121.065	175	1120.175	1121.175	350	1120.350	1121.350
075	1120.075	1121.075	200	1120.200	1121.200	375	1120.375	1121.375
100	1120.100	1121.100	225	1120.225	1121.225	387	1120.387	1121.387
125	1120.125	1121.125	250	1120.250	1121.250	450	1120.450	1121.450

E4.1 | Series 800 | Product range

For tough applications, very large inner height



e-chains® | Series 800 | Crossbars every link (crossbars removable along the inner and outer radius)

Part No.	Bi	Ba	800	Part No.	Bi	Ba	800
e-chains®	[mm]	[mm]	[kg/m]	e-chains®	[mm]	[mm]	[kg/m]
800.20.R.0	200	260	≈ 15.09	800.40.R.0	400	460	≈ 16.74
800.25.R.0	250	310	≈ 15.50	800.45.R.0	450	510	≈ 16.88
800.30.R.0	300	360	≈ 15.89	800.50.R.0	500	560	≈ 17.23
800.32.R.0	325	385	≈ 16.05	800.55.R.0	550	610	≈ 17.63
800.35.R.0	350	410	≈ 16.22	800.60.R.0	600	660	≈ 18.19

Available bend radii

R [mm] | 325 | 350 | 400 | 450 | 500 | 600 | 750 | 1,000 |

Complete Part No. with required radius (R). Example: 800.40.400.0 = crossbars every link

Reduce assembly time - E4 e-chain® opener

- e-chain® opener tools for easy opening and closing of e-chains®
 - Simple opening and closing of e-chain® crossbars
 - Also for use in hard to reach locations
 - Significant assembly time reduction
- More information ► www.igus.eu/E4savetime



E4.1 | Series 800 | Installation dimensions

Unsupported applications | Short travels

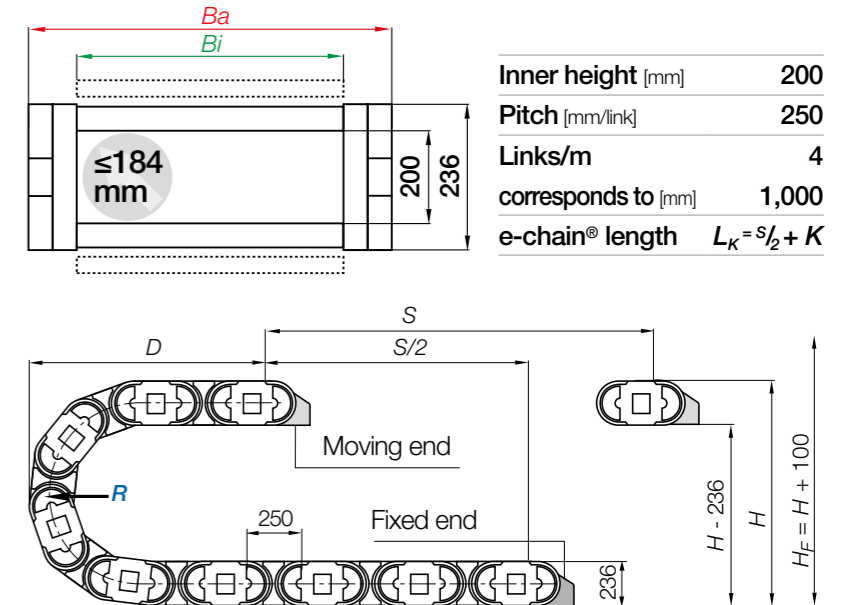
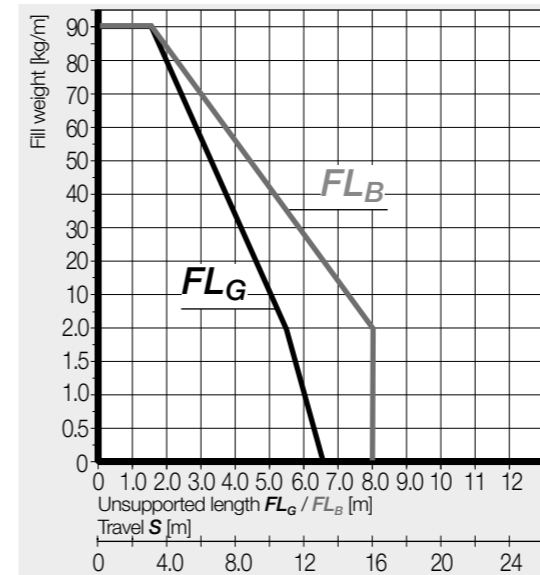

R	325	350	400	450	500	600	750	1,000
H	886	936	1,036	1,136	1,236	1,436	1,736	2,236
D	818	843	893	943	993	1,093	1,243	1,493
K	1,525	1,600	1,760	1,915	2,075	2,385	2,860	3,645

The required clearance height: $H_F = H + 100\text{mm}$ (with 5.0kg/m fill weight)

Gliding applications | For travel lengths from 15m to max. 450m

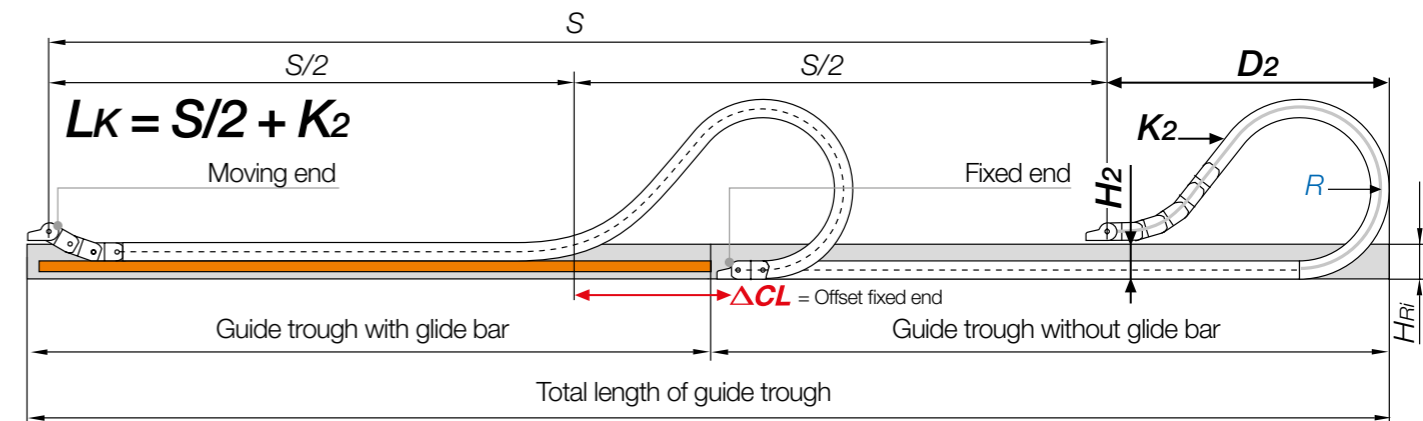

Note: We recommend the project planning of such a system to be carried out by igus®.

In case of travels between 12 and 15m we recommend an e-chain® with a longer unsupported length.

R	325	350	400	450	500	600	750	1,000
H ₂	580	580	580	580	580	580	580	580
D ₂ ⁺²⁵	1,030	1,080	1,380	1,610	2,000	2,480	*	*
K ₂	2,000	2,000	2,500	3,000	3,250	4,000	*	*
CL	250	300	550	750	1,050	1,400	*	*

*Values upon request

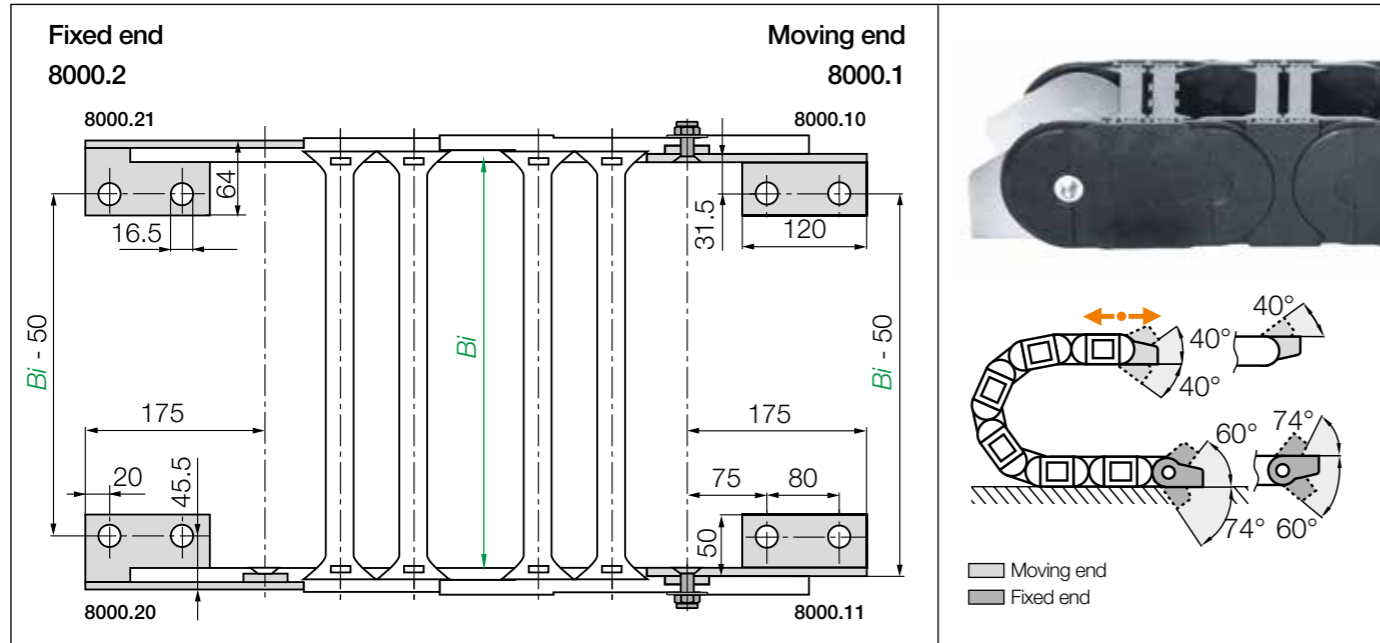

Steel pivoting | For unsupported, gliding, vertical standing and vertical hanging applications

Part No. full set	Description
steel pivoting	Mounting bracket
8000.1.12.VS E45	Full set (both ends) ending with outer side link, screwed - standard
8000.3.12.VS E45	Full set (both ends) beginning with outer side link (moving end) - ending with inner side link (fixed end), screwed - standard

Stainless steel version available. Please add the index **.E45!** (Material: AISI 316Ti stainless steel)

Note: The e-chains® may end with either an inner or an outer side link. An outer side link should always be the first e-chain® link at the moving end. Please specify the index **1** (for odd) or **3** (for even) depending on an even or odd number of links required. For the best appearance, make sure the e-chain® ends with **1** outer side links whenever possible. (with odd number of links)

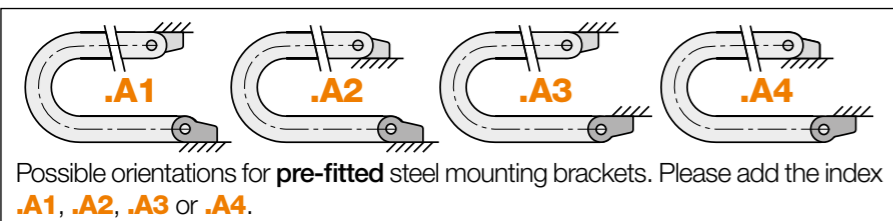
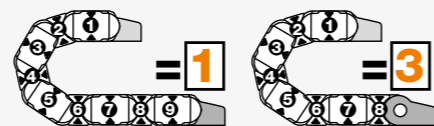

8000.1.12.VS.A2 Order example

- .A...** Please specify fastening variant
- Pre-assembled
- Full set, pivoting
- Odd numbers of links
- Series

Strain relief e.g. clamps, tiwrap plates, nuggets and clips are available from stock. The complete chainfix range with ordering options ▶ From page 1392

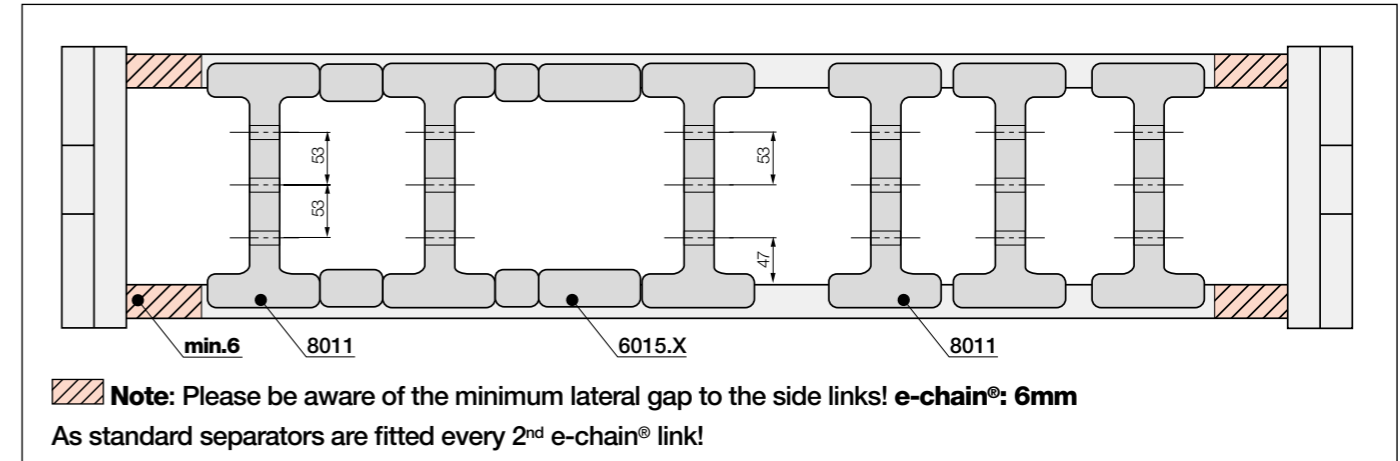

Image	Dimension	Part No.
	10	Slotted separator
		unassembled 8001
		assembled 8011

Slotted separator
For a vertical subdivision. The slot allows basic vertical/horizontal shelving arrangements.

Image	Dimension	Part No.
	XX (mm) = 10, 15, 20	Spacer for e-chains®
		unassembled 6005.XX
		assembled 6015.XX

Spacer
Separators can be fixed in position using spacers. The available interior height is reduced by 2mm per spacer (4mm when spacers are fitted on both sides). To avoid this, the parts can also be installed on the outside of the opening crossbar.

Modular shelving system | Series 800

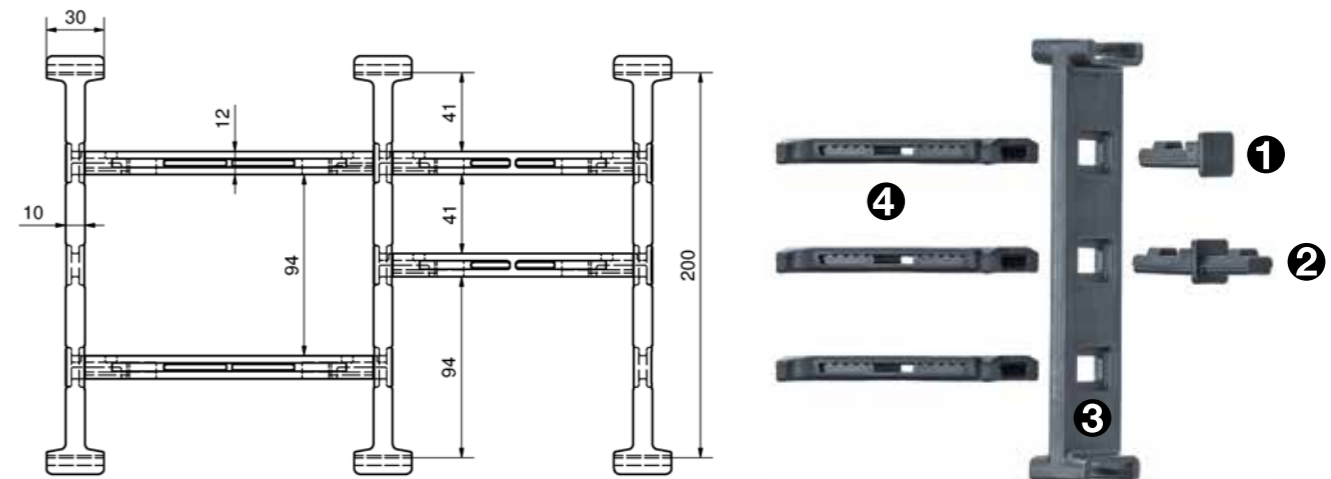

- Secure separation even for large cables
- Easy assembly
- Robust, even for large cable diameters
- Modular
- Widths from 50 to 600mm

Part No. unassembled	Part No. assembled	Design snap in tab	Part No. separator	Part No. crossbar	Width [mm]
8001H1	8011H1	1 one side	8001	450.XX.A	50-600
8001H2	8011H2	2 both sides	8001	450.XX.A	50-600



e-chains® | Series 840 | Crossbars every link (crossbars removable along the inner and outer radius)

Part No. e-chains®	Bi [mm]	Ba [mm]	840 [kg/m]	Part No. e-chains®	Bi [mm]	Ba [mm]	840 [kg/m]
840.13.R.0	100	160	≈ 13.84	840.36.R.0	325	385	≈ 15.09
840.15.R.0	113	173	≈ 13.87	840.37.R.0	338	398	≈ 15.11
840.16.R.0	125	185	≈ 13.95	840.38.R.0	350	410	≈ 15.15
840.17.R.0	138	198	≈ 14.04	840.40.R.0	363	423	≈ 15.34
840.18.R.0	150	210	≈ 14.13	840.41.R.0	375	435	≈ 15.39
840.20.R.0	163	223	≈ 14.17	840.42.R.0	388	448	≈ 15.50
840.21.R.0	175	235	≈ 14.22	840.43.R.0	400	460	≈ 15.57
840.22.R.0	188	248	≈ 14.27	840.45.R.0	413	473	≈ 15.63
840.23.R.0	200	260	≈ 14.35	840.46.R.0	425	485	≈ 15.69
840.25.R.0	213	273	≈ 14.43	840.47.R.0	438	498	≈ 15.72
840.26.R.0	225	285	≈ 14.49	840.48.R.0	450	510	≈ 15.80
840.27.R.0	238	298	≈ 14.57	840.50.R.0	463	523	≈ 15.87
840.28.R.0	250	310	≈ 14.61	840.51.R.0	475	535	≈ 15.91
840.30.R.0	263	323	≈ 14.72	840.52.R.0	488	548	≈ 15.93
840.31.R.0	275	335	≈ 14.75	840.53.R.0	500	560	≈ 16.00
840.32.R.0	288	348	≈ 14.82	840.55.R.0	513	573	≈ 16.31
840.33.R.0	300	360	≈ 14.91	840.60.R.0	563	623	≈ 16.47
840.35.R.0	313	373	≈ 15.06				

Available bend radii

R [mm] | 325 | 350 | 400 | 450 | 500 | 600 | 750 | 1,000 |

Complete Part No. with required radius (R). Example: 840.40.400.0 = crossbars every link

Reduce assembly time - E4 e-chain® opener

- e-chain® opener tools for easy opening and closing of e-chains®
- Simple opening and closing of e-chain® crossbars
- Also for use in hard to reach locations
- Significant assembly time reduction

More information ► www.igus.eu/E4savetime

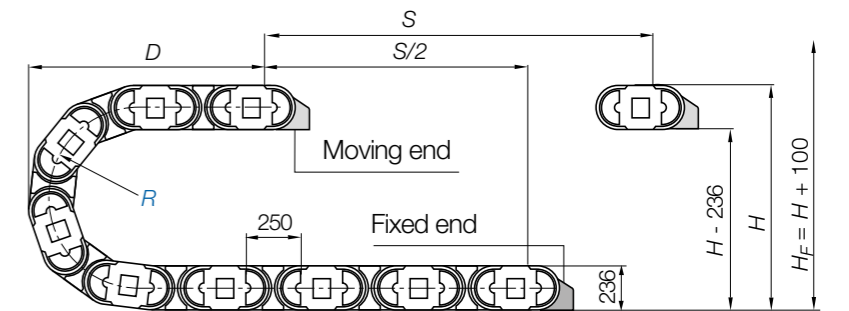
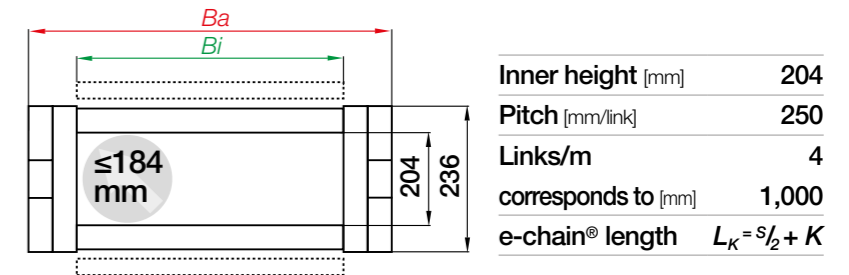
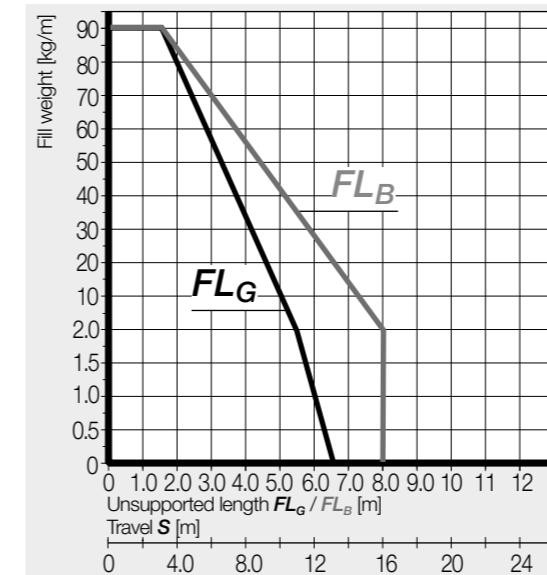

R	325	350	400	450	500	600	750	1,000
$H_{-0.25}^{+25}$	886	936	1,036	1,136	1,236	1,436	1,736	2,236
D	818	843	893	943	993	1,093	1,243	1,493
K	1,525	1,600	1,760	1,915	2,075	2,385	2,860	3,645

The required clearance height: $H_F = H + 100\text{mm}$ (with 5.0kg/m fill weight)

*Radius not available for e-tubes

Gliding applications | For travel lengths from 15m to max. 450m

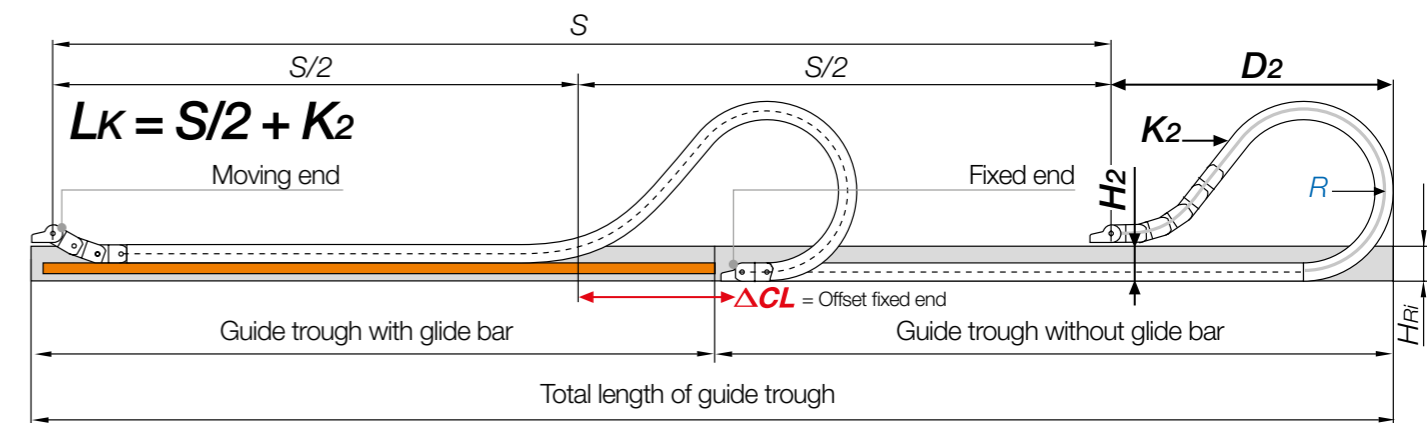

Note: We recommend the project planning of such a system to be carried out by igus®.

In case of travels between 12 and 15m we recommend an e-chain® with a longer unsupported length.

R	325	350	400	450	500	600	750	1,000
H_2	580	580	580	580	580	580	580	580
D_2^{+25}	1,030	1,080	1,380	1,610	2,000	2,480	*	*
K_2	2,000	2,000	2,500	3,000	3,250	4,000	*	*
CL	250	300	550	750	1,050	1,400	*	*

*Values upon request

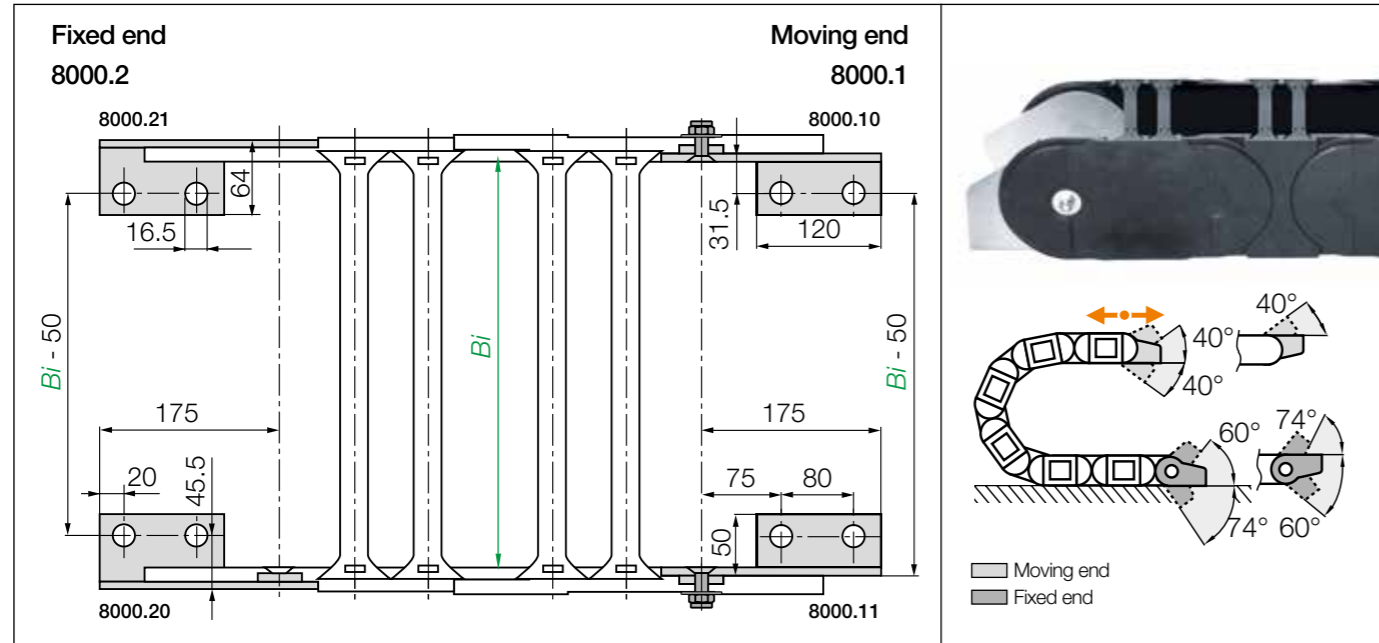

Steel pivoting | For unsupported, gliding, vertical standing and vertical hanging applications

Part No. full set	Description
steel pivoting	Mounting bracket
8000. 1 .12.VS.E45	Full set (both ends) ending with outer side link, screwed - standard
8000. 3 .12.VS.E45	Full set (both ends) beginning with outer side link (moving end) - ending with inner side link (fixed end), screwed - standard

Stainless steel version available. Please add the index **.E45!** (Material: AISI 316Ti stainless steel)

Note: The e-chains® may end with either an inner or an outer side link. An outer side link should always be the first e-chain® link at the moving end. Please specify the index **1** (for odd) or **3** (for even) depending on an even or odd number of links required. For the best appearance, make sure the e-chain® ends with **1** outer side links whenever possible. (with odd number of links)

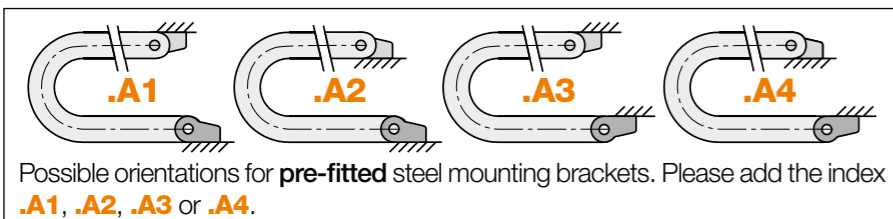
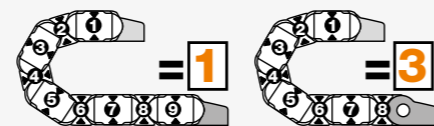

8000.**1**.12.VS.**A2** Order example

- .A...** Please specify fastening variant
- Pre-assembled
- Full set, pivoting
- Odd numbers of links
- Series

Strain relief e.g. clamps, tiwrap plates, nuggets and clips are available from stock. The complete chainfix range with ordering options ► From page 1392

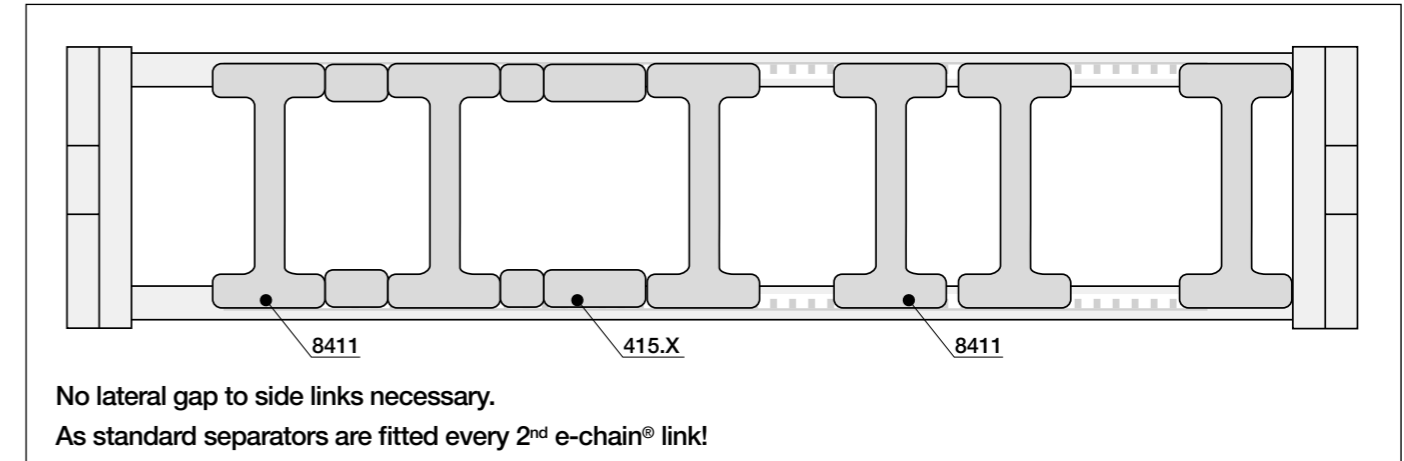

Separator, for e-chains®	
	unassembled 8401
	assembled 8411

Separator
For a vertical subdivision. Offers security due to its wide base design, also when used with large cables or hoses.

Spacer for e-chains®	XX [mm] =	
	10, 15, 20, 30, 40	unassembled 405.XX
		assembled 415.XX

Spacer
Separators can be fixed in position using spacers. The available interior height is reduced by 2mm per spacer (4mm when spacers are fitted on both sides). To avoid this, the parts can also be installed on the outside of the opening crossbar.



... E4.350

e-chains® | Series E4.350 | Crossbars every link (crossbars removable along the inner and outer radius)

Part No.	<i>Bi</i>	<i>Ba</i>	E4.350	Part No.	<i>Bi</i>	<i>Ba</i>	E4.350
e-chains®	[mm]	[mm]	[kg/m]	e-chains®	[mm]	[mm]	[kg/m]
E4.350.400.R.0	400	540	≈ 61.9	E4.350.700.R.0	700	840	≈ 73.4
E4.350.500.R.0	500	640	≈ 65.7	E4.350.800.R.0	800	940	≈ 77.2
E4.350.600.R.0	600	740	≈ 69.6				

Available bend radii

R [mm] | 500 | 750 | 1,000 |

Complete Part No. with required radius (*R*). Example: E4.350.500.500.0 = crossbars every link

i Systems of this type should be designed in conjunction with our engineering team.
Please contact us at ► www.igus.eu/contact

Series E4.350 available as ESD version

- Safe electrostatic discharge through material and design
- Permanently constant discharge due to a positive connection of the e-chain® links to one another

More information ► www.igus.eu/ESD



upon request



upon request

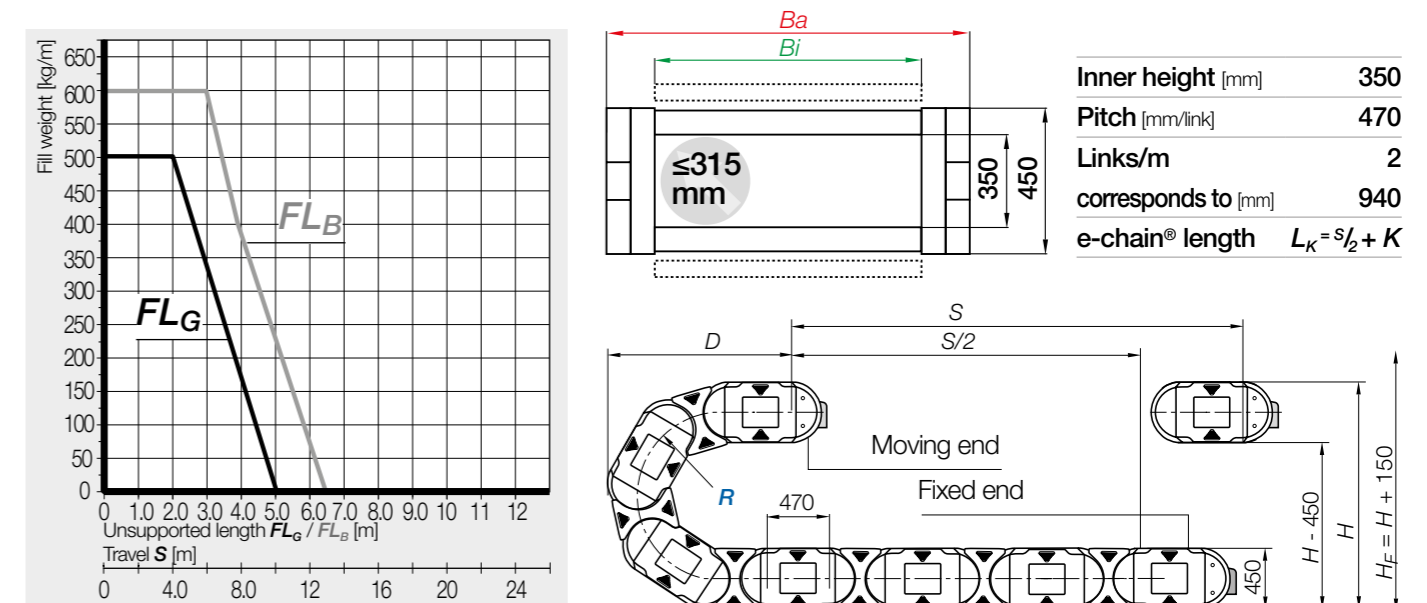

<i>R</i>	500	750	1,000
H_{+25}^0	1,450	1,950	2,450
<i>D</i>	1,430	1,680	1,930
<i>K</i>	2,515	3,300	4,085

The required clearance height: $H_F = H + 150\text{mm}$



The world's largest polymer e-chain® with 350mm inner height: lighter than comparable steel chains, it effortlessly carries more than 100kg of fill weight per metre on a 138m travel

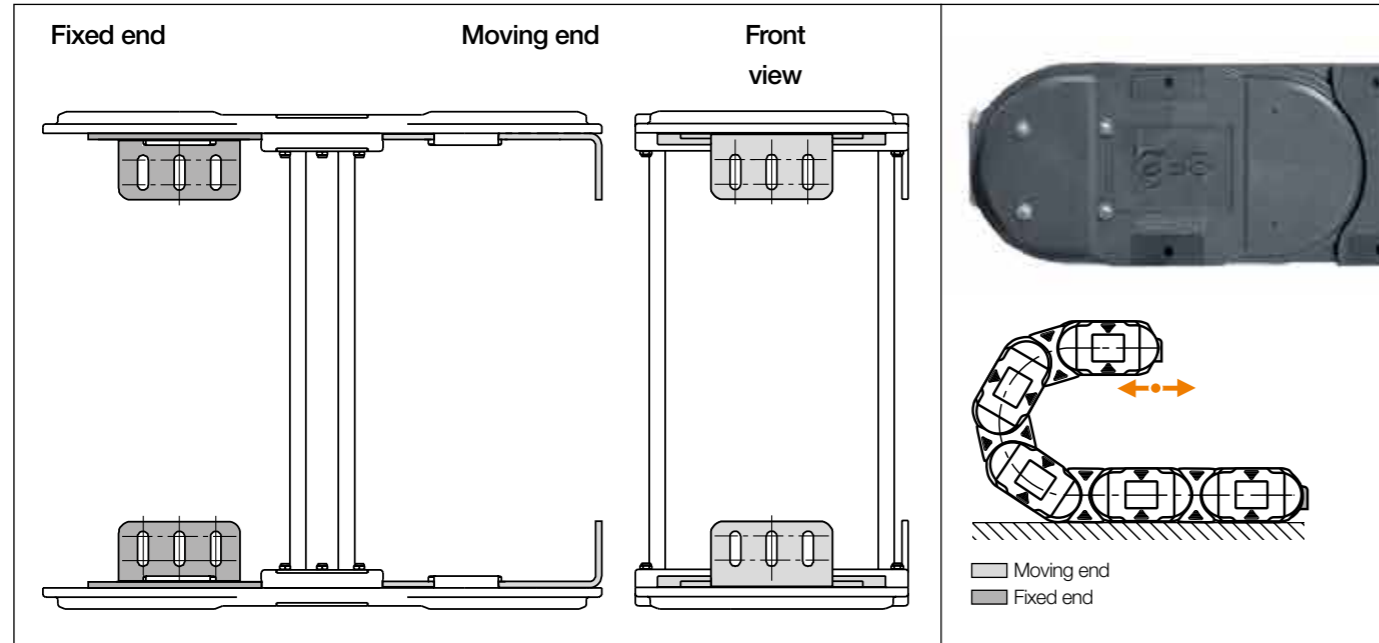

Steel mounting brackets

i Mounting brackets for series E4.350 according to your requirements. Steel or stainless steel available. (Material: AISI 304 stainless steel)



Robust steel mounting bracket for secure fixation and connection

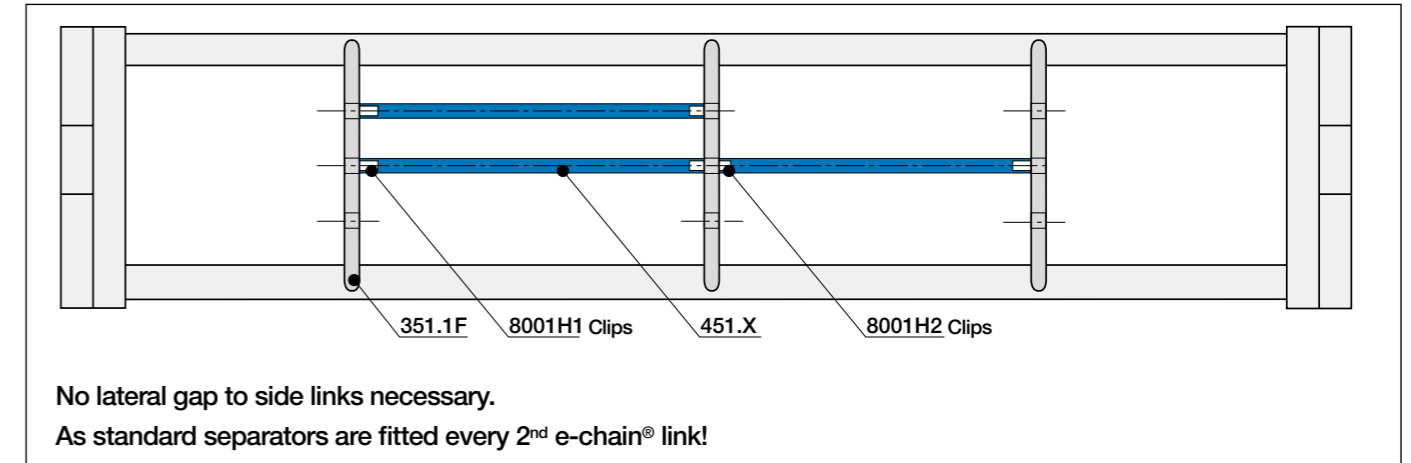

		Separator for vertical subdivision for e-chains®
		unassembled 350.1F
		assembled 351.1F

Separator for vertical subdivision
For a vertical separation with 450.X.

	Horizontal shelves
	unassembled 450.X
	assembled 451.X

Horizontal shelves
For horizontal separation with clips separators for vertical subdivision. Horizontal shelves of various widths can be fitted at 3 different heights.

Horizontal shelves Width = X [mm]	X [mm]			X [mm]			X [mm]		
	unassembled	assembled		unassembled	assembled		unassembled	assembled	
	50	450.050	451.050	225	450.220	451.220	412	450.410	451.410
	55	450.055	451.055	237	450.230	451.230	425	450.420	451.420
	65	450.060	451.060	250	450.250	451.250	437	450.430	451.430
	75	450.070	451.070	262	450.260	451.260	450	450.450	451.450
	87	450.080	451.080	275	450.270	451.270	462	450.460	451.460
	100	450.100	451.100	287	450.280	451.280	475	450.470	451.470
	112	450.110	451.110	300	450.300	451.300	487	450.480	451.480
	125	450.120	451.120	312	450.310	451.310	500	450.500	451.500
	137	450.130	451.130	325	450.320	451.320	512	450.510	451.510
	150	450.150	451.150	337	450.330	451.330	525	450.520	451.520
	162	450.160	451.160	350	450.350	451.350	537	450.530	451.530
	175	450.170	451.170	362	450.360	451.360	550	450.550	451.550
	187	450.180	451.180	375	450.370	451.370	600	450.600	451.600
	200	450.200	451.200	387	450.380	451.380			
	212	450.210	451.210	400	450.400	451.400			



**Undercut
design.**

**Strong
connection.**

E4/light

Large, light and strong



Advantages of the E4/light system:

- Large inner heights combined with low weight
- E4/light e-chains® offer optimum price and performance solutions for many applications
- Especially suitable for short travel distances, hanging and standing designs



When to use another e-chain® series:

- For easy, tool-free opening and closing - the next generation of easy-to-assemble e-chains®
 - ▶ E4Q, page 580
- When the e-chain® needs to be extremely quiet with very low vibration
 - ▶ E6.1, page 832
- When the e-chain® is to be used in cleanrooms
 - ▶ E6.1, page 832
- If large unsupported lengths are required for side-mounted applications
 - ▶ E4.1, page 616
- When longer unsupported lengths and longer travels are required
 - ▶ E4.1, page 616
- When the current standard up to 64mm is preferred
 - ▶ E4.1L, page 538