

# Series MAX3

Compact Magnetic Absolute Linear Encoder



- Absolute measurement for increased safety (resolution 1 mm)
- Ideally suited for mobile automation applications
- Measuring lengths of up to 2450 mm possible
- Insensitive to dust, dirt and water
- Contactless, wear-free measuring principle
- Position detection even in de-energized state
- Only one time definition of the Min and Max position
- No further calibration or referencing required
- Automatic distance detection (LED lights up red if the distance between sensor and magnetic tape is too large)
- Quick and easy installation

# MAX3 - Compact Magnetic Absolute Linear Encoder with Distance Detection

## General:

MAX3 is a magnetic absolute length measuring system designed for measuring lengths up to 2450 mm. Thanks to its compact design, the non-contact and wear-free measuring principle as well as its high IP65 protection class (optionally IP69K), the measuring system is particularly suitable for use in harsh environments (e. g. mobile automation).



The sensors and the necessary evaluation electronics are integrated in a compact metal housing, which converts the scanned signals into the desired interface format. By using the supplied adhesive tape, the absolutely coded magnetic tape is glued onto a flat surface. The maximum allowed mounting distance between sensor and magnetic tape is 1.0 mm. Further tolerances can be found on the last page.

## Advantages:

A major advantage of the MAX3 is its compact design, which makes it equally suitable for retrofitting as well as new installations in existing machines and vehicles.

Due to the absolute measuring principle, no further referencing is required after the minimum and maximum positions have been defined once.

## The absolute Measuring Principle:

The absolute measuring principle ensures maximum safety, as the current position value is always present. Even in the event of a power failure, no data is lost.

## The functional Principle:

A Hall sensor line is guided over a coded magnetic tape which is written with an absolute track and always provides the current absolute position. The sensor system scans the code sequence of the north and south poles and determines the absolute value with a resolution of 1 mm. Usable magnetic tapes are the 10 mm wide variant AB20-21-10-1-R-D-10 or the 20 mm wide AB20-21-20-1-R-D-10.



This absolute measured value is processed by the internal evaluation electronics and is available either via a CANopen interface or as an analog output signal (mA or V). From here it can be further processed by the subsequent electronics.

## Available Output Interfaces:

- Interface option I20 → Analog 12 bit output signal (0 ... 20 mA), proportional to the measured value
- Interface option I24 → Analog 12 bit output signal (4 ... 20 mA), proportional to the measured value
- Interface option V04 → Analog 12 bit output signal (0.5 ... 4.5 V), proportional to the measured value
- Interface option V10 → Analog 12 bit output signal (0 ... 10 V), proportional to the measured value
- Interface option CA0 → CANopen standard interface according to DS406 (encoder profile)

## Installation / Alignment:

10 mm wide tape:

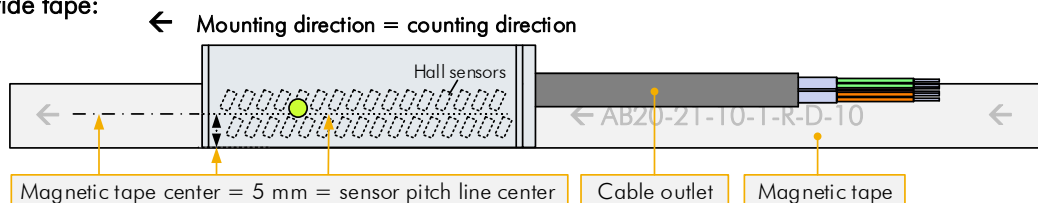

20 mm wide tape:

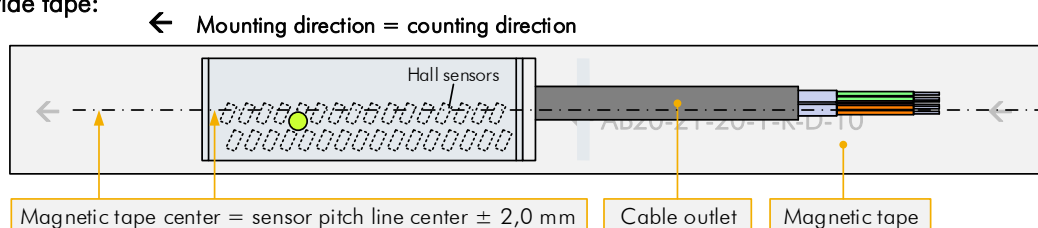

# MAX3 - Compact Magnetic Absolute Linear Encoder with Distance Detection

## Technical Data:

Mechanical data	
Measuring principle	absolut
Repeat accuracy	±1 increment
System accuracy	±1 mm at max. 2450 mm measuring length (standard)
Distance sensor - tape	max. 1.0 mm
Measuring length	max. 2450 mm
Housing material	galvanized aluminium
Dimensions	L x W x H = 52 x 16 x 30 mm
Magnetic tape types	AB20-21-10-1-R-D-10 (10 mm) or AB20-21-20-1-R-D-10 (20 mm)
Basic pole pitch	2,1 mm
Sensor cable length	standard: 1.5 m (others on request)
Weight (without cable)	approx. 50 g; cable approx. 60 g/m
Electrical data	
Power supply voltage	10 ... 30 VDC
Residual ripple	10 ... 30 VDC < 10 %
Current consumption	max. 80 mA
Available interfaces	CANopen standard (DS406) 12 bit analog output (0 ... 20 mA) 12 bit analog output (4 ... 20 mA) 12 bit analog output (0.5 ... 4.5 V) 12 bit analog output (0 ... 10 V) SSI (binary or Gray) on request
Connections	standard: open cable ends optionally: 5-pin M12 round connector (other connectors on request)
Resolution	1 mm
Operating speed	max. 2.0 m/s
Environmental conditions	
Storage temperature	-25 ... +85° C
Operating temperature	-25 ... +85° C
Humidity	max. 95 %, non-condensing
Protection class	standard: IP40 / optionally: IP65

## Connections (Standard):

Open cable ends:

Color	CAN	ANALOG
black	0 V / GND	0 V / GND
brown	+VCC	+VCC
red	-	TEACH 1
orange	-	-
green	CAN HIGH	Analog OUT
yellow	CAN LOW	Analog GND
blank	Screen/shield	-

## Type Designation:

MAX3  
A A B B C C C C D D D D F F F F G H I J

### A Version

00 = ELGO standard version  
01 = first special version (etc.)

### B Signal Cable Length (in dm)

015 = 15 dm (±1.5 m) standard length  
(others on request)

### C Resolution (in µm)

1000 = 1000 µm (± 1 mm)

### D Interface

I20 = 12 bit analog output (0 ... 20 mA)  
I24 = 12 bit analog output (4 ... 20 mA)  
V04 = 12 bit analog output (0.5 ... 4.5 V)  
V10 = 12 bit analog output (0 ... 10 V)  
CA0 = CANopen interface (DS406 encoder profile)  
SBO = SSI interface, 25 bit binary code (on request)  
SG0 = SSI interface, 25 bit Gray code (on request)

### F Bit Rate (only for CANopen interface)

125k = 125000 bit/s  
250k = 250000 bit/s  
500k = 500000 bit/s  
1MHz = 1000000 bit/s

## Additional Options

**G Address** = CAN device address 0 ... F (standard = 0)

### H Connections

---- = open cable ends (standard)  
R5M0 = 5-pin (male) M12 round connector

**I A** = CANopen without internal termination resistor

**J V** = IP65

Order example:

MAX3000151000CA0250kFR5M0A-  
A A B B C C C C D D D D F F F F G H H H H I J

ELGO standard MAX3 with 1.5 m long cable, 1 mm resolution, CAN interface with 250 kB bit rate and device address F, connections via 5-pin M12 round connector, CAN without termination resistor

## Connections (Option R5M0):

5-pin M12 round connector:

Pin	CAN	ANALOG
1	Screen/shield	TEACH
2	+VCC	+VCC
3	0 V / GND	0 V / GND
4	CAN HIGH	Analog OUT
5	CAN LOW	Analog GND
Housing	-	Screen/shield

## MAX3

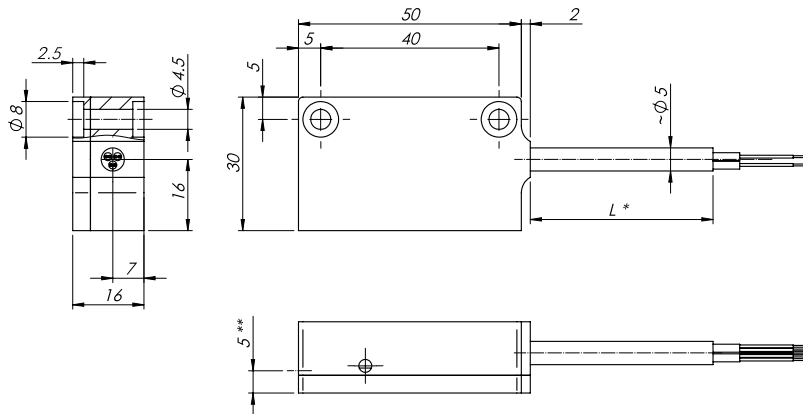

- \*) cable length  
 \*\*) sensor pitch line center = center of magnetic tape

### Mounting Tolerances:

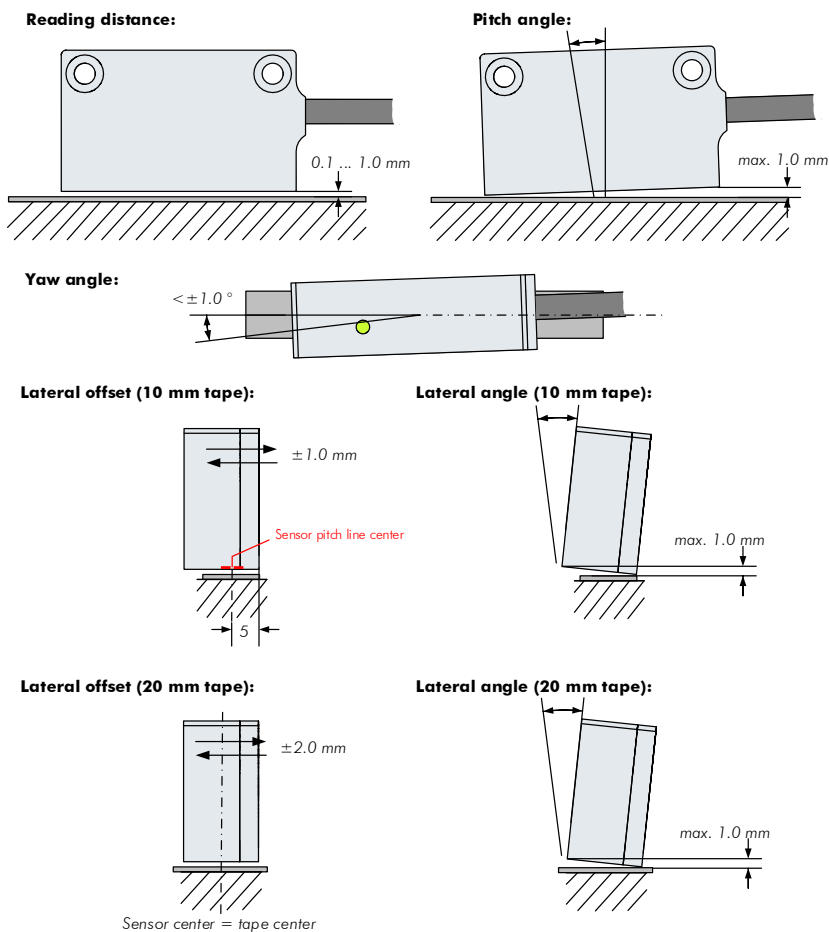

### MAX3 Accessories:

Order Designation	Description
AB20-21-10-1-R-D-10	10 mm wide magnetic tape for MAX3 (max. measuring length = 2450 mm). Order length = measuring length + 52 mm (sensor length) + 50 mm (end caps)
AB20-21-20-1-R-D-10	see line above, but 20 mm wide magnetic tape
End cap set 10 mm	2 end caps (10 mm) and 2 x M3 screw; for additional fixation of the magnetic tape, as well as for the protection of the magnetic tape ends.
End cap set 20 mm	see line above, but for 20 mm wide tapes
FS-1000, FS1500 or FS2000	Guide rail, suitable for 10 and 20 mm wide magnetic tape. Available lengths: 1.0 m, 1.5 m and max. 2.0 m. The rails can be lined up for higher measuring lengths.
710000130	PSF 30 x 30 mm pole finder foil for magnetic tapes

