

► **Dynamic drier**



- ▶ Aluminium body
- ▶ Wall mounting possibility with M8 screws
- ▶ Filtering cartridge made of HDPE available in three different filtration grades (5µm, 20µm, 50µm)
- ▶ Filter cartridge can be regenerated by washing / blowing it or replaced
- ▶ With blind metal bowl
- ▶ Bowl assembly via bayonet type quick coupling mechanism with safety button
- ▶ Automatic condensation drain

2
AIR TREATMENT

Technical characteristics	Size
	Size 4
Body and connections type	Aluminium body with integrated aluminium connections
Protection and bowl type	Metal bowl with blind metal bowl
IN / OUT connections	G1"
Assembly configuration	Stand alone Panel mounted with M8 screws
Assembly position	Vertical ±5°
Filter pore size (µm)	5 / 20 / 50
Filter efficiency at flow rate 1500 NI/min	96,00%
Bowl capacity (cm³)	160
Condensation drain	Automatic
Max. fittings torque IN / OUT connections	G1"metal: 35

Operational characteristics	Size
	Size 4
	Automatic condensation drain
Maximum working pressure (bar)	13
Minimum working pressure (bar)	0,5
Nominal flow rate at 6 bar with Δp=1 (NI/min)	2500
Working temperature (°C)	-5 ÷ +50

Weights	Size
	Size 4
Aluminium body version (g)	1700

Order codes

17 40EB . A . S

Size, body and connections

40EB : Aluminium body, connections G1" (only for size 4)

Filter pore size

A : 5 µm

B : 20 µm

C : 50 µm

Example: 1740EB.A.S

Dynamic direr Size 4, aluminium body, G1" connections, filter pore size 5 µm

Dimensions

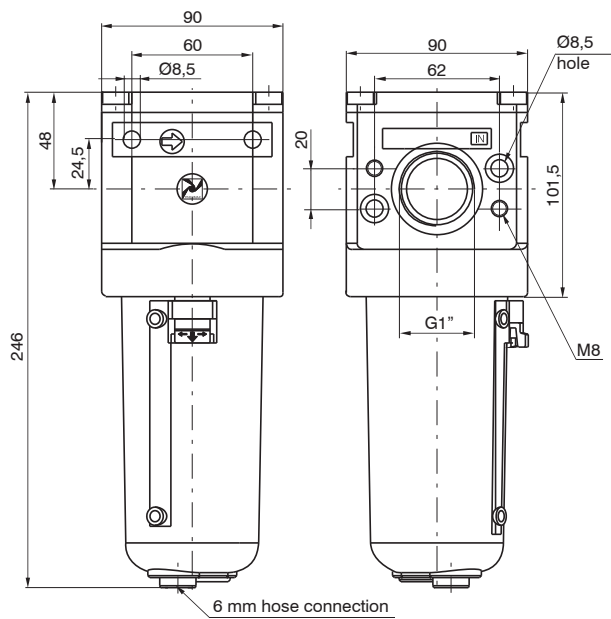

Size 4